

Design of driver cards with SCALE drivers

Notes for implementing IGBT driver cards

Introduction

It really is quite easy to implement a driver card for controlling IGBTs with a SCALE driver. Especially if you observe these notes that have proved their worth in practice. They are designed to answer the questions most frequently asked by users.

Contents

Protecting the inputs	2
Locking the inputs without dead-time generation	3
Voltage monitoring & power-up reset	4
Automatic error reset	6
Power supply	8
Hints on the application notes	9

Application Note

Protecting the inputs

A driver card is as a rule connected to the control electronics via a cable of variable length. The inputs of the SCALE driver should therefore be suitably protected. Protection against transients is also stipulated by the relevant standards (e.g. CE standards).

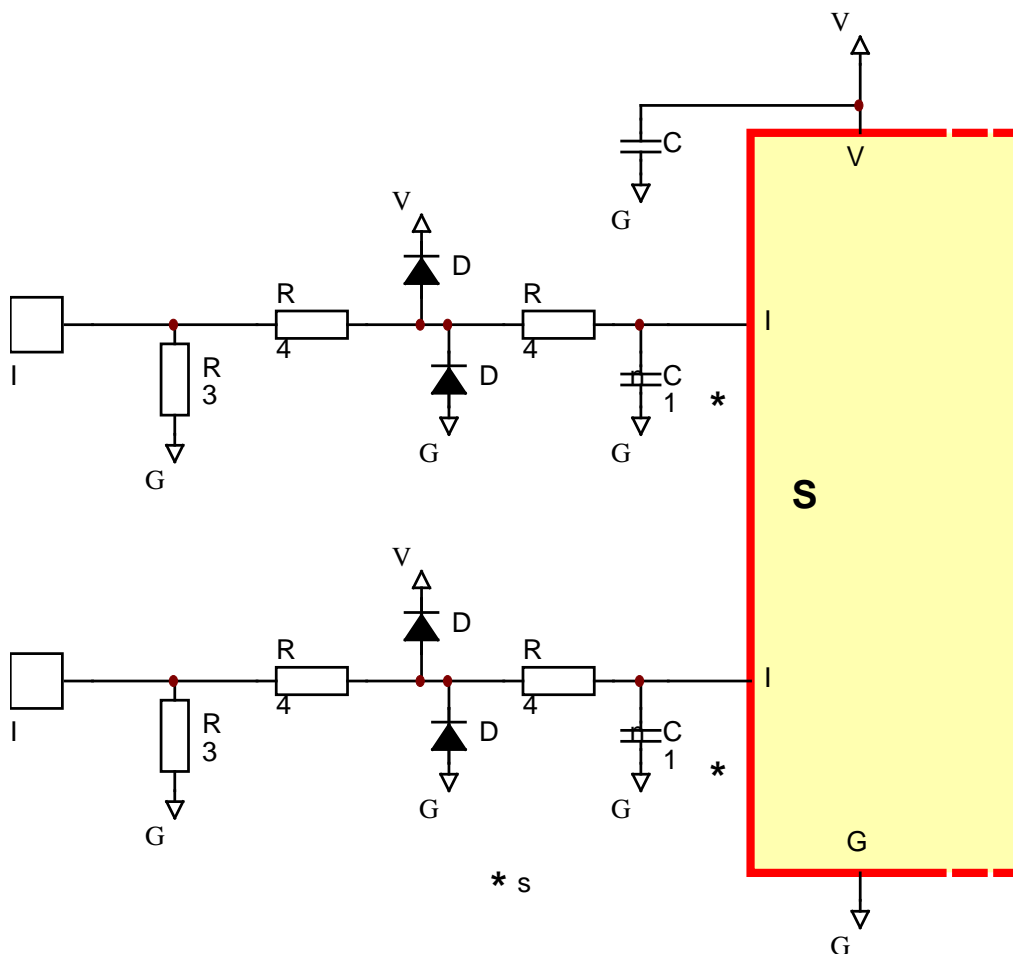

Fig. 1 Wiring and protection of the inputs

Figure 1 shows a protection circuit for the inputs. Schottky diodes should be used for this purpose. The R_{x1} s pull the inputs to GND if the connectors are unplugged or the input-signal drivers are high-resistance. The C_{x1} s are optional if suppression of short pulses or unwanted spikes is required at the inputs. The specified component values produce a signal delay of approximately $1\mu\text{s}$.

When driver cards are controlled via cable connections, we recommend – due to the greater signal-to-noise ratios – that a 15V level be used throughout in place of 5V levels.

Application Note

The connecting cables to the driver card must never be connected or disconnected when carrying current.

Note: The protection wiring shown in Fig. 1 is naturally not required if the driver is located on the same circuit board as the pre-connected control or regulation electronics.

Locking the inputs without dead-time generation

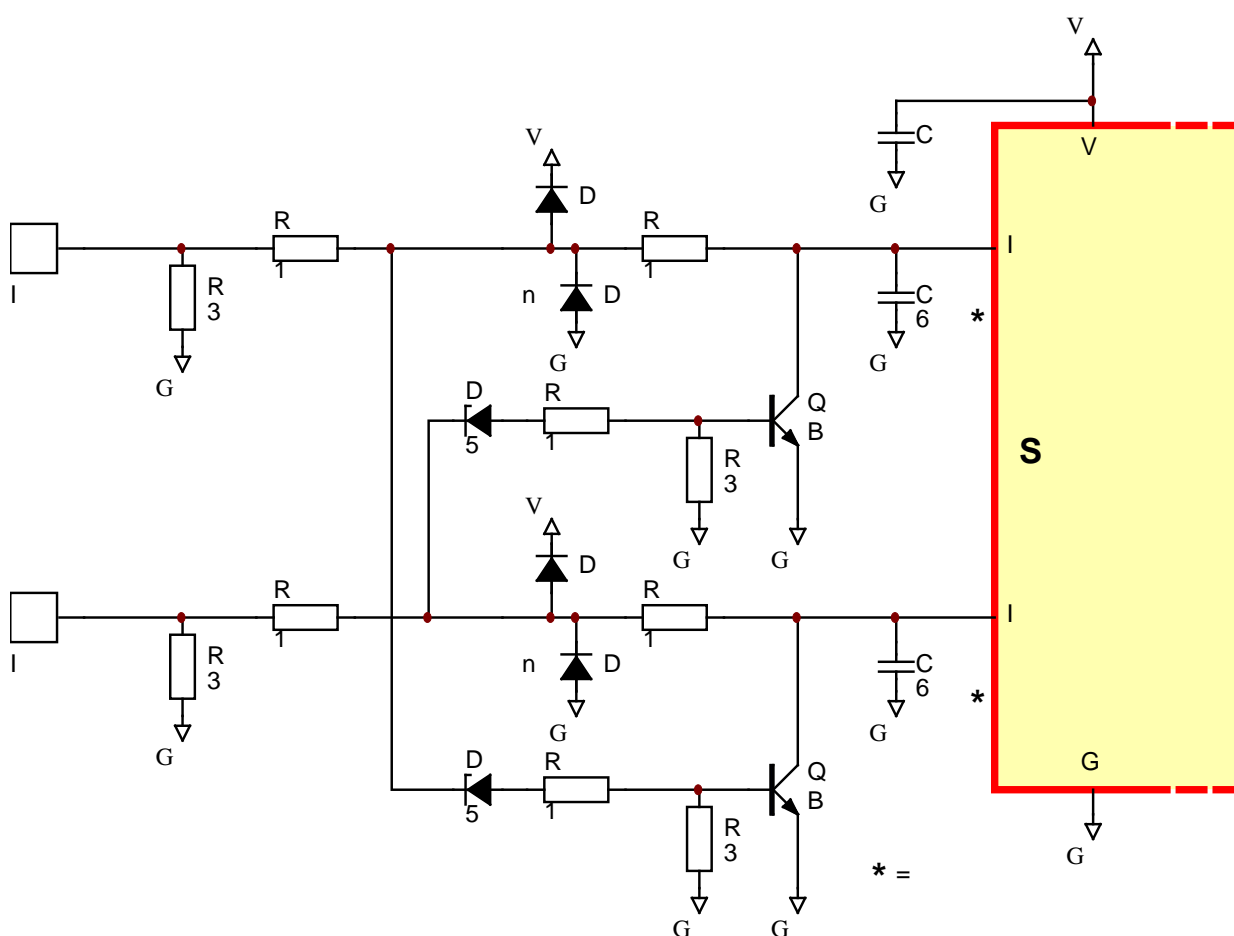

Fig. 2 Wiring, protection and locking of the inputs

Users often try to lock signals with respect to each other in direct mode so that short-circuit of the IGBTs is excluded under any circumstances, even if an “on signal” is (incorrectly) present at both inputs of a half-bridge.

The circuit shown in Fig. 2 corresponds to that in Fig. 1, but it has been extended by a locking function. When both inputs are on “Hi”, both IGBTs are locked.

Application Note

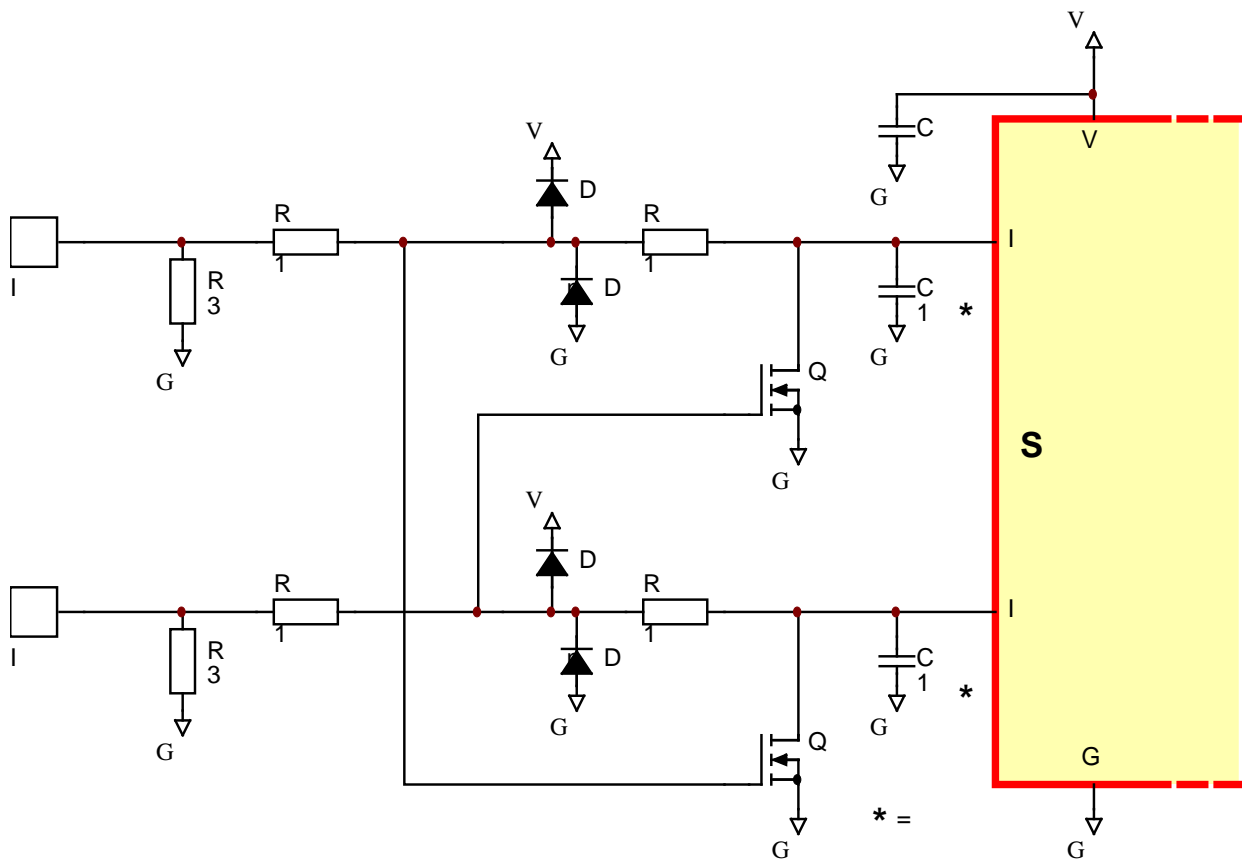

Fig. 3 Variant of locking the inputs with FETs

The circuit shown in Fig. 3 has the same function as that in Fig. 2 but has become simpler by the use of FETs.

Voltage monitoring & power-up reset

After the supply voltage has been applied, error information is always stored in the error memories of the SCALE drivers.

Application Note

If the SCALE driver is used directly on a card together with a (processor) controller, resetting of the error memory may be triggered by the power-up reset circuit which is usually present in any case.

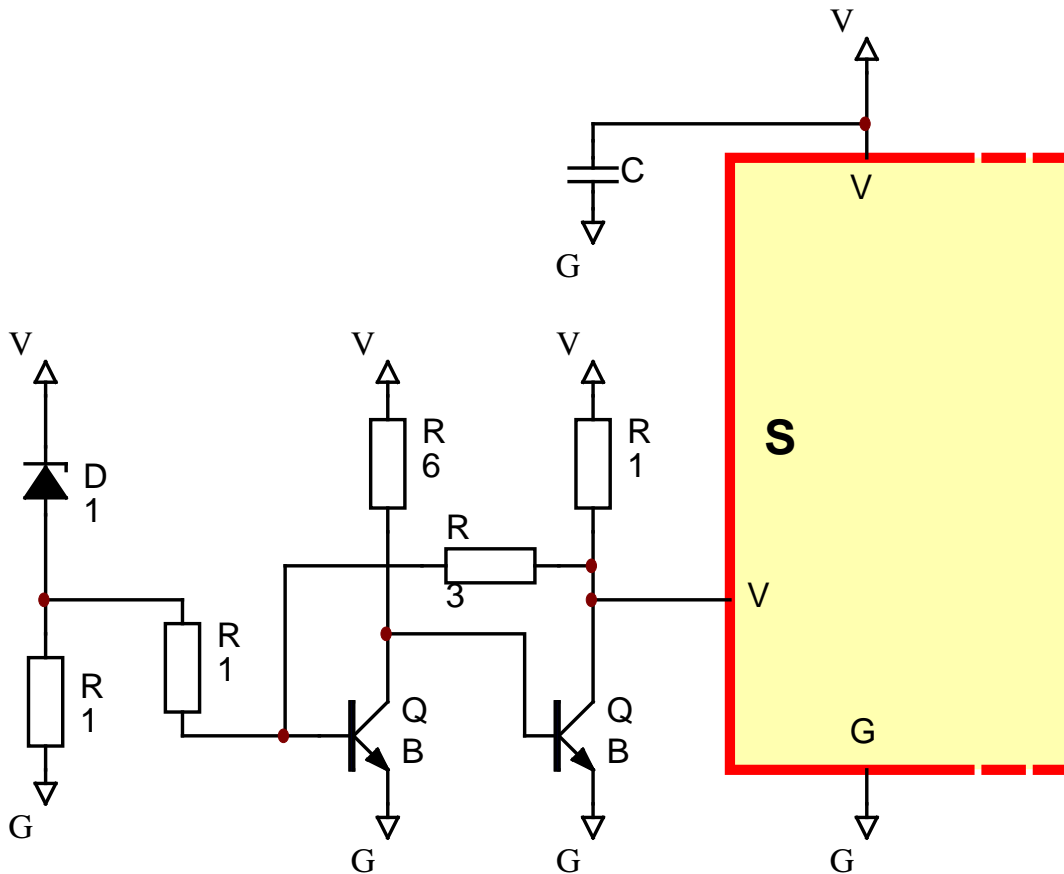

Fig. 4 Voltage monitoring and power-up reset

The circuit shown in Fig. 4 is recommended where no power-up reset is available as well as for use on driver cards. It consists of two discrete components. The characteristics of the circuit are: turn-on at approx. 12.7V; turn-off at approx. 12V.

Application Note

Automatic error reset

As soon as a driver channel has responded, the status is stored in the relevant error memory of the SCALE driver. Some applications require a solution in which an error is followed by the emission of an error signal of specific duration which then disappears automatically (like the error acknowledgement for the drivers of the IHD series from CONCEPT).

Figure 5 shows a variant circuit which satisfies this function.

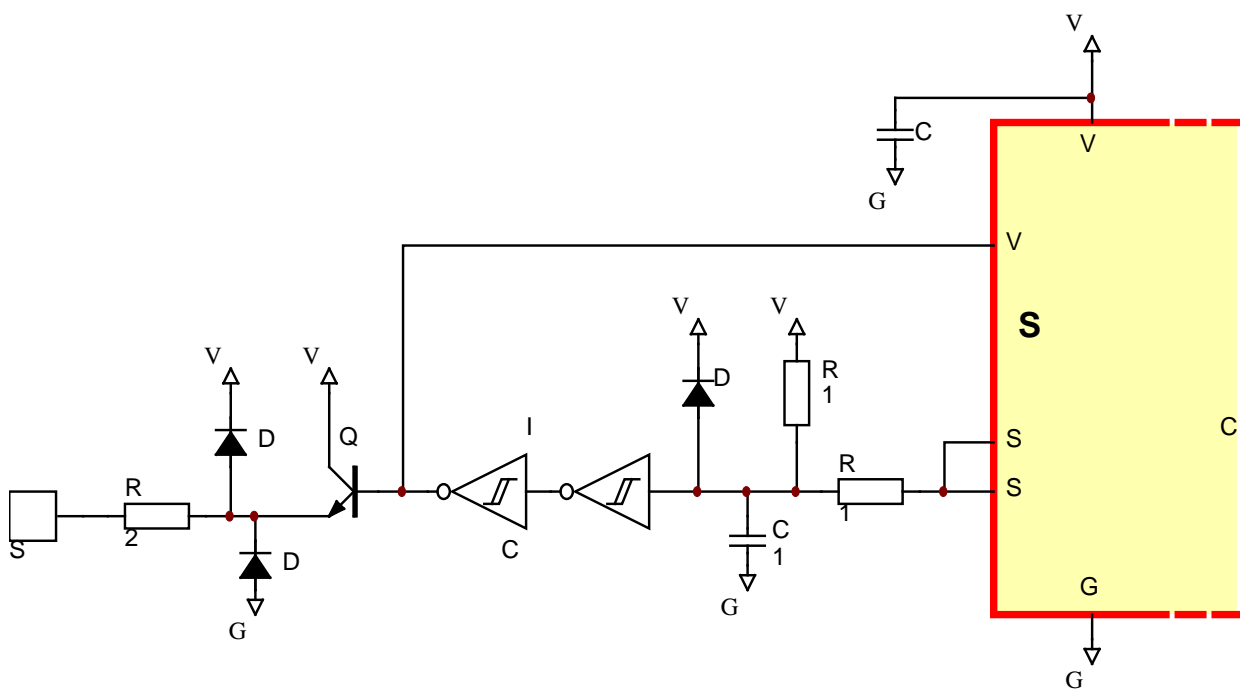

Fig. 5 Automatic error reset and status output

The circuit has the following characteristics: in "normal status", the "StatusOut" output is at +15V. In the case of an error, the output transistor Q1 turns off for about 10 μ s. The components D1, D2 and R3 are designed to protect the output transistor Q1. D3 should be a Schottky diode.

Voltage monitoring & automatic error reset

The circuit in Fig. 6 combines the functions of the two preceding sections. It thus contains an under-voltage monitoring circuit and automatic reset of the error memory after an error.

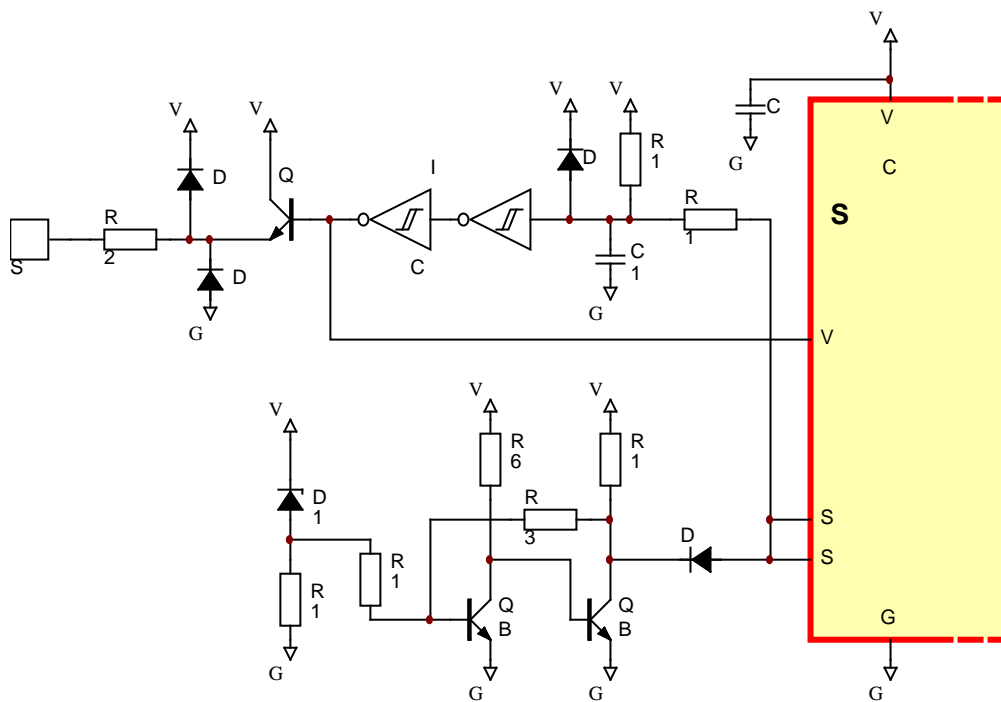

Fig. 6 Monitoring of the supply voltage and automatic reset

Application Note

Power supply

Under certain circumstances, the DC/DC converters contained in the SCALE drivers may cause a short circuit in the voltage supply line if the drivers are short-circuited on the output side (e.g. in the event of destruction/short circuit of the IGBTs).

A power supply unit is therefore recommended with a current-limiting function or fuse (incl. a multi-fuse) in the VDC line so that the circuit board is not damaged in the event of a defect. It may be useful to add an inverse-polarity protection circuit to a driver card and an over-voltage protection circuit (transient suppressor D1 in Fig. 7) on the voltage supply side.

The voltage supply should be suitably blocked with capacitors (electrolytic capacitors with minimum ratings as shown on the driver data sheet). The feed line should be low inductance to avoid oscillations in the supply voltage.

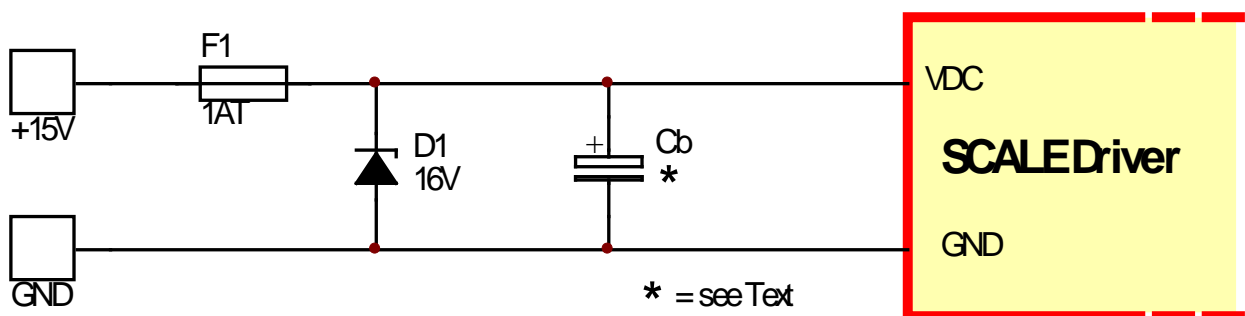

Fig. 7 Protection of the voltage supply

Hints on the application notes

All application information's as well as this documentation are designed as starting aids to allow the user to develop his own final power stages. CONCEPT cannot guarantee the observation of the relevant standards and specifications, nor reproducibility and long-term characteristics of the application examples. These are the sole responsibility of the user.

Neither can CT-Concept Technologie AG guarantee that the circuit documents, descriptions, calculations, procedures or technical information published herein are unencumbered by any claims from third parties regarding patents, approval obligations or industrial property rights. These documents are designed exclusively for the purposes of study and teaching as well as to provide basic information for the user's own development projects. If the user wishes to use this documentation for commercial or similar purposes, it is recommended that he clarifies the relevant patent situation and takes steps to obtain any necessary licenses. CONCEPT is unable to provide any information on these points. If the user plans to manufacture this equipment on a series scale, he should obtain exact component specifications with their possible applications directly from the manufacturer as well as carry out his own series of measurements to safeguard his procedures.

When working with experimental set-ups that affect parts of VDE, UL or other applicable safety specifications, the user should consult the documentation on the relevant safety and security regulations beforehand and subsequently observe these in practice.

Contact Address

CT-Concept Technologie AG
Intelligent Power Electronics
Renferstrasse 15
CH-2504 Biel-Bienne
Switzerland

Tel. +41 - 32 - 344 47 47
Fax +41 - 32 - 344 47 40

E-mail Info@IGBT-Driver.com
Internet www.IGBT-Driver.com