

Description and Application Manual

for 2SB315B SCALE Dual-Channel Plug-and-play IGBT Drivers

Driver solution for 130mm x 140mm dual IGBT modules with fiber-optic interface for 2-level topologies

Abstract

The 2SB315B is a dual-channel driver based on CONCEPT's 2SD315AI SCALE driver core, a proven technology for the reliable driving and safe operation of IGBTs.

The driver is matched to several dual IGBT modules with dimensions of 130mm x 140mm. Its plug-and-play capability makes it ready to operate immediately after mounting. The user needs invest no effort in designing or adjusting it to a specific application.

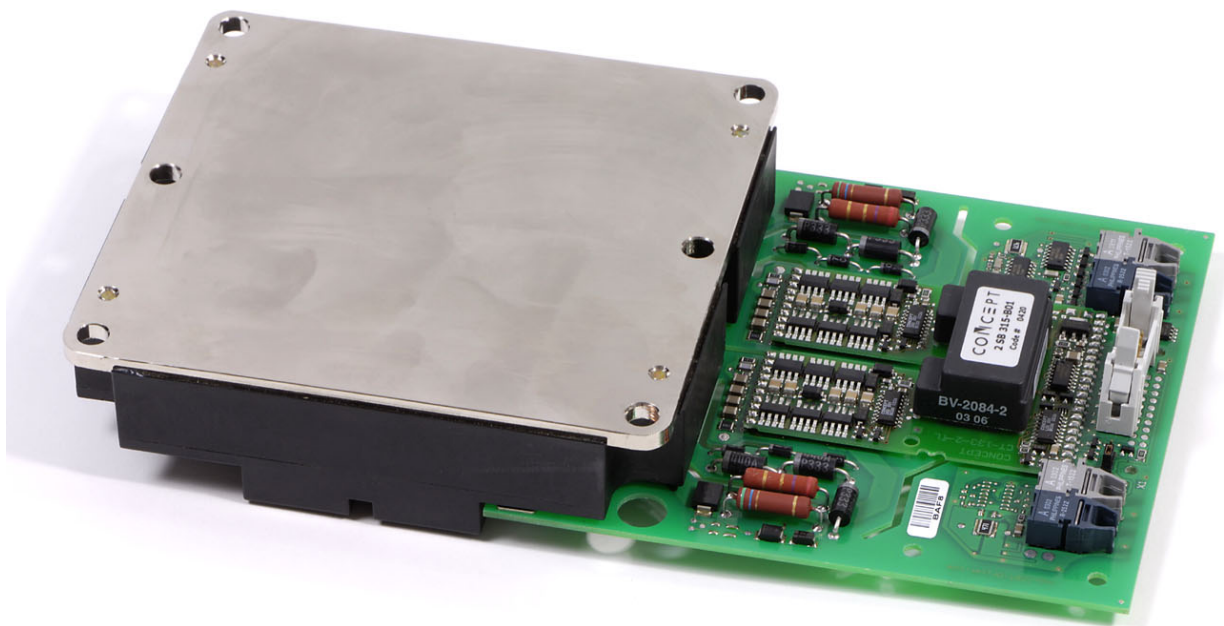

Fig. 1a 2SB315B screwed onto a 130mmx140mm IGBT module (bottom view)

Description and Application Manual

Contents

System Overview	4
The Six Steps to Success.....	5
1. Choose a suitable driver	5
2. Attach the drivers to the IGBT modules.....	5
3. Connect the driver to the control electronics	5
4. Select the operating mode	5
5. Check the driver function	6
6. Set up and test the power stack	6
Pin Designation of Connector X2	7
Description of Interface X2.....	7
General.....	7
VDC terminal.....	7
VDD terminal	7
Description of Jumper J1 (mode selection)	8
Description of Fiber-Optic Inputs	9
Description of Fiber-Optic Outputs (status feedback & edge acknowledge)...	9
Recommended Interface Circuitry for Fiber Optics	11
Protection Concept	12
Power-supply monitoring	12
Short-circuit and overcurrent protection.....	12
Active clamping	13
Bibliography	14
The Information Source: SCALE Driver Data Sheets.....	15
Quite Special: Customized SCALE Drivers.....	15
Evaluation Systems.....	15
Customer-Specific Systems	15
Consulting and Training.....	16

Description and Application Manual

Technical Support 16

Quality 16

Disclaimer 16

Ordering Information 17

Information about Other Products 17

Manufacturer 17

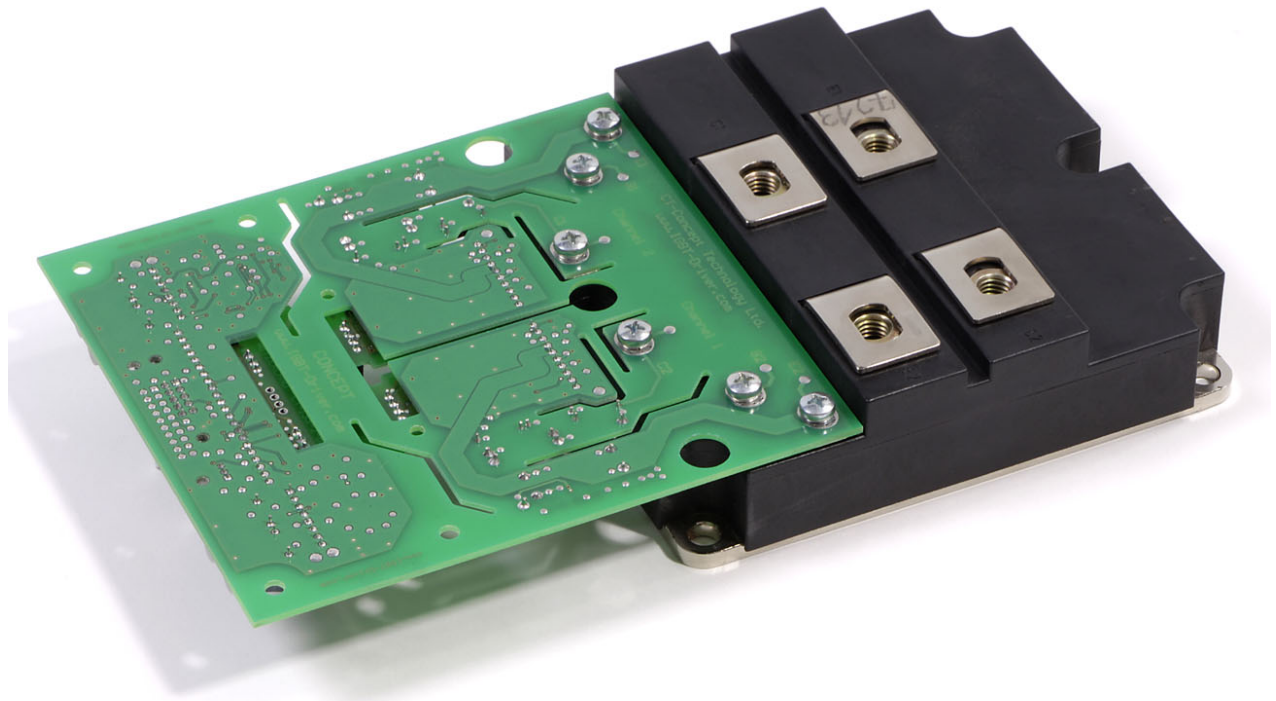

Fig. 1b 2SB315B screwed onto a 130mmx140mm IGBT module (top view)

Description and Application Manual

System Overview

The 2SB315B comprises the standard driver 2SD315AI (see /3/ for more details) mounted on a basic board. It is based on the proven SCALE technology developed by CONCEPT and implemented more than a hundred thousand times. For further information on this technology, refer to /1/, /2/ and /3/.

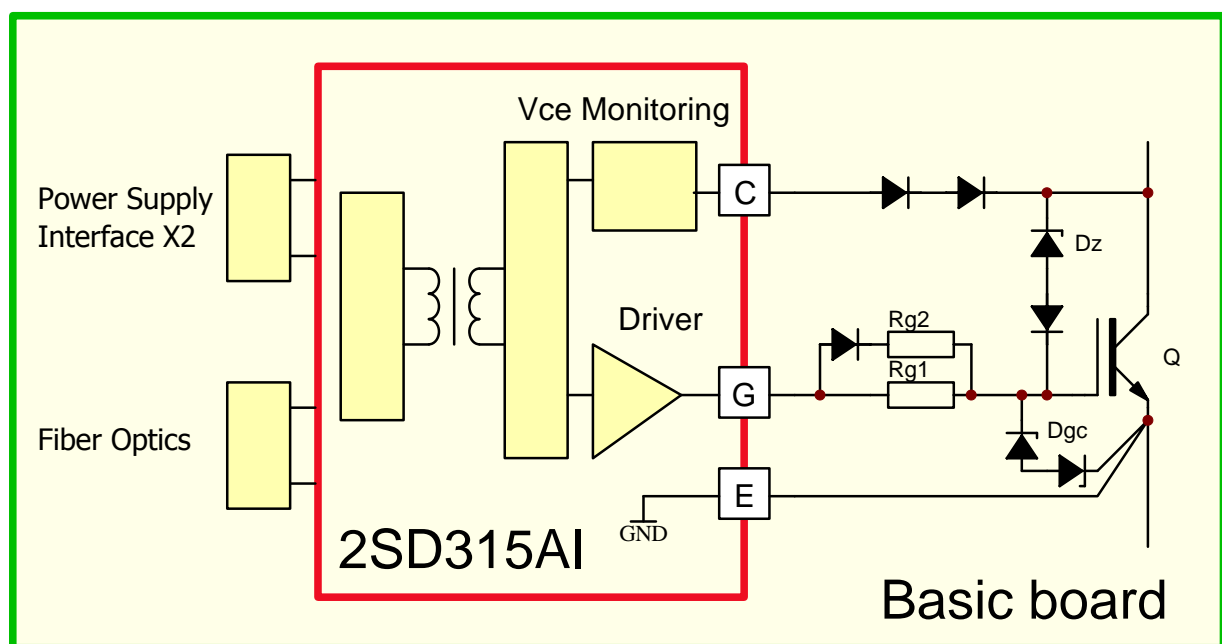

Fig. 2 Separation of universal (red) and IGBT-specific functions (green)

The basic board contains all gate resistors, gate-clamping and active-clamping diodes (overvoltage protection), the diodes for the collector-sense function (surge-current and short-circuit protection) as well as the electrical and fiber-optic connectors. Moreover, it includes components for setting the turn-off trip level, the response time and the dead time between both channels in half-bridge mode. Its plug-and-play capability means that it is ready to operate immediately after mounting. The user needs invest no effort in designing or adjusting the driver to a specific application.

The driver parameters that must be specifically matched to the IGBT module are placed on the basic board, which is completely assembled and tested by CONCEPT. The basic boards are assembled with the smallest possible gate resistor in order to minimize switching losses. The values for the gate resistors and other key components can be found in the specific datasheets for a given IGBT module.

The Six Steps to Success

The following steps point out the easy way to use 2SB315B drivers in power converters:

1. Choose a suitable driver

When applying 2SB315B drivers, you should note that they are specifically adapted to a particular type of IGBT module.

The type designation of the driver consequently also includes a number corresponding to a specific IGBT module (see "Ordering Information").

These drivers are not valid for IGBT modules other than those specified. Incorrect use may result in failure.

2. Attach the drivers to the IGBT modules



Any handling of IGBT modules or drivers is subject to the general specifications for protecting electrostatic-sensitive devices according to international standard IEC 747-1, Chapter IX or European standard EN 100015 (i.e. the workplace, tools, etc. must comply with these standards).

If these specifications are ignored, both IGBTs and drivers may be damaged.

The driver can be easily mounted onto an IGBT module by screwing the corresponding terminals.

3. Connect the driver to the control electronics

Connect the driver plug X2 to your control electronics and supply the driver with a voltage of +15V. Connect the fiber-optic transmitters and receivers.

4. Select the operating mode

The operating mode can be set with jumper J1. For details, see page 8.

Description and Application Manual

5. Check the driver function

Check the gate voltage: For the off-state, the nominal gate voltage is -15V . For the on-state, it is $+15\text{V}$. Also check the input current consumption of the driver without clock signals and at the desired switching frequency.

It is recommended that these tests be performed before installation, as the gate terminals may otherwise not be accessible.

6. Set up and test the power stack

Before starting up the system, it is recommended that each IGBT module be checked separately under power-cycling conditions. It is usually sufficient to apply the single or double-pulse technique.

Even if only single IGBTs are tested, all the system's gate drivers must be supplied with energy. All the other IGBTs can then be kept in the off state by applying negative gate voltages. This is particularly important when switching the IGBTs under test.

The short-circuit behavior can also be verified at this point.

The system is then ready to start under real-world load conditions. This allows the thermal behavior of the whole arrangement to be determined.

The system must be re-qualified over the entire specified range of temperature and load conditions.



CAUTION: All handling with high voltages involves risk to life.

It is imperative to comply with the respective safety regulations!

Description and Application Manual

Pin Designation of Connector X2

Pin	Des.	Function	Pin	Des.	Function
1	VDC	+15V for DC/DC converter	2	GND	Ground
3	VDC	+15V for DC/DC converter	4	GND	Ground
5	VDD	+15V for electronic input side	6	GND	Ground
7	VDD	+15V for electronic input side	8	GND	Ground
9	N.C.	Not Connected	10	N.C.	Not Connected

Description of Interface X2

General

The driver is equipped with a 10-pin interface connector. The even-numbered pins 2, 4, 6 and 8 are used as GND connections. The odd-numbered pins 1, 3, 5 and 7 are used for +15V voltage supply.

VDC terminal

The driver has two *VDC* terminals on the interface connector to supply the DC-DC converters for the secondary sides.

As the driver delivers a total power of $2 \times 3W = 6W$, the maximum input current drawn from the +15V supply is approx. 0.5A (total for terminals *VDC* and *VDD*).

VDD terminal

The driver has two *VDD* terminals on the interface connector to supply the input side of the electronics.

The *VDD* and *VDC* terminals can be connected to a single +15V power supply. A terminal is split into separate pins only for testing.

Description and Application Manual

Description of Jumper J1 (mode selection)

The Jumper J1 located on the primary side near to the connector X2 allows the operating mode to be selected. In position 1, direct mode is selected and in position 3 half-bridge mode is selected.

Half-bridge mode

In this mode, the fiber-optic inputs InA (channel 1/IGBT 2) and InB (channel 2/IGBT 1) have the following functions: input InA is the PWM signal input while input InB acts as the enable input.

When fiber-optic input InB is off (light off), both channels are blocked. If it goes on (light on), both channels are enabled and follow the signal on the input InA . At the transition of input InA from off to on, channel 1 (IGBT 2) turns off immediately and channel 2 (IGBT 1) turns on after a dead time. The dead times are set by RC networks on the 2SB315.

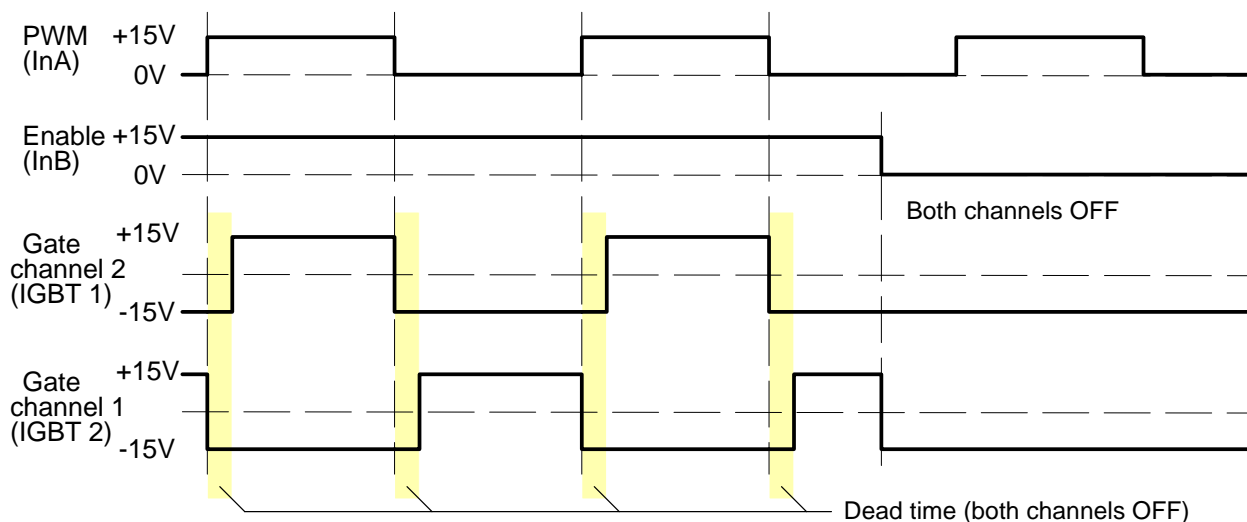

Fig. 3 Signals in half-bridge mode

Direct mode

In this mode, there is no interdependence between the two channels. Fiber-optic input InA directly influences channel 1 (IGBT 2) while input InB influences channel 2 (IGBT 1). Light on at an input (InA or InB) always results in turn-on of the corresponding IGBT. This mode should be selected only when the dead times are generated by the control circuitry so that each IGBT receives its own drive signal. In this mode, both channels can be driven either synchronously or with overlapping timing (i.e. for parallel resonance converters).

Description and Application Manual

Caution: Synchronous or overlapping timing of both switches of a half-bridge basically shorts the DC link.

Description of Fiber-Optic Inputs

These are basically PWM inputs, but their function depends on the *Mod* input (see above).

Description of Fiber-Optic Outputs (status feedback & edge acknowledge)

During normal operation (i.e. the driver is supplied with power at nominal voltage, and there is no fault anywhere), the status feedback is "light on" at the optical link. A malfunction is signaled by "light off".

Each edge of the control signal is acknowledged by the driver with a short pulse (light is off for a period of about 1µs). As this can be observed by the host controller, this method allows simple and continuous monitoring of all drivers and fiber-optic links of the system. Figure 4 shows the control and response signals of a gate driver for normal operation.

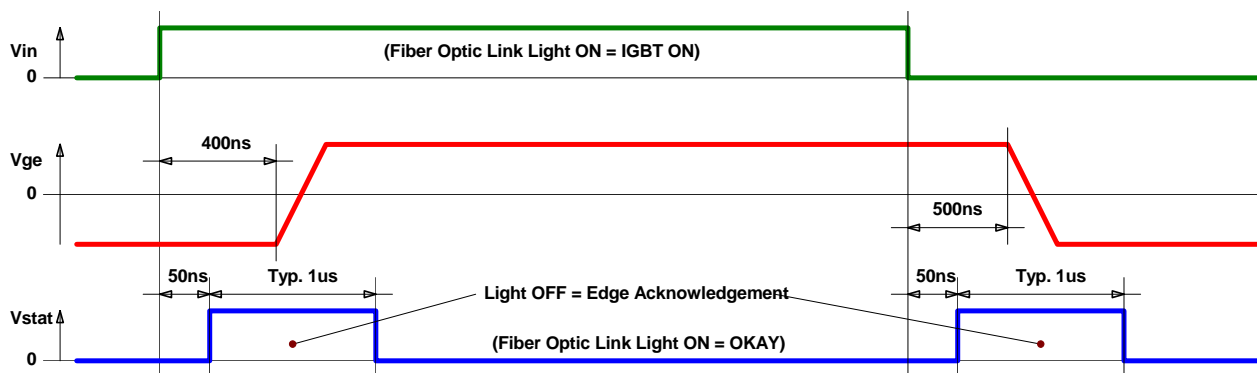

Fig. 4 Driver behavior and status feedback in normal operation

In the failure condition (short-circuit, over-current or power-supply undervoltage), the driver shuts the IGBT off within the response time. The IGBT is kept in the off state for approx. 1 second (blocking time). The failure status is transferred to the status feedback terminal as soon as the switching signal (fiber-optic input) changes. In this case, the fiber-optic output is driven to "light off" for approx. 12ms. After this time it is reset automatically.

Description and Application Manual

N.B. In the failure condition of one channel, the automatic reset circuit causes the channel without failure to be switched off approx. 8ms after a switching signal change of the channel with failure. The channel without failure would be enabled again approx. 4ms later and would be switched on if the input switching signal is on. **So it is absolutely necessary to switch off both channels as soon as one status output goes to the failure condition in order to avoid uncontrolled switching of the channel without failure.**

Figure 5 shows the response of the driver in the case of the failure condition.

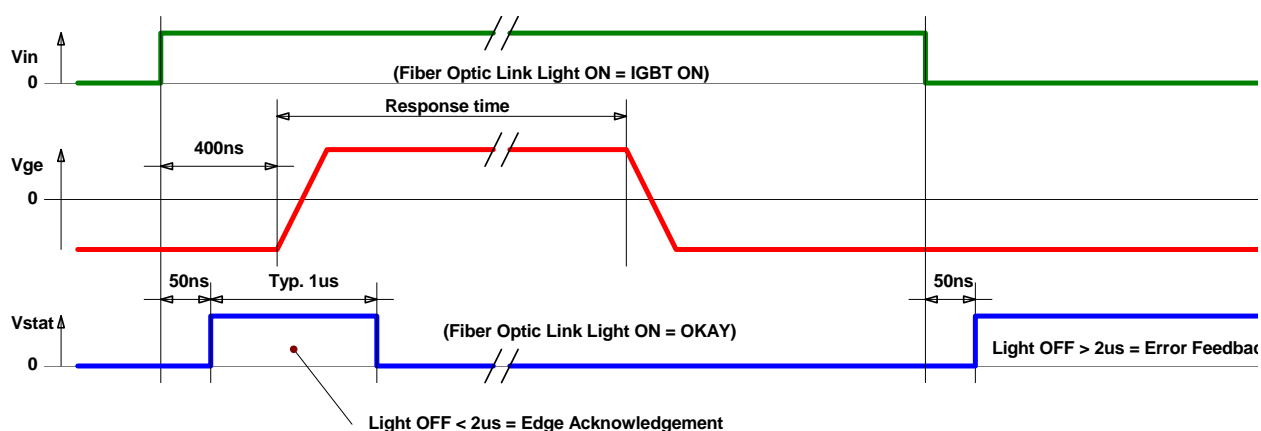

Fig. 5 Failure status feedback; signals under short circuit or over-current conditions

N.B. During power up, the status feedback will also show a failure condition during about 8ms. After this time it is reset automatically.

Description and Application Manual

Recommended Interface Circuitry for Fiber Optics

The fiber-optic links are available in two versions (refer to the relevant data sheet /4/). The recommended circuitry for the fiber-optic links is given in Fig. 6 (standard version) and Fig. 7 (Opt. 1).

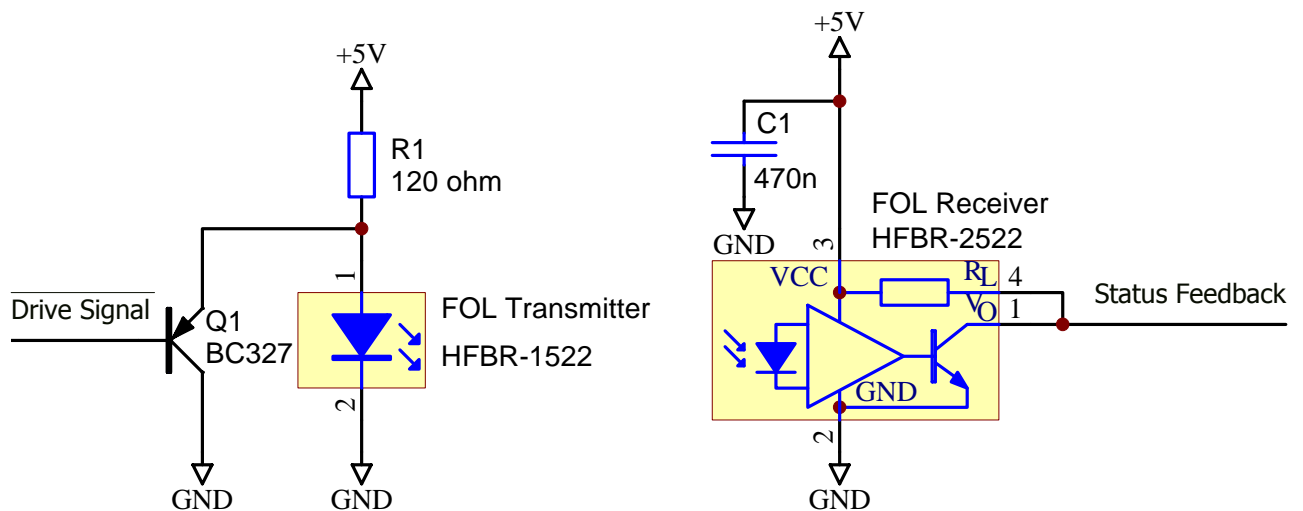

Fig. 6 Recommended circuitry for the "versatile" fiber-optic links (standard version)

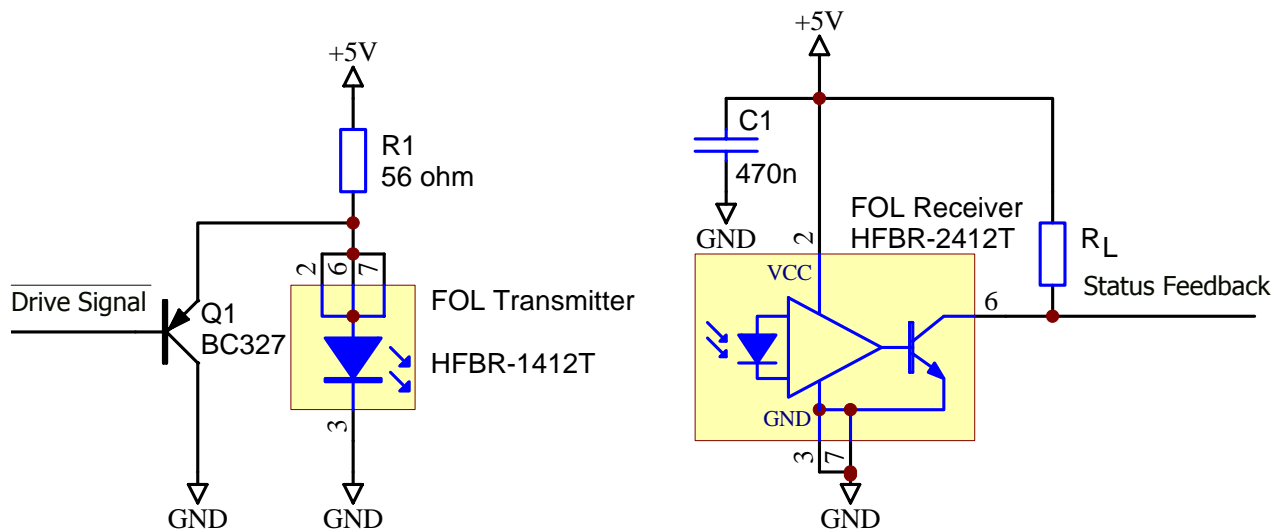

Fig. 7 Recommended circuitry for the "ST" fiber-optic links (Opt. 1)

Description and Application Manual

Protection Concept

Only a brief overview will now be given of the functions of the SCALE driver chipset used here. For further information about the chipset, refer to /1/.

Power-supply monitoring

An under-voltage monitoring circuit blocks the driver if the supply voltage drops below about 10...11V. In this case, the IGBT is driven with a negative gate voltage to keep it in the off-state. A failure condition is transmitted.

The monitoring is performed locally on each gate driver (integrated in the IGD 001).

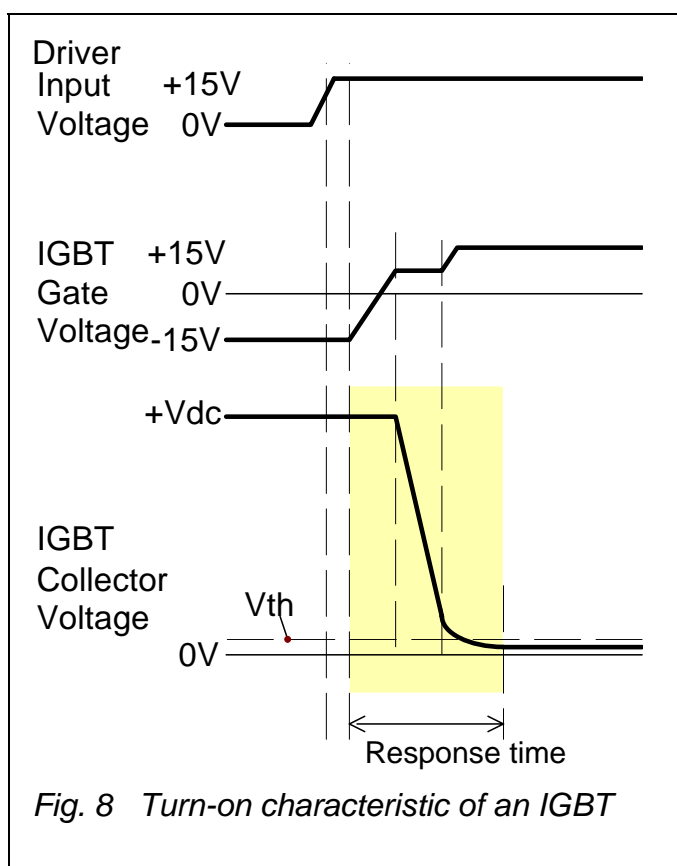
Short-circuit and overcurrent protection

Each channel of a SCALE driver is equipped with a V_{ce} -monitoring circuit. The circuit is inactive during the response time applied to ensure that the IGBT is fully turned on (see Fig. 8).

In the event of failure due to V_{ce} monitoring or power-supply under-voltage lock-out, the IGBT is kept in the off-state for a blocking time during which all drive signals are ignored. The blocking time is applied independently to each channel by IGD 001. It starts when V_{ce} exceeds the threshold of the V_{ce} -monitoring circuit. With the next transition of the drive signal, the "error" information is transferred for storage to the LDI 001, whose respective status output goes to the failure condition. The driver then ignores any drive signal. The error information is reset only about 3.5ms after the first transition in the drive signal.

Active clamping

Simple gate driving leads to the typical turn-off transition shown in Fig. 9. Turn-off with a specified minimum gate resistance is critical, particularly for trench-gate IGBT chips, due to the high rate of decrease of the collector current. To minimize turn-off losses, therefore, the 2SB315B features an active clamping function. This technique is designed to turn the IGBT on partially whenever the collector-emitter voltage exceeds a predefined threshold. The IGBT is then kept in linear operation. The basic circuitry is shown in Fig. 10.

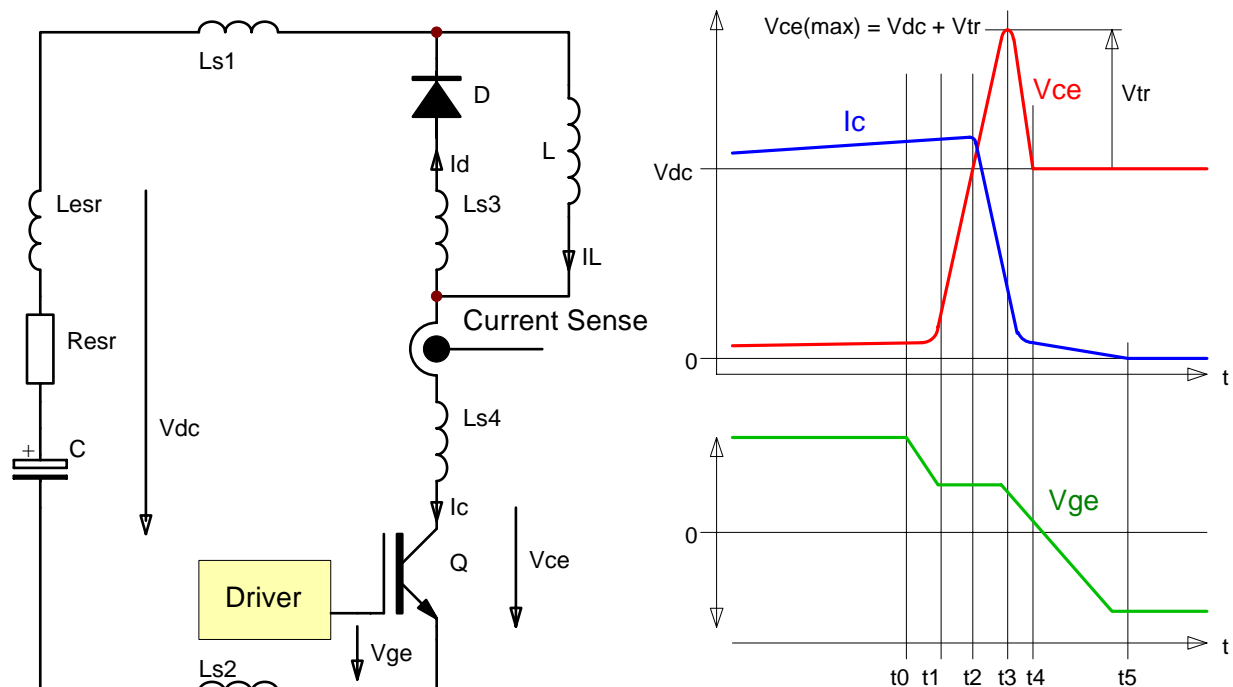

Fig. 9 Test circuit (left) and typical switching characteristics (right)

Legend to Fig. 9

- t0 = Initiation of the turn-off process
- t1 = Start of collector-emitter voltage rise
- t2 = Start of collector current drop
- t3 = Maximum collector-emitter voltage
- t4 = IGBT is blocking, start of tail current
- t5 = End of tail current

Description and Application Manual

In comparison with other driving methods, active clamping allows enhanced utilization of the IGBT modules during normal operation by increasing the switching speed and thus reducing switching losses. Furthermore, active clamping manages the over-voltage under changed operating conditions.

The active clamping function should not lead the user to forget about the inductances of the power stack.

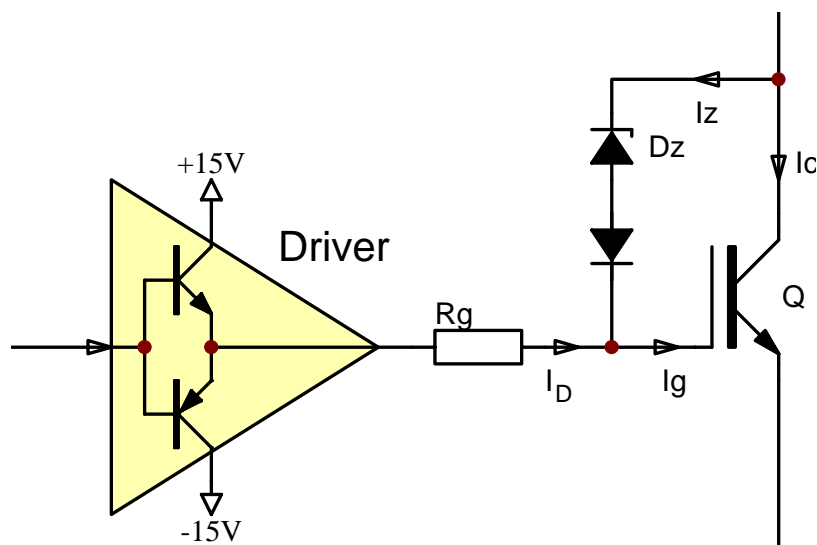

Fig. 10 Basic circuitry for active clamping

Bibliography

- /1/ Description and Application Manual for SCALE Drivers, CONCEPT
- /2/ The "SCALE" IGBT Driver, a new, scalable, compact, all purpose, low cost, easy-to-use driver for IGBTs, H. Rüedi & P. Köhli, PCIM 1998 Proceedings
- /3/ Data sheet 2SD315AI, CONCEPT
- /4/ Data sheets of specific 2SB315, CONCEPT

Note: The paper /2/ is available on the Internet at www.IGBT-Driver.com/go/papers

Description and Application Manual

The Information Source: SCALE Driver Data Sheets

CONCEPT offers the widest selection of gate drivers for power MOSFETs and IGBTs for almost any application needs. The largest website on gate-drive circuitry anywhere contains all data sheets, application notes and manuals, technical information and support sections: www.IGBT-Driver.com

Quite Special: Customized SCALE Drivers

If you need an IGBT driver that is not included in the delivery range, please don't hesitate to contact CONCEPT or your CONCEPT sales partner.

CONCEPT engineers have more than 20 years experience in the development and manufacture of intelligent gate drivers for power MOSFETs and IGBTs and have already implemented a large number of customized solutions.

Evaluation Systems

The evaluation systems used with EconoDual modules are designed particularly for development, verification, qualification and testing. They contain IGBTs, driver boards and DC-link capacitors, completely mounted and 100% tested. CONCEPT offers systems with various heat sinks or without coolers.

For details see: www.IGBT-Driver.com/go/plug-and-play

Customer-Specific Systems

CONCEPT develops and produces complete power equipment and systems according to the customer's specifications.

Description and Application Manual

Consulting and Training

CONCEPT provides consulting and training services to customers on optimal procedures in power control, ideal circuit topologies as well as general do's and don'ts in the development of power electronics.

Technical Support

CONCEPT provides expert help with your questions and problems:

www.IGBT-Driver.com/go/support

Quality

The obligation to high quality is one of the central features laid down in the mission statement of CT-Concept Technologie AG. The quality management system covers all stages of product development and production up to delivery. The drivers of the SCALE series are manufactured according to the ISO9001:2000 quality standard.

Disclaimer

This data sheet specifies devices but cannot promise to deliver any specific characteristics. No warranty or guarantee is given – either expressly or implicitly – regarding delivery, performance or suitability.

CT-Concept Technologie AG reserves the right to make modifications to its technical data and product specifications at any time without prior notice. The general terms and conditions of delivery of CT-Concept Technologie AG apply.

Description and Application Manual

Ordering Information

The general terms and conditions of delivery of CT-Concept Technologie AG apply.

Related IGBT**CONCEPT Driver Type #**

See current list on www.IGBT-Driver.com/go/2SB315B

Information about Other Products**For drivers adapted to other high-voltage or high-power IGBT modules**

Direct link: www.IGBT-Driver.com/go/plug-and-play

For other drivers and evaluation systems

Please click: www.IGBT-Driver.com

Manufacturer

CT-Concept Technologie AG
Intelligent Power Electronics
Renferstrasse 15
CH-2504 Biel-Bienne
Switzerland

Tel. +41 - 32 - 344 47 47
Fax +41 - 32 - 344 47 40

E-mail Info@IGBT-Driver.com
Internet www.IGBT-Driver.com

© Copyright 2005...2008 by CT-Concept Technologie AG - Switzerland.
We reserve the right to make any technical modifications without prior notice.

All rights reserved.
Version of 2008-02-02