

Description and Application Manual

for 2SB315A SCALE Dual-Channel Plug-and-play IGBT Drivers

Driver solution for 130mm x 140mm dual IGBT modules with electrical interface for 2-level topologies

Abstract

The 2SB315A is a dual-channel driver based on CONCEPT's 2SD315AI SCALE driver core, a proven technology for the reliable driving and safe operation of IGBTs.

The driver is matched to several dual IGBT modules with dimensions of 130mm x 140mm. Its plug-and-play capability makes it ready to operate immediately after mounting. The user needs invest no effort in designing or adjusting it to a specific application.

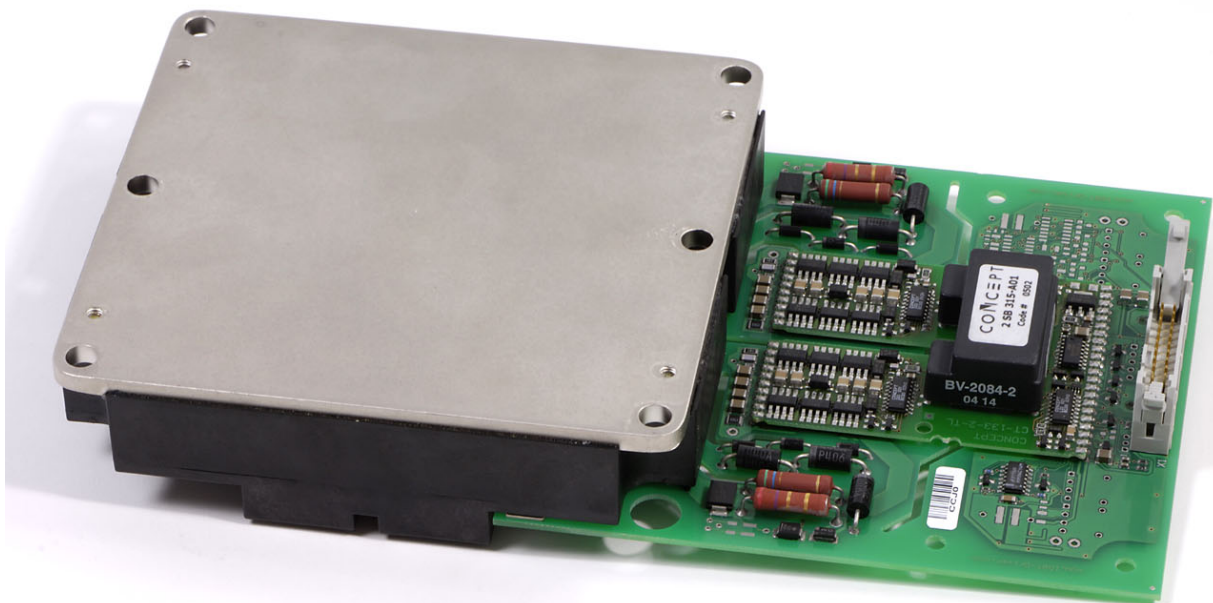

Fig. 1a 2SB315A screwed onto a 130mmx140mm IGBT module (bottom view)

Description and Application Manual

Contents

System Overview	4
The Six Steps to Success.....	5
1. Choose a suitable driver	5
2. Attach the drivers to the IGBT modules.....	5
3. Connect the driver to the control electronics	5
4. Select the operating mode	5
5. Check the driver function	6
6. Set up and test the power stack	6
Pin Designation of Connector X1	7
Recommended Interface Circuitry for Connector X1.....	7
Description of Interface X1.....	8
General.....	8
<i>VDC</i> terminal.....	9
<i>VDD</i> terminal	9
<i>Mod</i> (input, mode selection).....	9
<i>ResetQ</i> (input)	10
<i>InA</i> , <i>InB</i> (channel drive inputs, e.g. PWM)	11
<i>SO1</i> , <i>SO2</i> (status outputs)	11
Protection Concept	13
Power-supply monitoring	13
Short-circuit and overcurrent protection.....	13
Active clamping	14
Bibliography	15
The Information Source: SCALE Driver Data Sheets.....	16
Quite Special: Customized SCALE Drivers.....	16
Evaluation Systems.....	16
Customer-Specific Systems	16
Consulting and Training.....	17
Technical Support	17

Description and Application Manual

Quality 17

Disclaimer 17

Ordering Information 18

Information about Other Products 18

Manufacturer 18

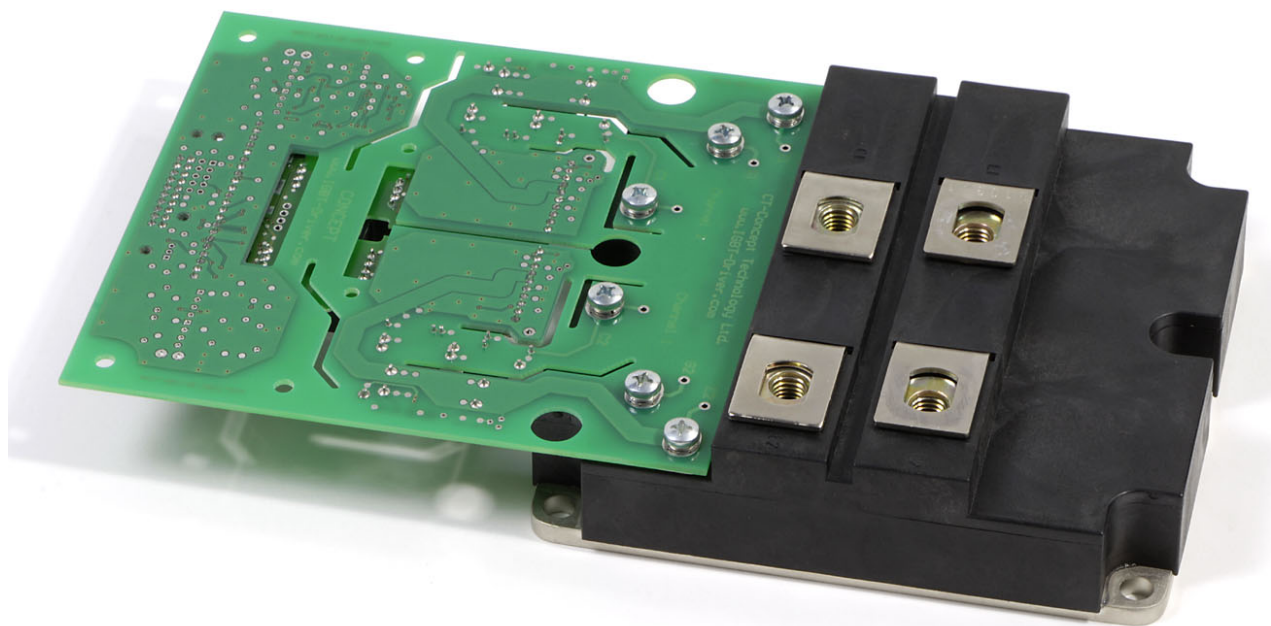

Fig. 1b 2SB315A screwed onto a 130mmx140mm IGBT module (top view)

Description and Application Manual

System Overview

The 2SB315A comprises the standard driver 2SD315AI (see /3/ for more details) mounted on a basic board. It is based on the proven SCALE technology developed by CONCEPT and implemented more than a hundred thousand times. For further information on this technology, refer to /1/, /2/ and /3/.

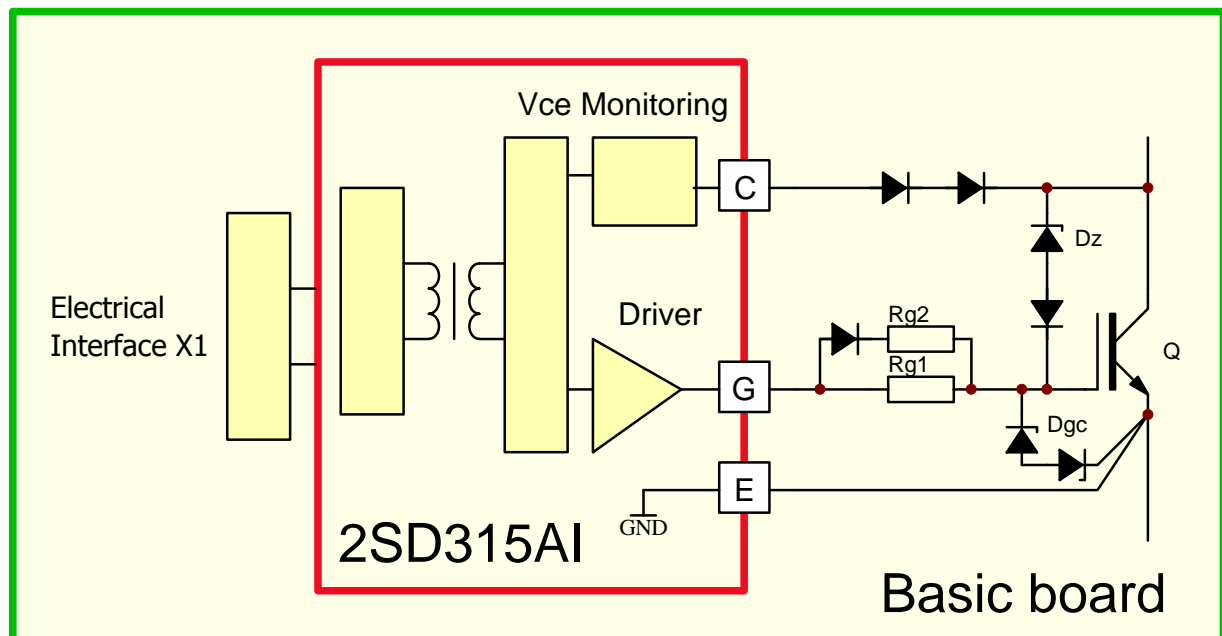

Fig. 2 Separation of universal (red) and IGBT-specific functions (green)

The basic board contains all gate resistors, gate-clamping and active-clamping diodes (overvoltage protection), the diodes for the collector-sense function (surge-current and short-circuit protection) as well as the electrical connector. Moreover, it includes components for setting the turn-off trip level, the response time and the dead time between both channels in half-bridge mode. Its plug-and-play capability means that it is ready to operate immediately after mounting. The user needs invest no effort in designing or adjusting the driver to a specific application.

The driver parameters that must be specifically matched to the IGBT module are placed on the basic board, which is completely assembled and tested by CONCEPT. The basic boards are assembled with the smallest possible gate resistor in order to minimize switching losses. The values for the gate resistors and other key components can be found in the specific datasheets for a given IGBT module.

The Six Steps to Success

The following steps point out the easy way to use 2SB315A drivers in power converters:

1. Choose a suitable driver

When applying 2SB315A drivers, you should note that they are specifically adapted to a particular type of IGBT module.

The type designation of the driver consequently also includes a number corresponding to a specific IGBT module (see "Ordering Information").

These drivers are not valid for IGBT modules other than those specified. Incorrect use may result in failure.

2. Attach the drivers to the IGBT modules



Any handling of IGBT modules or drivers is subject to the general specifications for protecting electrostatic-sensitive devices according to international standard IEC 747-1, Chapter IX or European standard EN 100015 (i.e. the workplace, tools, etc. must comply with these standards).

If these specifications are ignored, both IGBTs and drivers may be damaged.

The driver can be easily mounted onto an IGBT module by screwing the corresponding terminals.

3. Connect the driver to the control electronics

Connect the driver plug X1 to your control electronics and supply the driver with a voltage of +15V.

4. Select the operating mode

The operating mode can be set with input *Mod* (interface *X1*: pin 17). For details, see page 9).

Description and Application Manual

5. Check the driver function

Check the gate voltage: For the off-state, the nominal gate voltage is -15V . For the on-state, it is $+15\text{V}$. Also check the input current consumption of the driver without clock signals and at the desired switching frequency.

It is recommended that these tests be performed before installation, as the gate terminals may otherwise not be accessible.

6. Set up and test the power stack

Before starting up the system, it is recommended that each IGBT module be checked separately under power-cycling conditions. It is usually sufficient to apply the single or double-pulse technique.

Even if only single IGBTs are tested, all the system's gate drivers must be supplied with energy. All the other IGBTs can then be kept in the off state by applying negative gate voltages. This is particularly important when switching the IGBTs under test.

The short-circuit behavior can also be verified at this point.

The system is then ready to start under real-world load conditions. This allows the thermal behavior of the whole arrangement to be determined.

The system must be re-qualified over the entire specified range of temperature and load conditions.



CAUTION: All handling with high voltages involves risk to life.

It is imperative to comply with the respective safety regulations!

Pin Designation of Connector X1

Pin	Des.	Function	Pin	Des.	Function
1	VDC	+15V for DC/DC converter	2	GND	Ground
3	VDC	+15V for DC/DC converter	4	GND	Ground
5	VDD	+15V for electronic input side	6	GND	Ground
7	VDD	+15V for electronic input side	8	GND	Ground
9	SO2	Status output channel 2 (IGBT 1)	10	GND	Ground
11	InB	Input B	12	GND	Ground
13	SO1	Status output channel 1 (IGBT 2)	14	GND	Ground
15	InA	Input A	16	GND	Ground
17	Mod	Input Mod (mode selection)	18	GND	Ground
19	ResetQ	Reset	20	GND	Ground

Note: channel 1 corresponds to IGBT 2 and channel 2 to IGBT 1

Recommended Interface Circuitry for Connector X1

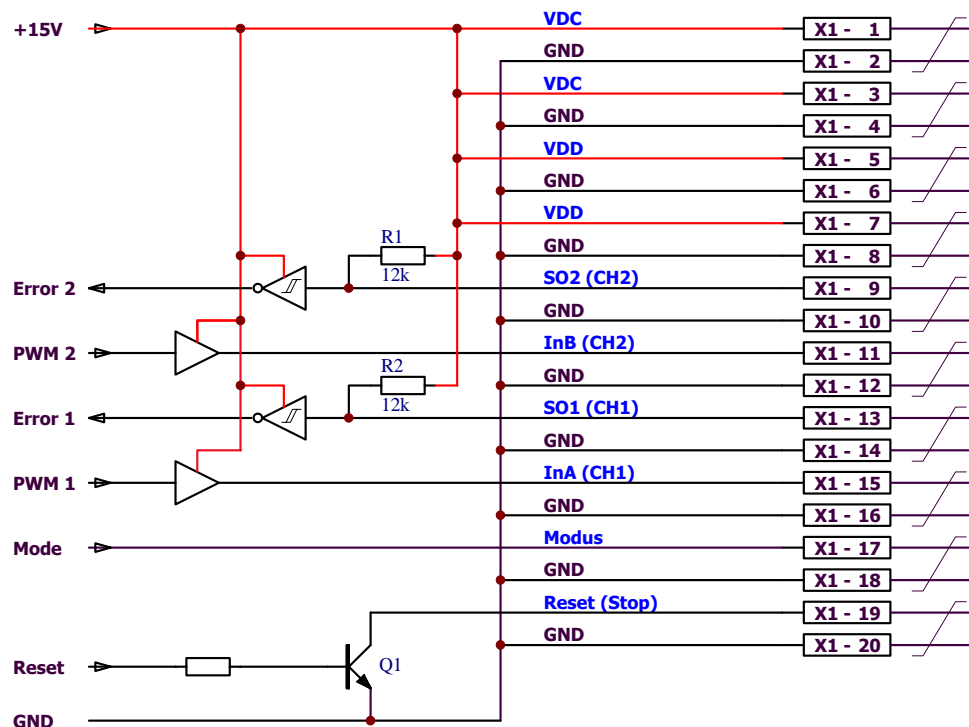

Fig. 3 Recommended user interface of 2SB315

Description and Application Manual

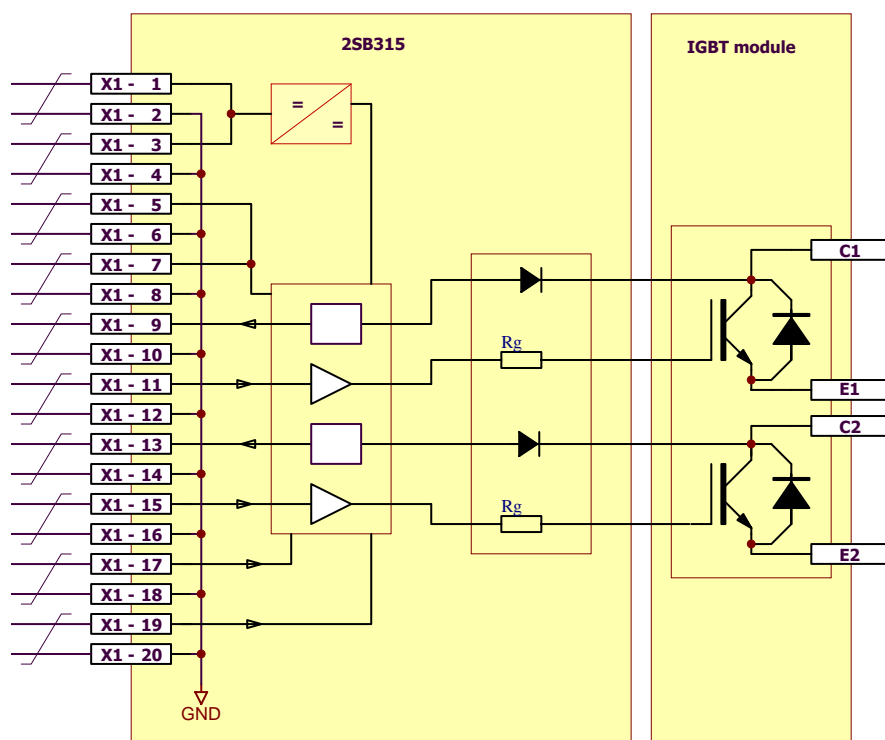

Fig. 4 Block diagram covering SCALE driver 2SB315A and IGBT module

Description of Interface X1

General

The X1 interface of the driver 2SB315A is very simple and easy to use.

The driver has the following terminals:

- 2 x PWM inputs (drive signals)
- 2 x status outputs (failure returns)
- 4 x power-supply terminals (but only one 15V power supply is needed)
- 1 x reset input
- 1 x mode selection (half-bridge mode / direct mode)

The driver is equipped with a 20-pin interface connector. All even-numbered pins are used as the GND connection. The odd-numbered pins are used as inputs or status outputs. It is recommended to use a 20-pin twisted flat cable. Each input and output signal is then twisted with its own GND wire. All GND pins are connected together on the SCALE driver and should be also connected on the control-board side. This

Description and Application Manual

arrangement produces a very low-inductance connection with high immunity against interference.

For improved noise immunity, the driver's input signals have 15V levels (The 5V operating mode of the SCALE chipset is not available for this driver) .

All inputs have Schmitt-trigger characteristics and are ESD-protected by diodes.

VDC terminal

The driver has two *VDC* terminals on the interface connector to supply the DC-DC converters for the secondary sides.

As the driver delivers a total power of $2 \times 3W = 6W$, the maximum input current drawn from the +15V supply is approx. 0.5A (total for terminals *VDC* and *VDD*).

VDD terminal

The driver has two *VDD* terminals on the interface connector to supply the input side of the electronics.

The *VDD* and *VDC* terminals can be connected to a single +15V power supply. A terminal is split into separate pins only for testing.

Mod (input, mode selection)

The *Mod* input allows the operating mode to be selected.

Half-bridge mode

If input *Mod* is low (connected to GND), half-bridge mode is selected, see Fig. 5. In this mode, the inputs *InA* and *InB* have the following functions: *InA* is the PWM signal input while *InB* acts as the enable input.

When input *InB* is low, both channels are blocked. If it goes high, both channels are enabled and follow the signal on the input *InA*. At the transition of *InA* from low to high, channel 1 (IGBT 2) turns off immediately and channel 2 (IGBT 1) turns on after a dead time. The dead times are set by RC networks on the 2SB315.

Description and Application Manual

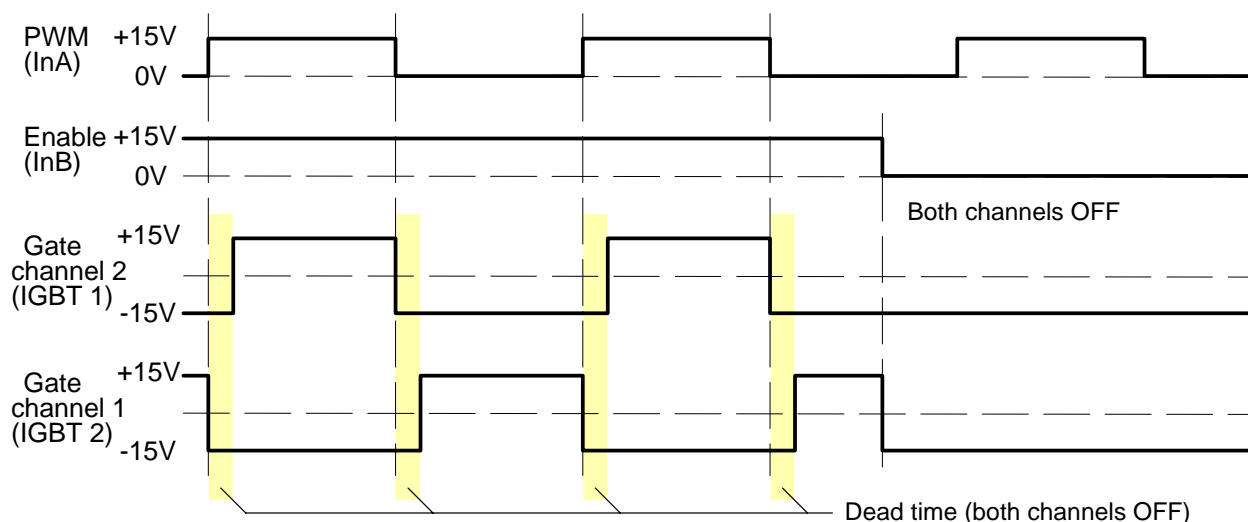

Fig. 5 Signals in half-bridge mode

Direct mode

If input *Mod* is high (connected to *VDD*), direct mode is selected. In this mode, there is no interdependence between the two channels. Input *InA* directly influences channel 1 (IGBT 2) while *InB* influences channel 2 (IGBT 1). High at an input (*InA* or *InB*) always results in turn-on of the corresponding IGBT. This mode should be selected only when the dead times are generated by the control circuitry so that each IGBT receives its own drive signal. In this mode, both channels can be driven either synchronously or with overlapping timing (i.e. for parallel resonance converters).

Caution: Synchronous or overlapping timing of both switches of a half-bridge basically shorts the DC link.

The input *Mod* has a built-in 4k7 pull-up resistor and Schmitt-trigger characteristics.

ResetQ (input)

The terminal *ResetQ* has a built-in 4k7 pull-up resistor and Schmitt-trigger characteristics. If not used, it can be either left open or connected via an additional pull-up resistor to *VDD*.

Description and Application Manual

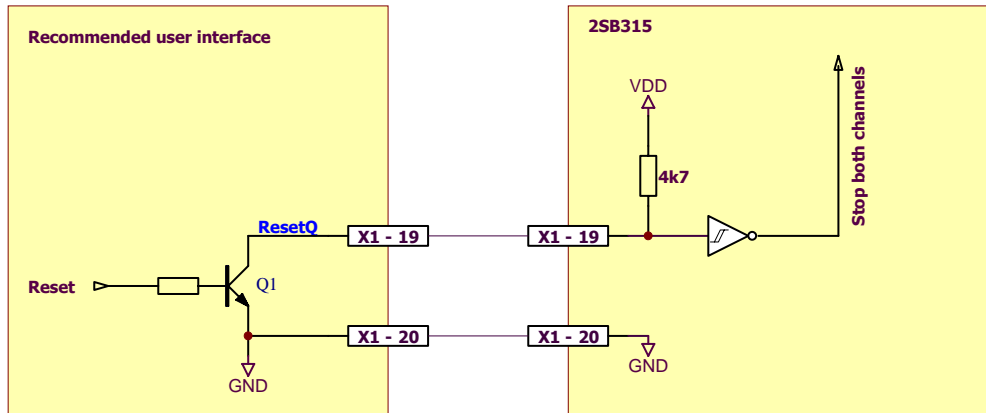

Fig. 6 Recommended user interface, terminal *ResetQ*

If the terminal *ResetQ* is pulled down (by transistor Q1) to GND, then:

- a) The error memory of the driver (in the interface chip LDI 001) is reset, assuming that it had been set earlier
- b) Both driver channels are blocked (both IGBTs are turned off)

The error memories are initially set when the SCALE driver starts up. They can be reset by temporarily connecting the input *ResetQ* to GND (after start-up, controlled by a power-up signal). An automatic reset is then applied to the first edge of the drive signals provided that the blocking time has already elapsed (on both channels). So it is recommended to wait approx. 2 seconds after connecting the supply voltage (*VDD* and *VDC*) to the driver before applying signals to the inputs *InA* or *InB*.

***InA*, *InB* (channel drive inputs, e.g. PWM)**

These are basically PWM inputs, but their function depends on the *Mod* input (see above). These inputs only accept 15V logic (designed for high noise immunity). They have built-in 4k7 pull-down resistors and Schmitt-trigger characteristics.

***SO1*, *SO2* (status outputs)**

The outputs *SOx* have open-collector transistors (see Fig. 7). When an error condition is detected in channel "x", the output goes to low (connected to GND). Otherwise, the output has high impedance.

Both *SOx* outputs can be connected together to provide a common error signal (e.g. for one phase). However, it is recommended to evaluate the status signals individually to allow a fast and precise failure diagnosis.

Description and Application Manual

The outputs SOx can be connected to VDD via a pull-up resistor (the voltage at SOx must not exceed the VDD level). The outputs SOx can handle a maximum current of 1.5mA. To ensure a clean logic signal, it is recommended to apply a filter and a Schmitt trigger gate to SOx .

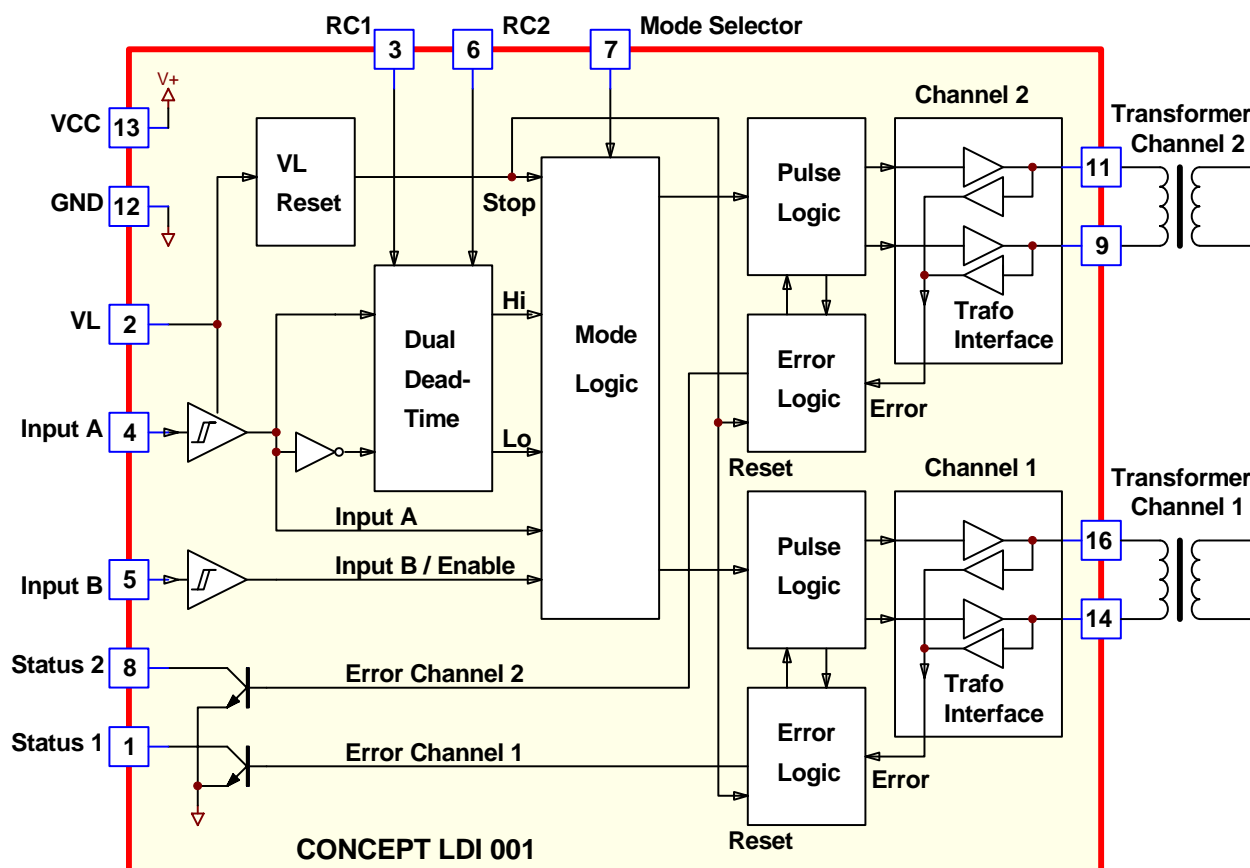

Fig. 7 Block diagram of the LDI 001

How the status information is processed

Each transition in a drive signal leads to:

- An error-memory reset of LDI 001
- Transfer of status information from IGD 001 to LDI 001
- If a failure is detected by IGD 001 (during the blocking time), the error memory in LDI 001 is set.

External reset

The error memory may also be reset by temporarily connecting the input $ResetQ$ to GND. Under a failure condition, the error memory is set with the next transition of the input signal.

Description and Application Manual

Protection Concept

Only a brief overview will now be given of the functions of the SCALE driver chipset used here. For further information about the chipset, refer to /1/.

Power-supply monitoring

An under-voltage monitoring circuit blocks the driver if the supply voltage drops below about 10...11V. In this case, the IGBT is driven with a negative gate voltage to keep it in the off-state. A failure condition is transmitted.

The monitoring is performed locally on each gate driver (integrated in the IGD 001).

Short-circuit and overcurrent protection

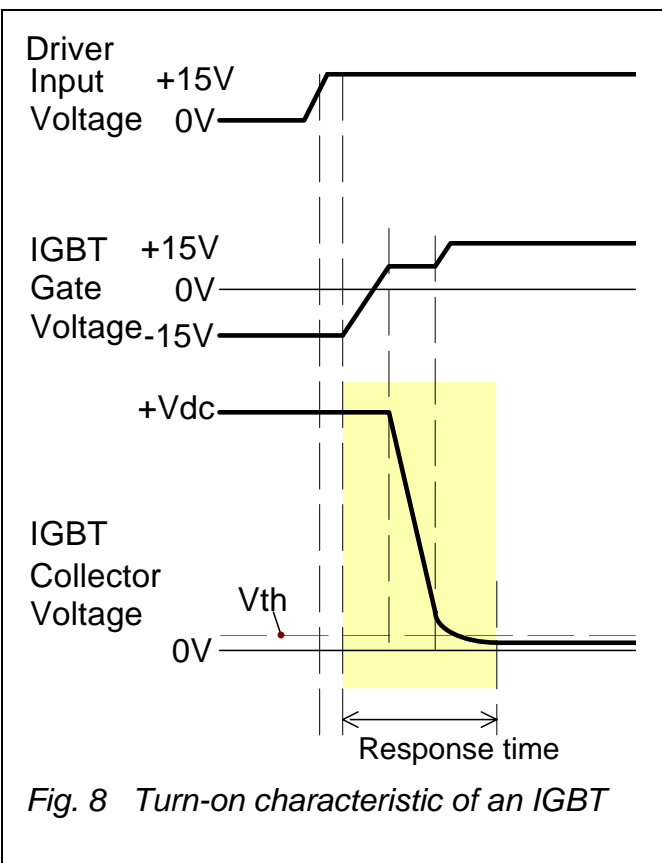

Each channel of a SCALE driver is equipped with a V_{ce} -monitoring circuit. The circuit is inactive during the response time applied to ensure that the IGBT is fully turned on (see Fig. 8).

In the event of failure due to V_{ce} monitoring or power-supply under-voltage lock-out, the IGBT is kept in the off-state for a blocking time during which all drive signals are ignored. The blocking time is applied independently to each channel by IGD 001. It starts when V_{ce} exceeds the threshold of the V_{ce} -monitoring circuit. With the next transition of the drive signal, the "error" information is transferred for storage to the LDI 001, whose respective status output goes to the failure condition. The driver then ignores any drive signal. The error information is reset only at a first transition in the drive signal or by pulling the *ResetQ* terminal to GND after the blocking time expires.

Description and Application Manual

Active clamping

Simple gate driving leads to the typical turn-off transition shown in Fig. 9. Turn-off with a specified minimum gate resistance is critical, particularly for trench-gate IGBT chips, due to the high rate of decrease of the collector current. To minimize turn-off losses, therefore, the 2SB315A features an active clamping function. This technique is designed to turn the IGBT on partially whenever the collector-emitter voltage exceeds a predefined threshold. The IGBT is then kept in linear operation. The basic circuitry is shown in Fig. 10.

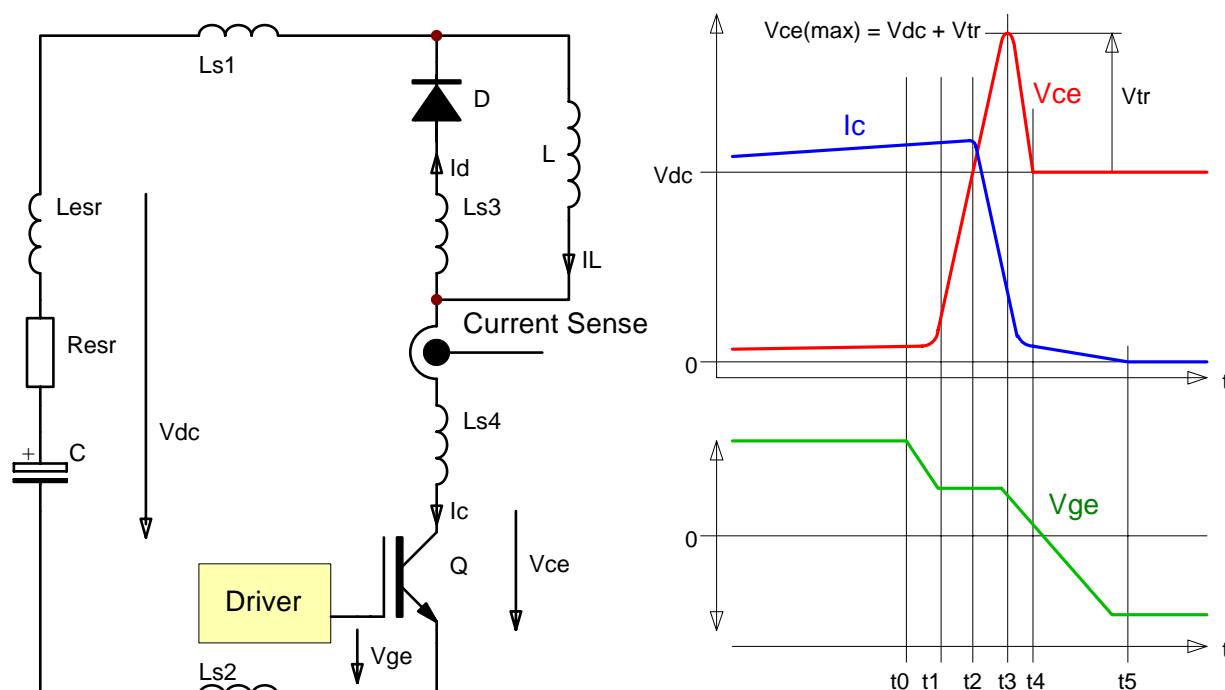

Fig. 9 Test circuit (left) and typical switching characteristics (right)

Legend to Fig. 9

- t_0 = Initiation of the turn-off process
- t_1 = Start of collector-emitter voltage rise
- t_2 = Start of collector current drop
- t_3 = Maximum collector-emitter voltage
- t_4 = IGBT is blocking, start of tail current
- t_5 = End of tail current

Description and Application Manual

In comparison with other driving methods, active clamping allows enhanced utilization of the IGBT modules during normal operation by increasing the switching speed and thus reducing switching losses. Furthermore, active clamping manages the over-voltage under changed operating conditions.

The active clamping function should not lead the user to forget about the inductances of the power stack.

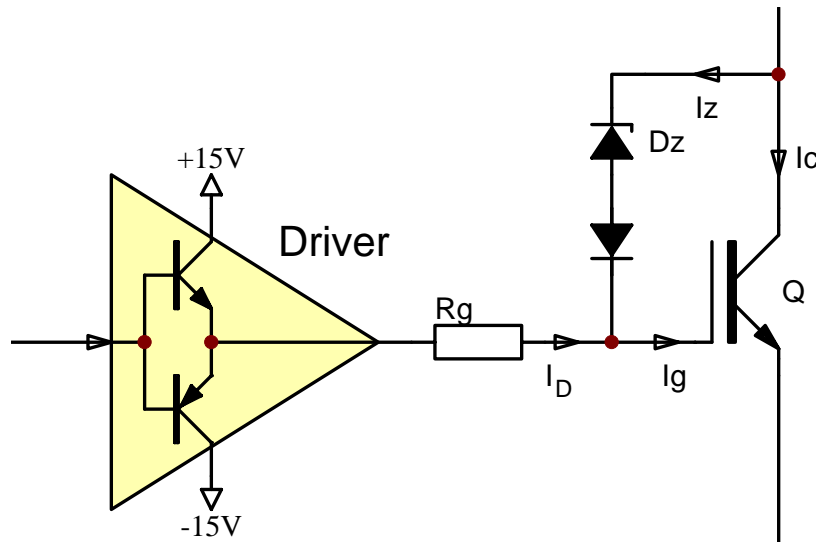

Fig. 10 Basic circuitry for active clamping

Bibliography

- /1/ Description and Application Manual for SCALE Drivers, CONCEPT
- /2/ The "SCALE" IGBT Driver, a new, scalable, compact, all purpose, low cost, easy-to-use driver for IGBTs, H. Rüedi & P. Köhli, PCIM 1998 Proceedings
- /3/ Data sheet 2SD315AI, CONCEPT
- /4/ Data sheets of specific 2SB315A, CONCEPT

Note: All documents are available on www.IGBT-Driver.com

Description and Application Manual

The Information Source: SCALE Driver Data Sheets

CONCEPT offers the widest selection of gate drivers for power MOSFETs and IGBTs for almost any application needs. The largest website on gate-drive circuitry anywhere contains all data sheets, application notes and manuals, technical information and support sections: www.IGBT-Driver.com

Quite Special: Customized SCALE Drivers

If you need an IGBT driver that is not included in the delivery range, please don't hesitate to contact CONCEPT or your CONCEPT sales partner.

CONCEPT engineers have more than 20 years experience in the development and manufacture of intelligent gate drivers for power MOSFETs and IGBTs and have already implemented a large number of customized solutions.

Evaluation Systems

The evaluation systems are designed particularly for development, verification, qualification and testing. They contain IGBTs, driver boards and DC-link capacitors, completely mounted and 100% tested. CONCEPT offers systems with various heat sinks or without coolers.

Customer-Specific Systems

CONCEPT develops and produces complete power equipment and systems according to the customer's specifications.

Description and Application Manual

Consulting and Training

CONCEPT provides consulting and training services to customers on optimal procedures in power control, ideal circuit topologies as well as general do's and don'ts in the development of power electronics.

Technical Support

CONCEPT provides expert help with your questions and problems:

www.IGBT-Driver.com/go/support

Quality

The obligation to high quality is one of the central features laid down in the mission statement of CT-Concept Technology Ltd. The quality management system covers all stages of product development and production up to delivery. The drivers of the SCALE series are manufactured according to the ISO9001:2000 quality standard.

Disclaimer

This data sheet specifies devices but cannot promise to deliver any specific characteristics. No warranty or guarantee is given – either expressly or implicitly – regarding delivery, performance or suitability.

CT-Concept Technology AG reserves the right to make modifications to its technical data and product specifications at any time without prior notice. The general terms and conditions of delivery of CT-Concept Technology AG apply.

Description and Application Manual

Ordering Information

The general terms and conditions of delivery of CT-Concept Technologie AG apply.

Related IGBT

CONCEPT Driver Type

See current list on www.IGBT-Driver.com/go/2SB315A

Information about Other Products

For drivers adapted to other high-voltage or high-power IGBT modules

Direct link: www.IGBT-Driver.com/go/plug-and-play

For other drivers and evaluation systems

Please click: www.IGBT-Driver.com

Manufacturer

CT-Concept Technologie AG
Intelligent Power Electronics
Renferstrasse 15
CH-2504 Biel-Bienne
Switzerland

Tel. +41 - 32 - 344 47 47

Fax +41 - 32 - 344 47 40

E-mail Info@IGBT-Driver.com

Internet www.IGBT-Driver.com

© Copyright 2005...2007 by CT-Concept Technologie AG - Switzerland.
We reserve the right to make any technical modifications without prior notice.

All rights reserved.
Version of 2007-07-09