

Description and Application Manual

for 1SD418F2 SCALE Plug-and-Play IGBT Drivers

Plug-and-play ultra-compact, high-performance, single-channel drivers for 2-level, 3-level and multilevel converters

Abstract

The intelligent gate drivers of the 1SD418F2 SCALE plug-and-play series are advanced, ultra-compact, high-performance, single-channel drive components. They were designed specifically for the precise and reliable driving and perfect protection of high-power and high-voltage IGBT modules.

Product Highlights

- ✓ Perfect driver solution for high-power IGBTs
- ✓ For 2-level, 3-level and multilevel topologies
- ✓ Protects the IGBTs against short circuit
- ✓ Reliable, long service life
- ✓ High gate current of $\pm 18\text{A}$
- ✓ Monitoring of power supply and self-monitoring
- ✓ Duty cycle: 0... 100%
- ✓ Fiber-optic links make long drive cables possible
- ✓ Complete with integrated DC/DC converter
- ✓ Shortens development time

Applications

- ✓ Inverters
- ✓ Traction
- ✓ Motor drive technology
- ✓ Railroad power supplies
- ✓ Medium-voltage converters
- ✓ High-voltage applications
- ✓ Power engineering
- ✓ Switch-mode power supplies
- ✓ Radiology technology
- ✓ Laser power supplies
- ✓ Wind-power converters
- ✓ Research

Description and Application Manual

Contents

Important Note on Technical Information.....	4
SCALE Plug-and-Play Drivers – the Easiest Way to Build Megawatt Converters	5
Seven Steps to Success.....	5
1. Calculate the power dissipation of the IGBT Modules	5
2. Choose a suitable SCALE plug-and-play driver	5
3. Design the power stack.....	5
4. Attach the drivers to the IGBT modules.....	6
5. Select the operating mode	7
6. Perform the functional tests of the drivers.....	7
7. Set up and test the power stack	7
What is a “SCALE Plug-and-Play” Driver?	8
Your Benefit: The Application Advantages of SCALE Drivers	8
Reliable operation.....	8
Electrical insulation	8
Status feedback.....	9
How Do 1SD418F2 SCALE Drivers Work in Detail?	9
Overview	9
Power supply and electrical insulation	10
Undervoltage protection.....	10
V _{ce} monitoring / short-circuit protection	11
Note for traction applications or similar	12
Dynamic behavior of IGBTs.....	12
Turn-on of the IGBT / commutation of diode current	12
Turn-off of the IGBT	13
Active clamping	13
Low-inductance layout.....	15
Interfaces	16
Operating mode	16
Status feedback & edge acknowledge	17
Suggested application-level circuitry for fiber-optic links.....	19

Description and Application Manual

Higher requirements for traction applications or similar..... 19
 Bibliography 20
The Information Source: SCALE Driver Data Sheets..... 21
Quite Special: Customized SCALE Drivers..... 21
Evaluation Systems..... 21
Customer-Specific Systems 21
Consulting and Training..... 22
Technical Support 22
Quality 22
Disclaimer 22
Ordering Information 23
Manufacturer 23

Description and Application Manual

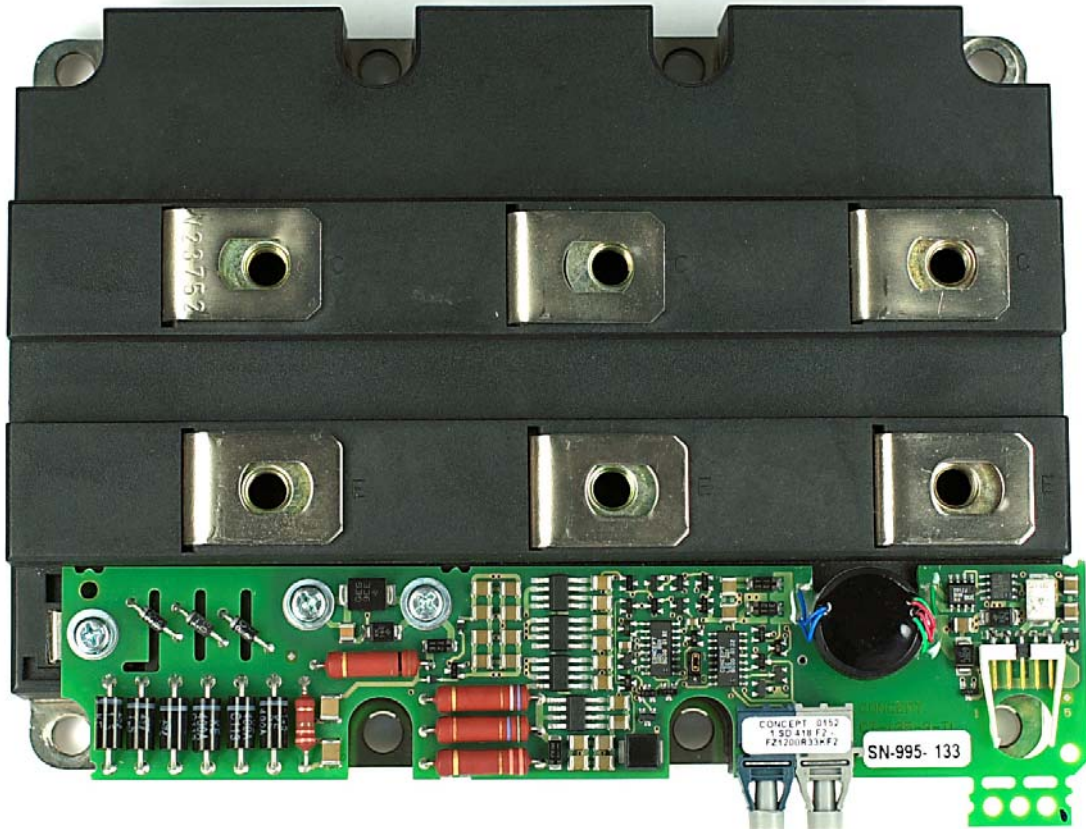

Fig. 1 SCALE plug-and-play driver 1SD418F2 screwed onto a 1200A/3300V IGBT

Important Note on Technical Information

1SD418F2 SCALE plug-and-play drivers are available in several versions in order to satisfy the specific requirements of different IGBT technologies from various manufacturers.

This brief paper covers the general functionality of 1SD418F2 SCALE plug-and-play drivers. For detailed technical data of a specific driver, please refer to the corresponding data sheet.

A list of available SCALE plug-and-play drivers, detailed technical data and application notes can be found on the Internet at:

www.IGBT-Driver.com/go/plug-and-play

SCALE Plug-and-Play Drivers – the Easiest Way to Build Megawatt Converters

The following abstract points out the easy way to design megawatt converters by using superior SCALE plug-and-play technology.

Furthermore, from page 8 you will gain greater insight into SCALE plug-and-play drivers and will find must-read application notes.

Seven Steps to Success

Guide to designing a reliable megawatt converter:

1. Calculate the power dissipation of the IGBT Modules

First choose the IGBT module suited for your application and determine its particular on-state and switching losses. These are used to approximate the size of heat sink required.

Since high-voltage IGBTs have relatively high switching losses, the switching frequency should be limited as much as possible.

2. Choose a suitable SCALE plug-and-play driver

When applying SCALE plug-and-play drivers, please note that these drivers are specifically adapted to a particular type of IGBT module.

Therefore, the type designation of SCALE plug-and-play drivers includes the type designation of the corresponding IGBT module. **These drivers are not valid for IGBT modules other than those specified. Incorrect use may cause failure.**

3. Design the power stack

When designing a power stack, minimize the parasitic inductances. As a rule, a total DC link inductance of about 50nH...100nH should be achievable with reasonable effort.

SCALE plug-and-play drivers are specified and optimized to operate under such conditions, resulting in superior dynamic behavior of the IGBTs.

Description and Application Manual

To speed-up your startup with SCALE plug-and-play drivers, CONCEPT offers ready-to-use evaluation systems; see page 21.

4. Attach the drivers to the IGBT modules

It is quite simple to mount the driver onto an IGBT module by using the three screws enclosed.

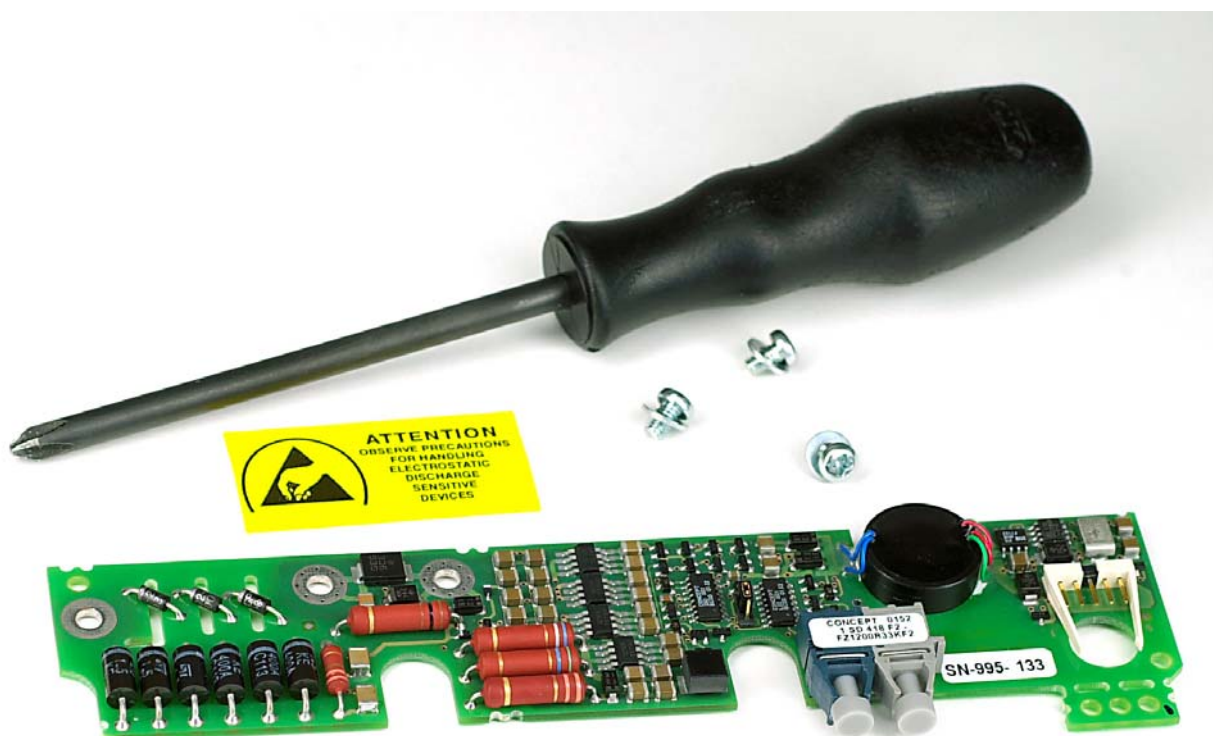

Fig. 2 SCALE plug-and-play driver and the required tool



Any handling of IGBT modules or drivers is subject to the general specifications for protecting electrostatic-sensitive devices according to international standard IEC 747-1, Chapter IX or European standard EN 100015 (i.e. the workplace, tools, etc. must comply with these standards).

If these specifications are ignored, both IGBTs and drivers may be damaged.

5. Select the operating mode

The operating mode is set with jumper J1 according to the specific topology of the power converter. For details see page 16, paragraph "operating mode".

6. Perform the functional tests of the drivers

Attach the driver to the fiber-optic links and to the power supply. Check the gate voltage. For the off-state, the nominal gate voltage is -15V. For the on-state, i.e. with light entering the fiber-optic receiver, the nominal gate voltage is +15V. In addition, check the current consumption of the driver (from the power supply) at the nominal frequency (of the command signal).

It is recommended that these tests be performed before installation, as the gate terminals might otherwise not be accessible.

7. Set up and test the power stack

Before starting up the system, it is recommended that each IGBT module be checked separately under power-cycling conditions. It is usually sufficient to apply the single or double-pulse technique.

Even if only single IGBTs are tested, all the system's gate drivers must be supplied with energy. All the other IGBTs can then be kept in the off state by applying negative gate voltages. This is particularly important when switching the IGBTs under test.

The short-circuit behavior can also be verified at this point.

The system is then ready to start under real-world load conditions. This allows the thermal behavior of the whole arrangement to be determined.

The system must be re-qualified over the entire specified range of temperature and load conditions.

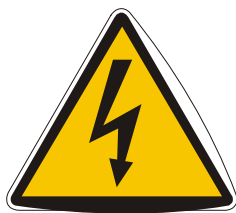

CAUTION: All handling with high voltages involves risk to life.

It is imperative to comply with the respective safety regulations!

Description and Application Manual

What is a "SCALE Plug-and-Play" Driver?

SCALE plug-and-play drivers are based on the sophisticated SCALE driver chipset. This is a set of application-specific integrated circuits (ASICs) that cover the main range of functions needed to design intelligent gate drivers.

"**SCALE**" stands for **S**caleable, **C**ompact, **A**ll-purpose, **L**ow-cost and **E**asy-to-use

This is a concise enumeration of the most outstanding properties of SCALE drivers.

For further information about the SCALE driver chipset, refer to the "Description and Application Manual for SCALE Drivers" /4/.

Your Benefit: The Application Advantages of SCALE Drivers

Reliable operation

1SD418F2 SCALE drivers were developed specifically for the precise and reliable driving and protection of high-power, high-voltage IGBT modules.

Gate driving with a bipolar control voltage (typically $\pm 15V$) allows reliable operation of IGBT modules with high interference immunity.

1SD418F2 SCALE drivers feature an active clamping function, which is the most reliable and effective way of protecting costly IGBTs against overvoltage at turn-off, particularly during conditions of overload and short circuit.

Electrical insulation

1SD418F2 SCALE plug-and-play drivers are equipped with DC/DC converters that provide an insulated power supply for the driver circuitry.

Control signals are applied via external fiber-optic cables. In addition to electrical insulation, this also ensures superior noise immunity even for long signal cables.

Status feedback

A status feedback is transmitted via the fiber-optic interface. This feedback enables the host controller to monitor both gate driver and IGBT. Since each edge of the control signal is acknowledged by this interface, a malfunction of the fiber-optic links can also be detected by the host controller.

How Do 1SD418F2 SCALE Drivers Work in Detail?

Overview

1SD418F2 SCALE drivers are plug-and-play single-channel drivers for high-voltage IGBTs. All drivers of the SCALE driver family are equipped with usual protection functions such as V_{ce} monitoring for short-circuit protection, operation inhibit after fault, supply-undervoltage shutdown and status feedback /3/, /4/.

Outstanding features of 1SD418F2 SCALE drivers are: ultra-compact size, simple mounting - directly onto the IGBT module, advanced active clamping function. Active clamping describes an active scheme to protect the IGBTs against overvoltage during turn-off. It is particularly relevant when turning an IGBT off in cases of high collector current or short circuit.

Description and Application Manual

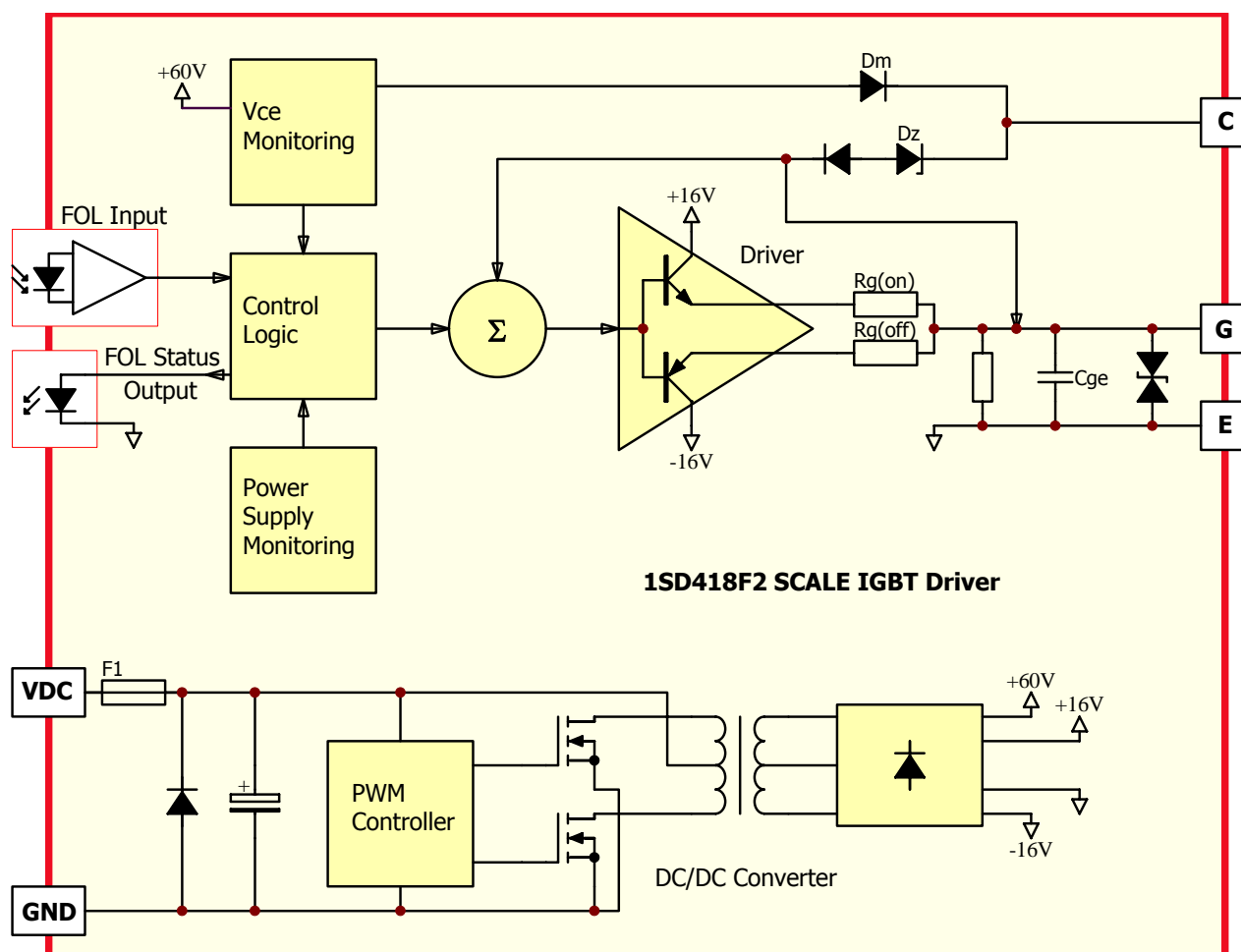

Fig. 3 Block diagram of the 1SD418F2 SCALE driver

Power supply and electrical insulation

The driver is equipped with a DC/DC converter to provide an electrically insulated power supply to the gate driver circuitry. SCALE plug-and-play drivers are designed for the same insulation and test voltages as the corresponding IGBT module. (Refer to the data sheets /1/.) Note that the driver needs a stabilized supply voltage.

An automatic-reset thermal fuse protects the power supply, wiring and driver PCB in case of incorrect polarity or driver defects.

Undervoltage protection

The driver circuitry includes an undervoltage protection function that inhibits the turn-on of an IGBT in case the power supply voltage is too low.

Description and Application Manual

Even in the case of a low power supply voltage, the driver provides a low-impedance path from the IGBT gate to the emitter.

Within a half-bridge, it is advised not to operate the IGBTs with an IGBT driver in the event of a low supply voltage. Otherwise, a high rate of increase of V_{ce} may cause a partial turn-on of these IGBTs.

V_{ce} monitoring / short-circuit protection

The 1SD418F2 SCALE driver provides protection against short circuits on the basis of V_{ce} monitoring, i.e. the collector-emitter voltage is monitored at turn-on and in the on-state.

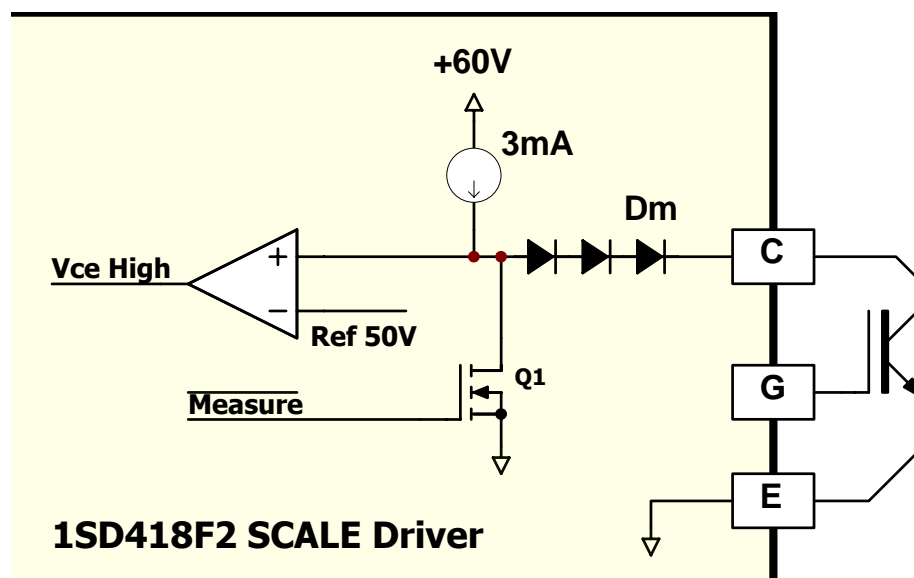

Fig. 4 V_{ce} desaturation monitoring

Figure 4 shows the basic V_{ce} -monitoring circuit implemented in 1SD418F2 SCALE drivers. From the limit of a 60V voltage source, a constant current of 3mA drives the IGBT collector via high-voltage diodes (for the case of $V_{ce} < 60V$). To detect a short circuit, V_{ce} is checked about 8.5 μ s after the turn-on command. If this voltage is higher than 55V, the driver detects a short circuit at the IGBT. This state is locked for a period of 1 second and is fed back to the optical link. (Light is off for 1 second.)

The response of the driver under short-circuit conditions depends on the operating mode set according to the application needs. (For details see page 14.) This means that either the IGBT is immediately turned off or the driver merely transmits an error message to the host controller (via status feedback), which then can turn the IGBTs off either synchronously or sequentially.

Description and Application Manual

The V_{ce} monitoring threshold cannot be changed by the application. A relatively high threshold voltage is required because high-voltage IGBTs, particularly in the case of higher load currents, do not approach the specified saturation voltage within a period of $10\mu s$, which defines the maximum operating time during short circuit to avoid thermal breakdown of the IGBT.

Note: This particular function is for short-circuit detection only and cannot provide overcurrent protection. However, overcurrent detection has a lower time priority and can be easily provided by the application.

Note for traction applications or similar

The vibration withstand capability of 1SD418F2 SCALE drivers can be improved as follows:

- a) Screw-fitting of the driver board to the cooler (see Fig. 14)
- b) Bonding the driver board (bottom side) to the IGBT module.

Dynamic behavior of IGBTs

The dynamic behavior of IGBT modules depends on the type and manufacturer due to the particular behavior of the included IGBT and diode chips, the particular module construction and the distribution of internal gate resistances and inductances. Note that different module types from the same manufacturer may also require a specific gate-driver adaptation.

CONCEPT therefore supplies specific versions of SCALE plug-and-play drivers adapted to the particular IGBT module. **These drivers must not be used with IGBT modules other than those for which they were specified.**

Turn-on of the IGBT / commutation of diode current

When light enters the fiber-optic receiver, the gate driver instructs the IGBT to turn on. The driver already includes the gate resistors, which are matched to the relevant IGBT module.

The driver is optimized to achieve minimum switching losses for the case of relatively low inductances within the power stack. It is recommended to verify the commutation behavior within the final system assembly against the data provided by the IGBT module manufacturer.

Turn-off of the IGBT

The IGBT is turned off when no light enters the fiber-optic receiver. The gate resistors are determined by CONCEPT and must not be altered.

Fast turn-off of the IGBT may cause overvoltage, which increases with increasing DC-link voltage or increasing load current. The turn-off overvoltage can be approximated by:

$$V_{tr} = -L_s * di/dt$$

where V_{tr} is the turn-off overvoltage and L_s the stray inductance.

Most drivers are unable to limit the overvoltage in case of overload and short circuit. However, this is essential for high-power or high-voltage IGBTs. To solve this problem, SCALE plug-and-play drivers provide an active clamping function, which is described below.

Active clamping

Active clamping is a technique designed to partially turn the IGBT on in case the collector-emitter voltage exceeds a predefined threshold. The IGBT is then kept in linear operation. The basic circuitry is shown in Fig. 5.

The 1SD418F2 SCALE driver applies an advanced scheme based on this principle (see the circuit in Fig. 6). For further details, refer to /2/ and /5/.

Description and Application Manual

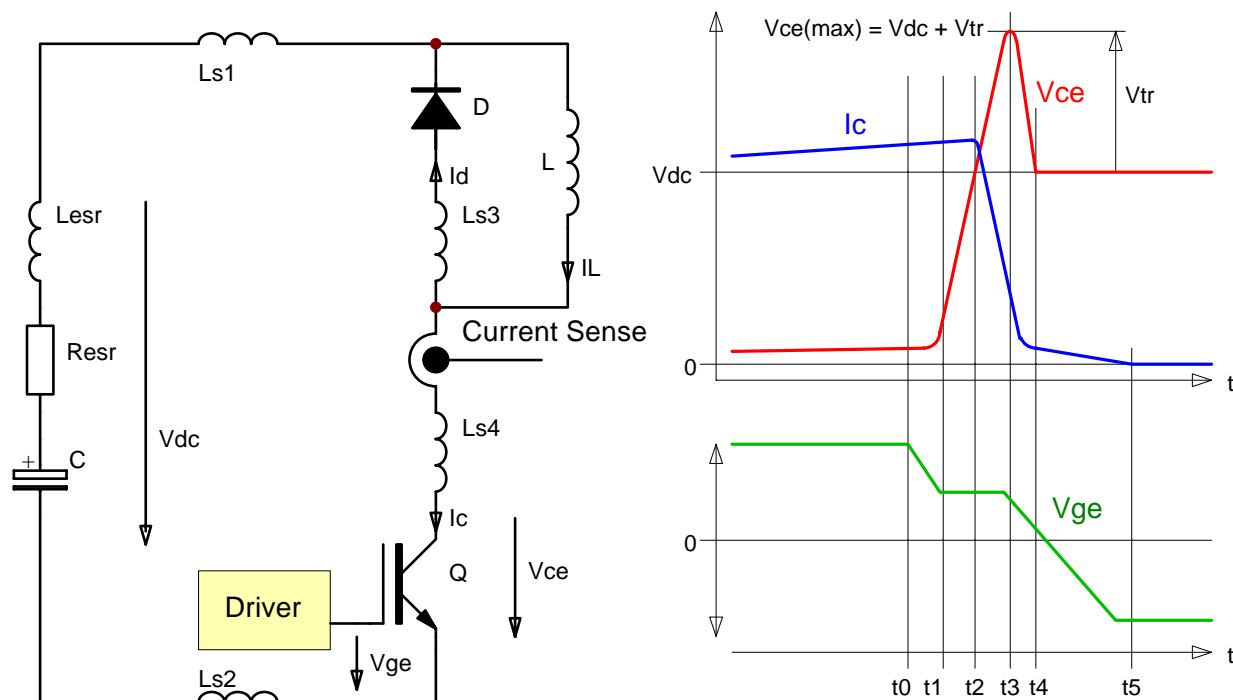

Fig. 5 Test circuit (left) and typical switching behavior (right)

Legend to Fig. 5

- t0 = Initiation of the turn-off process
- t1 = Start of turn-off time
- t2 = Start of collector current fall time
- t3 = Maximum collector voltage
- t4 = IGBT is blocking, start of tail current
- t5 = End of tail current

In comparison with other driving methods, active clamping allows enhanced utilization of the IGBT modules during normal operation by increasing the switching speed and therefore reducing switching losses. The overvoltage at fault-current turn-off is also managed by active clamping. For the maximum permitted DC link voltage, refer to the gate driver data sheets /1/.

Description and Application Manual

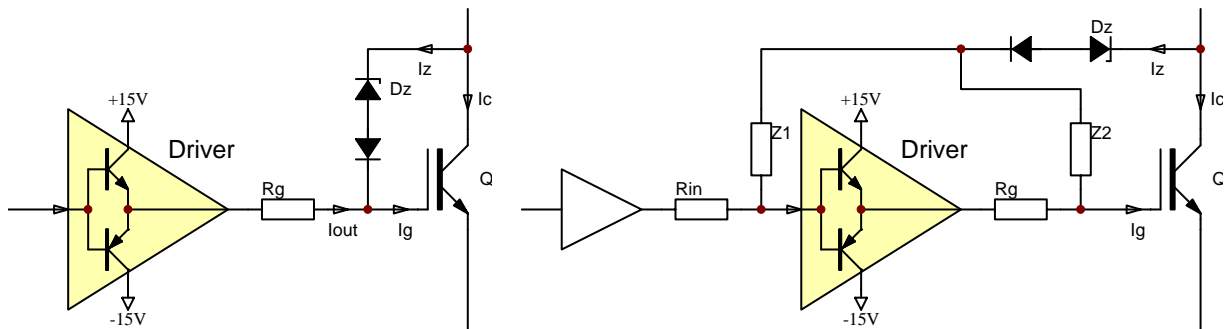

Fig. 6 Basic active clamping circuitry (left) and advanced circuitry used in 1SD418F2 plug-and-play drivers (right)

Figure 7 shows an exemplary turn-off transition of a 1200A/3300V IGBT controlled with a 1SD418F2 driver.

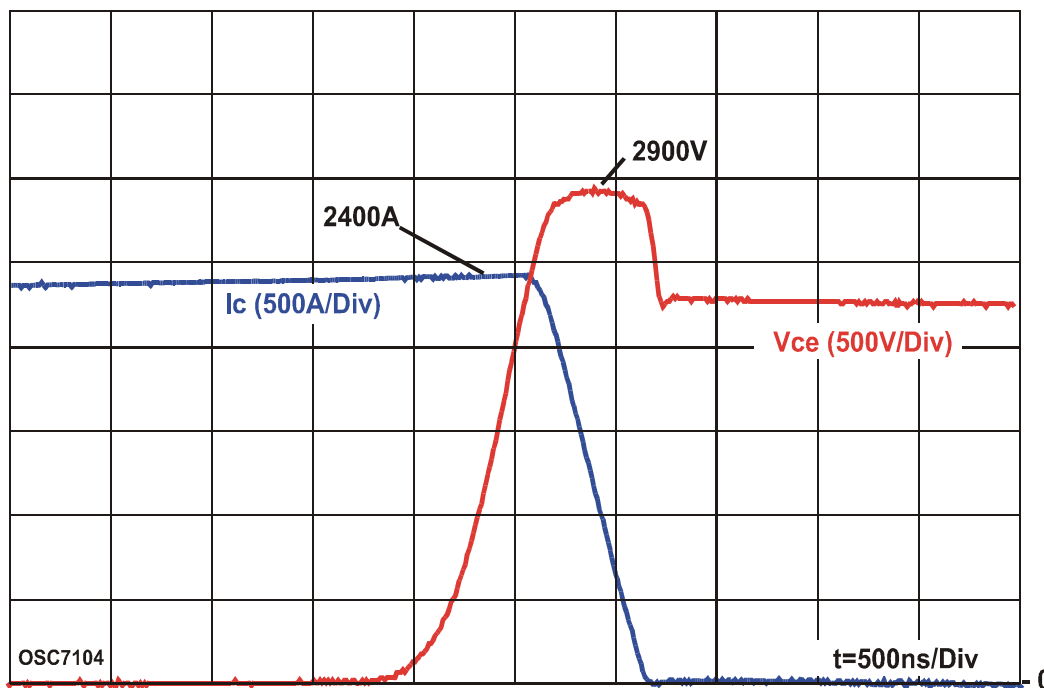

Fig. 7 Behavior of a 1200A/3300V-IGBT for turning off a collector current of 2400A, which is twice the nominal collector current

Low-inductance layout

The active clamping function should not lead anyone to forget about the inductances of the power stack. For several reasons, it is still necessary to reduce the DC-link stray

Description and Application Manual

inductance to between about 50nH and 100nH using high-voltage IGBTs with SCALE plug-and-play drivers. It is not usually advantageous to reduce this inductance further.

Interfaces

Fiber optics are used for the electrical insulation of the command and status-feedback signals. For the type, refer to the data sheets /1/.

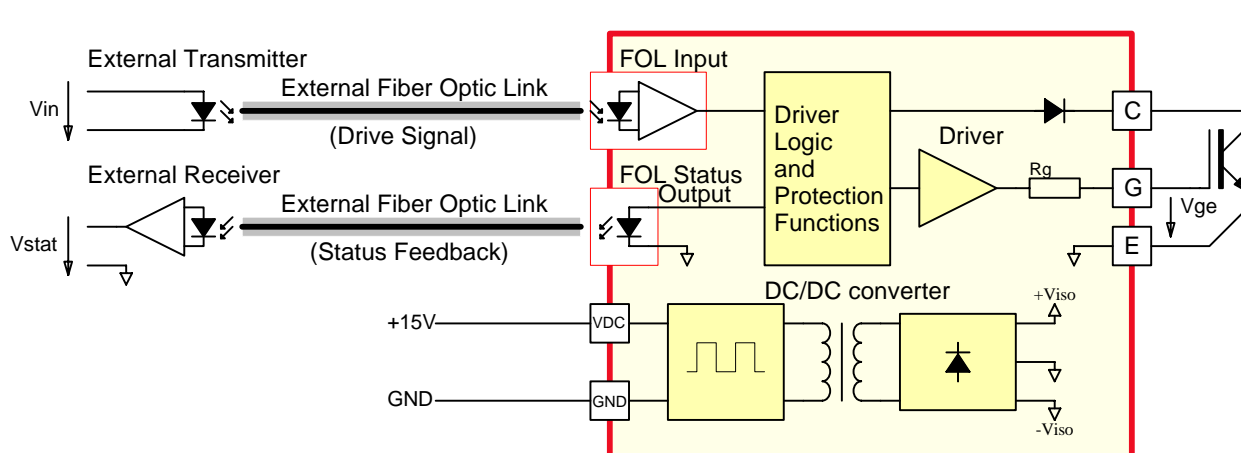

Fig. 8 Test circuit for signal slopes and delay time

The signal delay of a driver, including the external fiber-optic links, is in accordance with the test environment of Fig. 8. For the data, see Figs. 10 and 11.

Operating mode

The appropriate response of a gate driver to a short-circuit event may depend on the specific topology of the power converter. For a conventional 2-level topology, the necessary turn-off of the IGBT can be performed autonomously by the gate driver. This means that the turn-off is controlled locally irrespectively of the actual operation of other IGBTs within the system. To choose this kind of operation, jumper J1 must be set to "2-level mode".

For 3-level or multilevel topologies, the right way to turn the IGBT off under fault conditions is to apply a hierarchical control. That is, the host controller commands the turn-off in response to a locally detected fault. The short-circuit event is therefore transferred to the host controller via the status feedback signal while the IGBT is temporarily kept in its on-state according to the command signal. The appropriate switching sequence of the series-connected IGBTs must then be determined by the host controller. To choose this kind of operation, jumper J1 is set to "3-level-mode".

Description and Application Manual

- J1 → 1-2 = 2-level mode
- J1 → 2-3 = 3-level and multilevel-mode

This jumper is shown in Fig. 9. Jumper positions 1 and 3 are labeled on the circuit board.

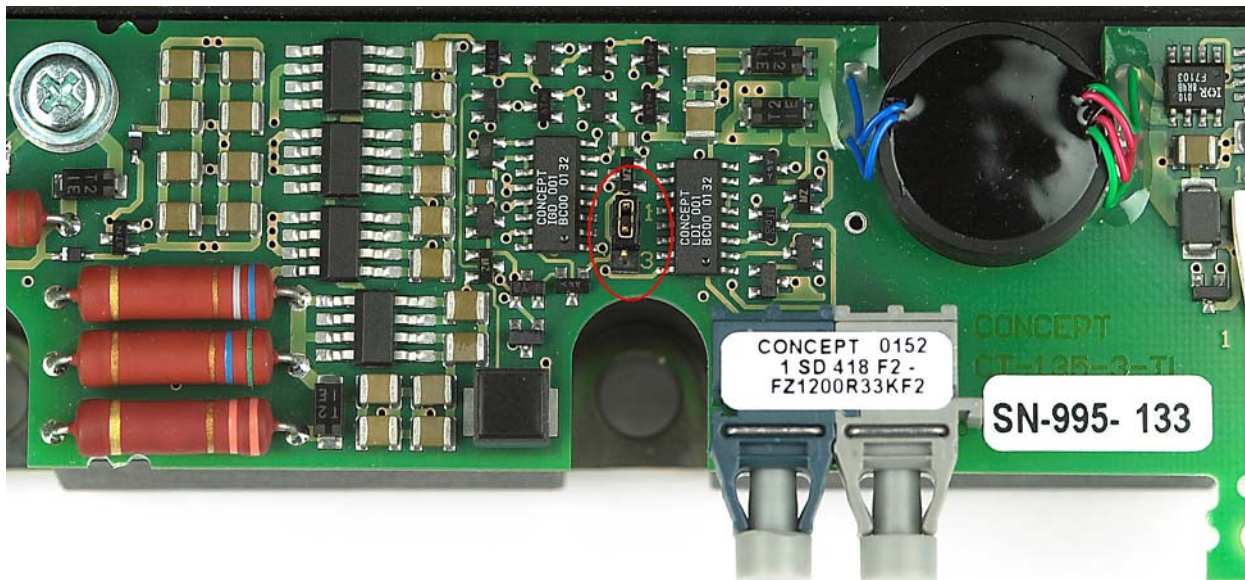

Fig. 9 Jumper J1 used to set the operating mode

Status feedback & edge acknowledge

During normal operation (i.e. the driver is supplied with power at nominal voltage and there is no fault anywhere), the state feedback signals “light on” at the optical link. A malfunction is signaled by “light off”.

The driver acknowledges each edge of the control signal by a short pulse (light is off for a period of about 900ns). As this can be detected by the host controller, this method allows simple and continuous monitoring of all drivers and fiber-optic links in the system.

Figure 10 shows the control and response signals of a gate driver in normal operation. Figure 11 shows the response of the driver in case of a (short-circuit) failure in “2-level mode”. The driver shuts the IGBT off within a maximum delay of 10 μ s (typically 8.5 μ s). The failure status is transferred to the status feedback terminal, which is driven to “light off” for approx. 1 second. Figure 12 shows the response when operating in “3-level-mode”. As for “2-level-mode”, the driver reports an error to the host controller. But the IGBT is kept in the on state until the host controller commands the IGBT to be turned off.

Description and Application Manual

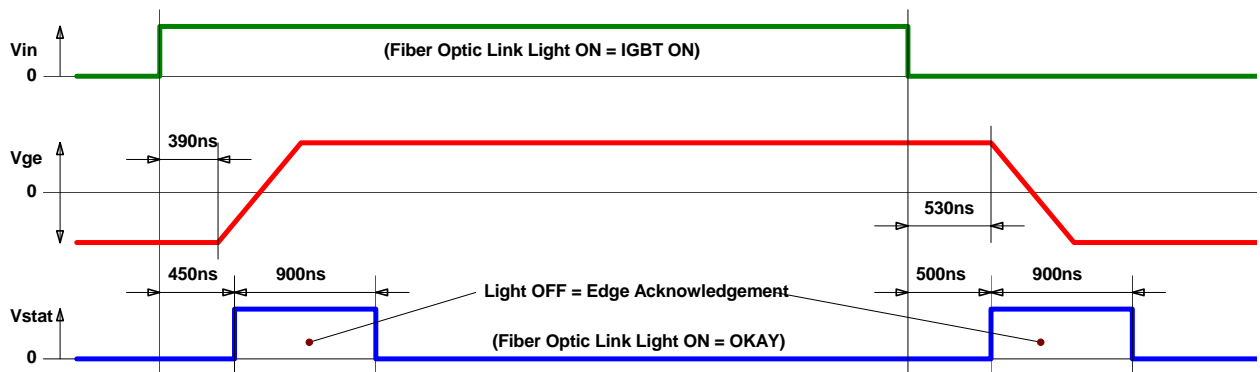

Fig. 10 Failure status feedback; signals for normal operation

It is strongly recommended to have this status signal checked by the host controller. Note that this signal also identifies a malfunction of the fiber-optic links, which may otherwise cause a gate-driver or IGBT defect or a system malfunction.

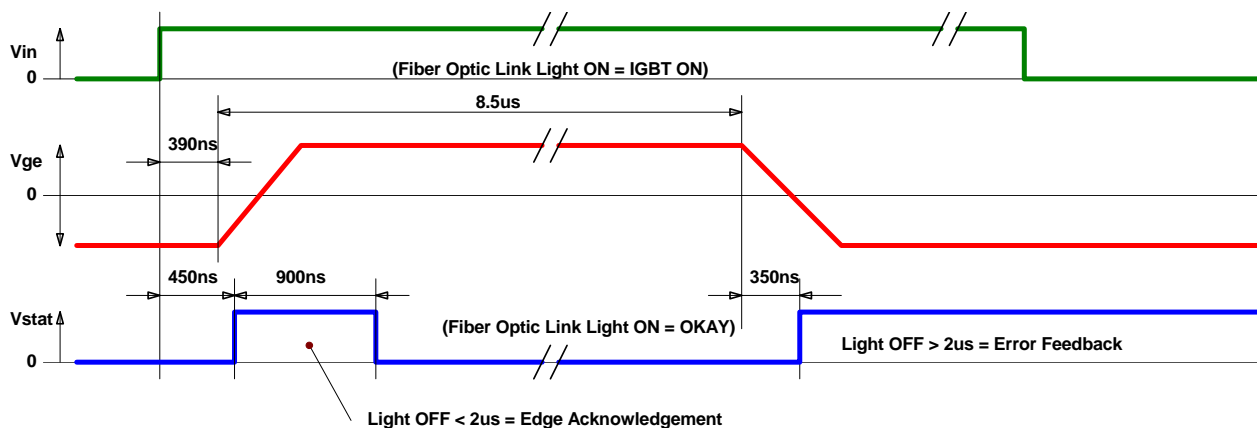

Fig. 11 Failure status feedback; signals under short-circuit conditions in 2-level mode

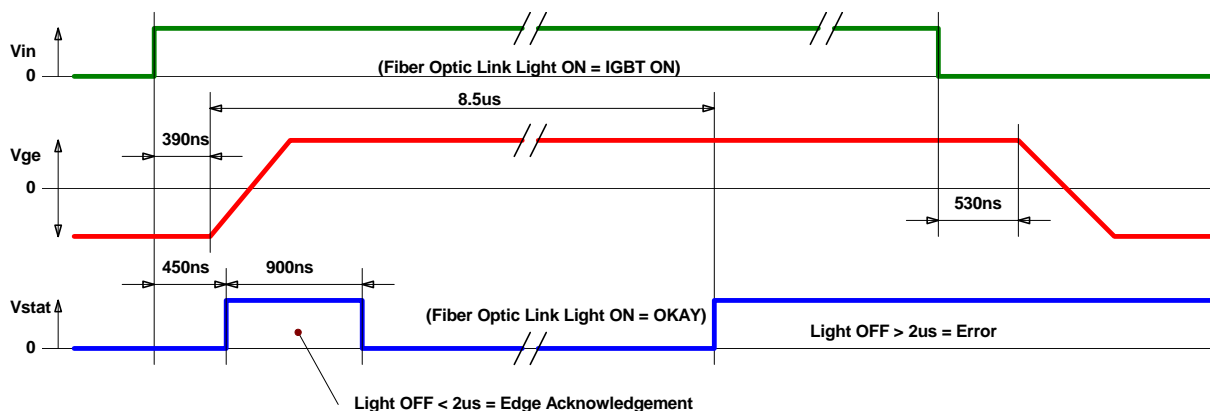

Fig. 12 Failure status feedback; signals under short-circuit conditions in 3-level mode

Suggested application-level circuitry for fiber-optic links

The recommended circuitry for the fiber-optic links is given in Fig. 13. For a typical application (a few meters of optical fiber), the best noise immunity is achieved with a transmitter current of 30mA.

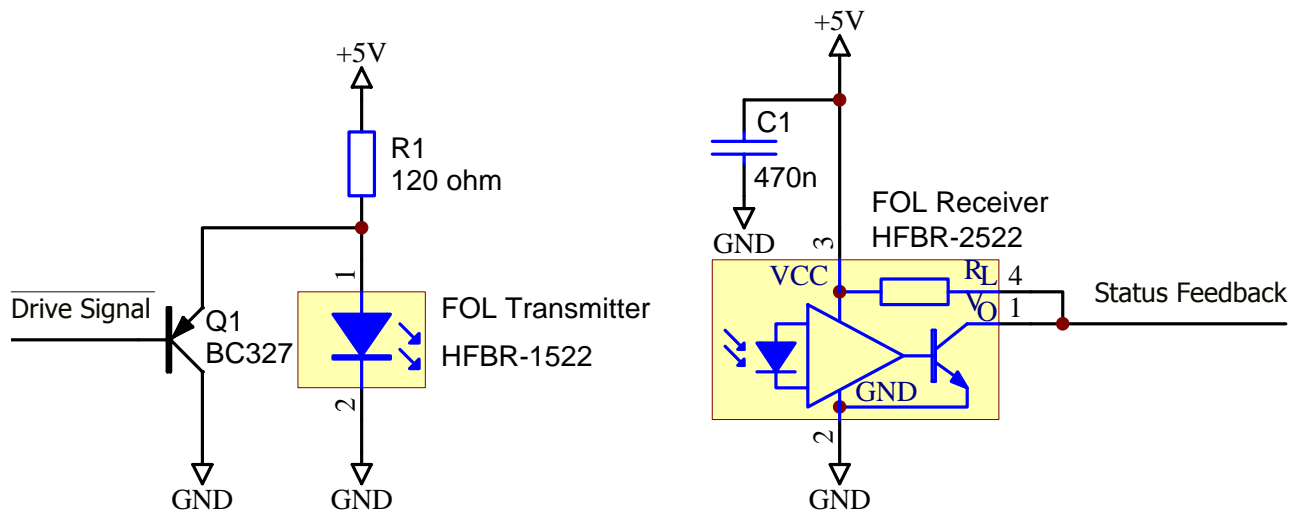

Fig. 13 Recommended circuitry for the fiber-optic links

Higher requirements for traction applications or similar

Basically, the power-supply plug provides a mechanical interlock. If desired, the supply cables could also be fixed at the driver board (see Fig. 14). An interlocking version of the fiber-optic links may also be supplied (see Fig. 14).

Description and Application Manual

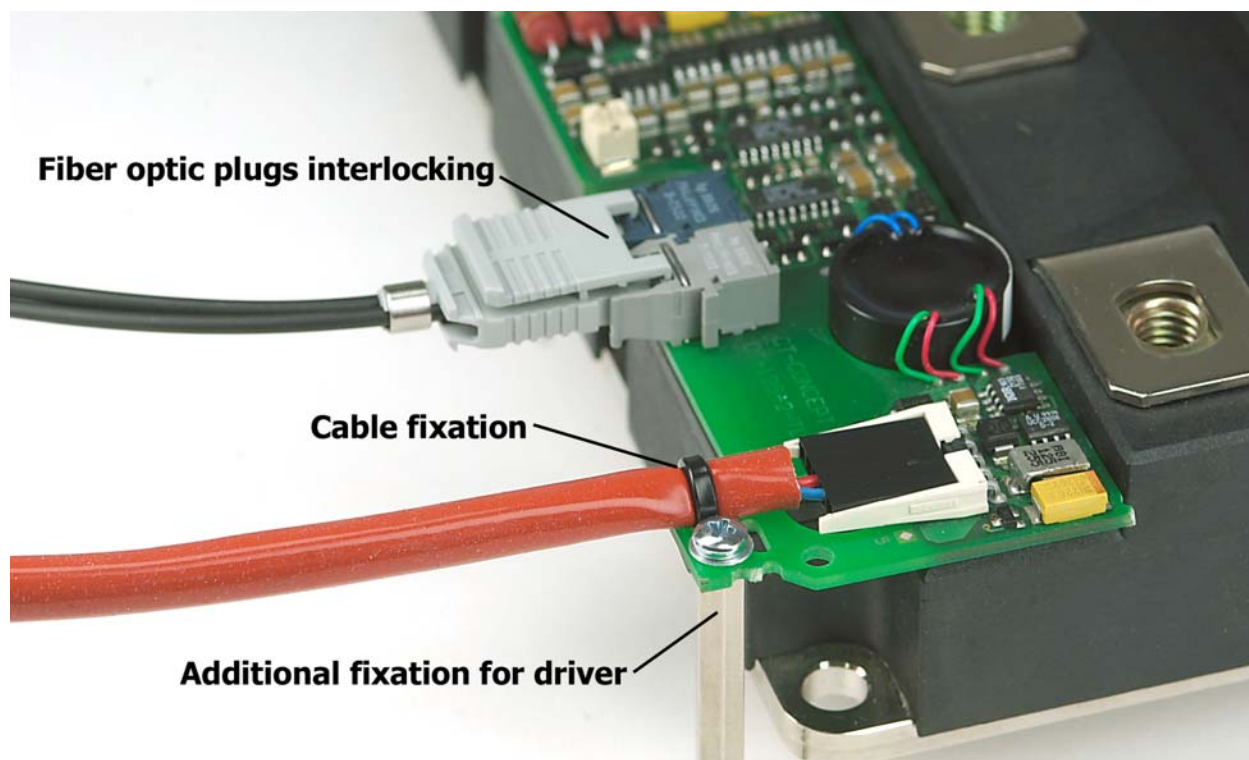

Fig. 14 Additional measures for fixing driver and power-supply cables as well as the relevant version of interlocking fiber-optic links

Bibliography

- /1/ Data sheets SCALE plug-and-play driver 1SD418F2-xxx, CONCEPT
- /2/ "SCALE Driver for High Voltage IGBTs", PCIM 1999 Proceedings
- /3/ "New IGBT Drivers feature active clamping", Power Electronics Europe Magazine 2000 / Issue 1
- /4/ "Description and Application Manual for SCALE Drivers", CONCEPT
- /5/ "Driver Solutions for High-Voltage IGBTs", PCIM Europe Magazine, April 2002

Note: These papers are available on the Internet at www.IGBT-Driver.com/go/papers.

Description and Application Manual

The Information Source: SCALE Driver Data Sheets

CONCEPT offers the widest selection of gate drivers for power MOSFETs and IGBTs for almost any application needs. The largest website on gate-drive circuitry anywhere contains all data sheets, application notes and manuals, technical information and support sections: www.IGBT-Driver.com

Quite Special: Customized SCALE Drivers

If you need an IGBT driver that is not included in the delivery range, please don't hesitate to contact CONCEPT or your CONCEPT sales partner.

CONCEPT engineers have more than 20 years experience in the development and manufacture of intelligent gate drivers for power MOSFETs and IGBTs and have already implemented a large number of customized solutions.

Evaluation Systems

We supply a half-bridge evaluation system with high voltage IGBTs designed particularly for development, verification, qualification and testing. It is fully equipped with high-voltage IGBTs, SCALE plug-and-play drivers, a current sensor, a safety case and, if requested, with IGBT heating for measurements at higher temperature; 100% tested.

For details see: www.IGBT-Driver.com/go/plug-and-play

Customer-Specific Systems

CONCEPT develops and produces complete power equipment and systems according to the customer's specifications.

Description and Application Manual

Consulting and Training

CONCEPT provides consulting and training services to customers on optimal procedures in power control, ideal circuit topologies as well as general do's and don'ts in the development of power electronics.

Technical Support

CONCEPT provides expert help with your questions and problems:

www.IGBT-Driver.com/go/support

Quality

The obligation to high quality is one of the central features laid down in the mission statement of CT-Concept Technology Ltd. The quality management system covers all stages of product development and production up to delivery. The drivers of the SCALE series are manufactured according to the ISO9001:2000 quality standard.

Disclaimer

This data sheet specifies devices but cannot promise to deliver any specific characteristics. No warranty or guarantee is given – either expressly or implicitly – regarding delivery, performance or suitability.

CT-Concept Technology AG reserves the right to make modifications to its technical data and product specifications at any time without prior notice. The general terms and conditions of delivery of CT-Concept Technology AG apply.

Description and Application Manual

Ordering Information**Related IGBT****CONCEPT Driver Type #**

See current list on www.IGBT-Driver.com/go/1SD418F2

Information about Other Products**For drivers adapted to other high-voltage or high-power IGBT modules**

Direct link: www.IGBT-Driver.com/go/plug-and-play

For other drivers and evaluation systems

Please click: www.IGBT-Driver.com

Manufacturer

CT-Concept Technologie AG
Intelligent Power Electronics
Renferstrasse 15
CH-2504 Biel-Bienne
Switzerland

Tel. +41 - 32 - 344 47 47
Fax +41 - 32 - 344 47 40

E-mail Info@IGBT-Driver.com
Internet www.IGBT-Driver.com

© Copyright 1999...2007 by CT-Concept Technologie AG - Switzerland.
We reserve the right to make any technical modifications without prior notice.

All rights reserved.
Version from 2007-06-11