Reference Design Report

Title	26.5 W Dual Output Isolated Flyback Power Supply Using TNY5073K
Specification	85 – 265 VAC Input; 12 V / 2 A Output and 5 V / 0.5 A Output
Application	Appliance
Author	Applications Engineering Department
Document Number	RDR-1016
Date	May 20, 2026
Revision	C

Summary and Features

- Up to 150 kHz switching frequency for small transformer
- Dual output power supply
- >86% full load efficiency at 115 VAC and >87% full load efficiency at 230 VAC
- >85.5% average efficiency at 115 VAC and 230 VAC
- <50 mW no-load input power at 230 VAC
- Delivers 26.5 W output power from 85 VAC to 265 VAC
- Extensive protection features including
 - Line Under Voltage Protection
 - Line Over Voltage Protection
 - Over Temperature Protection (OTP)
 - Short Circuit Protection
 - Over Power Protection
- Class B Conducted EMI with > 6 dB margin

PATENT INFORMATION

The products and applications illustrated herein (including transformer construction and circuits external to the products) may be covered by one or more U.S. and foreign patents, or potentially by pending U.S. and foreign patent applications assigned to Power Integrations. A complete list of Power Integrations' patents may be found at www.power.com. Power Integrations grants its customers a license under certain patent rights as set forth at <https://www.power.com/company/intellectual-property-licensing/>.

Power Integrations

5245 Hellyer Avenue, San Jose, CA 95138 USA.
Tel: +1 408 414 9200 Fax: +1 408 414 9201
www.power.com

Table of Contents

1	Introduction.....	5
2	Power Supply Specification.....	6
3	Schematic.....	7
4	Circuit Description	8
4.1	Input EMI Filtering and Rectification.....	8
4.2	TinySwitch-5 Primary	8
4.3	Output Rectification	8
4.4	Output Rectification	9
5	PCB Layout.....	10
5.1	PCB Specification	10
6	Bill of Materials	11
6.1	Electrical BOM	11
6.2	Mechanical BOM	12
7	Transformer Specification	13
7.1	Electrical Diagram.....	13
7.2	Electrical Specifications	13
7.3	Material List	13
7.4	Transformer Build Diagram.....	14
7.5	Transformer Instructions.....	14
7.6	Transformer Winding Illustrations	15
8	Design Spreadsheet.....	19
9	Performance Data	27
9.1	Full Load Efficiency vs. Line	27
9.2	Line Regulation	28
9.3	Efficiency vs. Load	29
9.4	Load Regulation	32
9.5	Average and 10% Efficiency	33
9.5.1	Average and 10% Efficiency at 115 VAC	33
9.5.2	Average and 10% Efficiency at 230 VAC	33
9.6	No-Load Input Power.....	34
9.7	Standby Input Power	35
9.7.1	Standby Efficiency.....	35
9.7.2	Power Available during Standby	36
9.8	Cross Regulation.....	37
9.8.1	Cross Regulation with 12 V at Minimum Load and Varying 5 V Load	37
9.8.2	Cross Regulation with 12 V at Full Load and Varying 5 V Load	38
9.8.3	Cross Regulation with 5 V at Minimum Load and Varying 12 V Load	39
9.8.4	Cross Regulation with 5 V at Full Load and Varying 12 V Load	40
10	Waveforms.....	41
10.1	Switching Waveforms.....	41
10.1.1	Primary MOSFET Drain-Source Voltage and Current at Normal Operation.	41
10.1.2	Primary MOSFET Drain-Source Voltage and Current at Start-up Operation	43
10.1.3	12V Freewheeling Diode Voltage at Normal Operation.....	45



10.1.4	12V Freewheeling Diode Voltage at Start-Up	47
10.1.5	5V Freewheeling Diode Voltage at Normal Operation.....	49
10.1.6	5V Freewheeling Diode Voltage at Start-Up	51
10.1	Output Start-up	53
10.1.1	Full Load CC Mode	53
10.1.2	Full Load CR Mode	54
10.1.3	No Load	55
10.2	Load Transient Response	56
10.2.1	Transient 5 V _{OUT} 10% - 100% Load and 12 V _{OUT} fixed at 10% Load	56
10.2.2	Transient 5 V _{OUT} 10% - 100% Load and 12 V _{OUT} fixed at 100% Load	57
10.2.3	Transient 12 V _{OUT} 10% - 100% Load and 5 V _{OUT} fixed at 10% Load	58
10.2.4	Transient 12 V _{OUT} 10% - 100% Load and V _{OUT} fixed at 100% Load	59
10.3	Output Voltage Ripple	60
10.3.1	Ripple Measurement Technique	60
10.3.2	Measurement Results	61
10.3.3	Output Ripple Voltage Graph.....	66
10.4	Thermal Performance.....	67
10.4.1	85 VAC Full Load at 25 °C Ambient.....	67
10.4.2	265 VAC Full Load at 25 °C Ambient.....	69
11	Fault Condition	71
11.1	Output Short-Circuit Protection	71
11.2	Overpower Protection	74
11.3	Over Temperature Protection.....	75
12	Conducted EMI	77
12.1	Test Set-up Equipment.....	77
12.1.1	Equipment and Load Used	77
12.2	Output Float.....	78
13	Line Surge.....	79
13.1	Differential Mode Surge.....	79
13.2	Common Mode Surge – Ring Wave	81
13.3	EFT Burst.....	82
14	ESD	84
15	Bode Plot	86
16	Revision History	87



Important Note:

Although this board is designed to satisfy safety isolation requirements, the engineering prototype has not been agency approved. Therefore, all testing should be performed using an isolation transformer to provide the AC input to the prototype board.



1 Introduction

This engineering report describes a flyback converter that provides an isolated output voltage of 12 V at 2 A and 5 V at 500 mA across wide input voltage range of 85 VAC to 265 VAC. This power supply utilizes the TNY5073K from the TinySwitch™-5 family of ICs.

This document contains the power supply specification, bill of materials, transformer construction information, circuit schematic and printed circuit board layout, along with performance data and electrical waveforms.

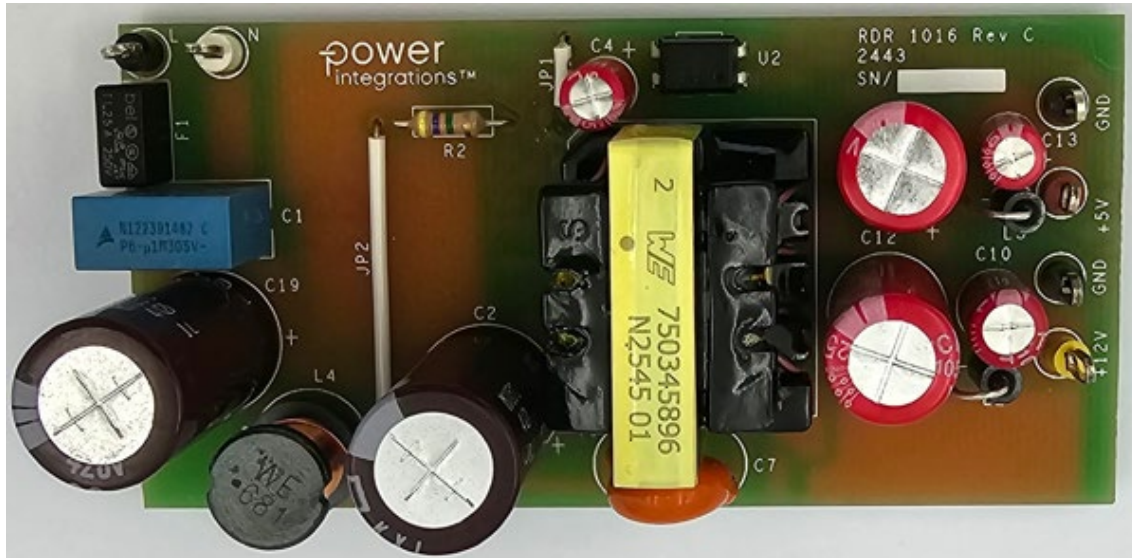

Figure 1 – Top View.

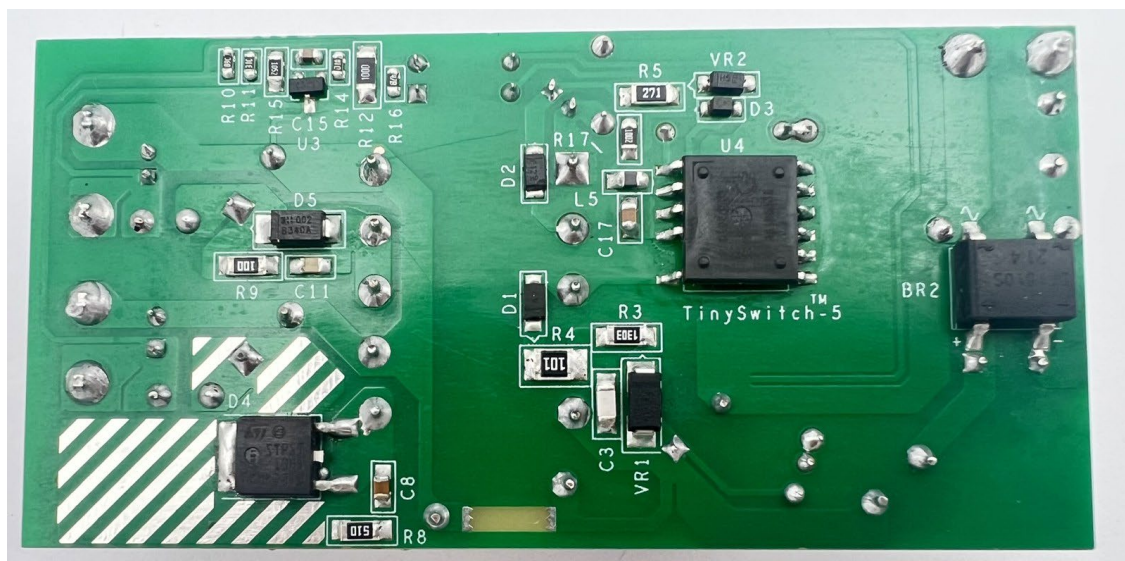

Figure 2 – Bottom View.

2 Power Supply Specification

The table represents the minimum acceptable performance for the design. Actual performance is listed in the results section.

Description	Symbol	Min	Typ	Max	Units	Comment
Input						
Voltage	V_{IN}	85		265	VAC	2 Wire – no P.E.
Frequency	f_{LINE}	47	50/60	64	Hz	
No-load Input Power (230 VAC)				50	mW	
Output1						± 10% at Line/Load Voltage Regulation 20 MHz Bandwidth.
Output Voltage	V_{OUT1}	11.4	12	12.6	V	
Output Ripple Voltage	$V_{RIPPLE1}$			150	mV	
Output Current	I_{OUT1}	0.2		2	A	
Output2						± 5% at Line/Load Voltage Regulation And ± 10 % at Load Transient Voltage Regulation. 20 MHz Bandwidth.
Output Voltage	V_{OUT2}	4.75	5	5.25	V	
Output Ripple Voltage	$V_{RIPPLE2}$			100	mV	
Output Current	I_{OUT2}	0.05		0.5	A	
Total Output Power						
Continuous Output Power	P_{OUT}			26.5	W	
Efficiency						Measured at P_{OUT} 25 °C. Measured at Nominal Input 115 VAC and 230 VAC.
Full Load 115 VAC	$\eta_{115 VAC}$	86			%	
Full Load 230 VAC	$\eta_{230 VAC}$	87			%	
Average efficiency at 25, 50, 75 and 100 % of P_{OUT}	η_{DOE}	85			%	
Environmental						
Conducted EMI		Meets CISPR22B / EN55022B				
Surge (Differential)				±1	kV	1.2/50 μ s Surge, IEC 61000-4-5
Ring Wave (Common Mode)				±4	kV	
Electrical Fast Transient				±4	kV	
ESD – Air Discharge				±16.5	kV	
ESD – Contact Discharge				±8.8	kV	
Ambient Temperature	T_{AMB}	0		40	°C	Free Convection, Sea Level.



3 Schematic

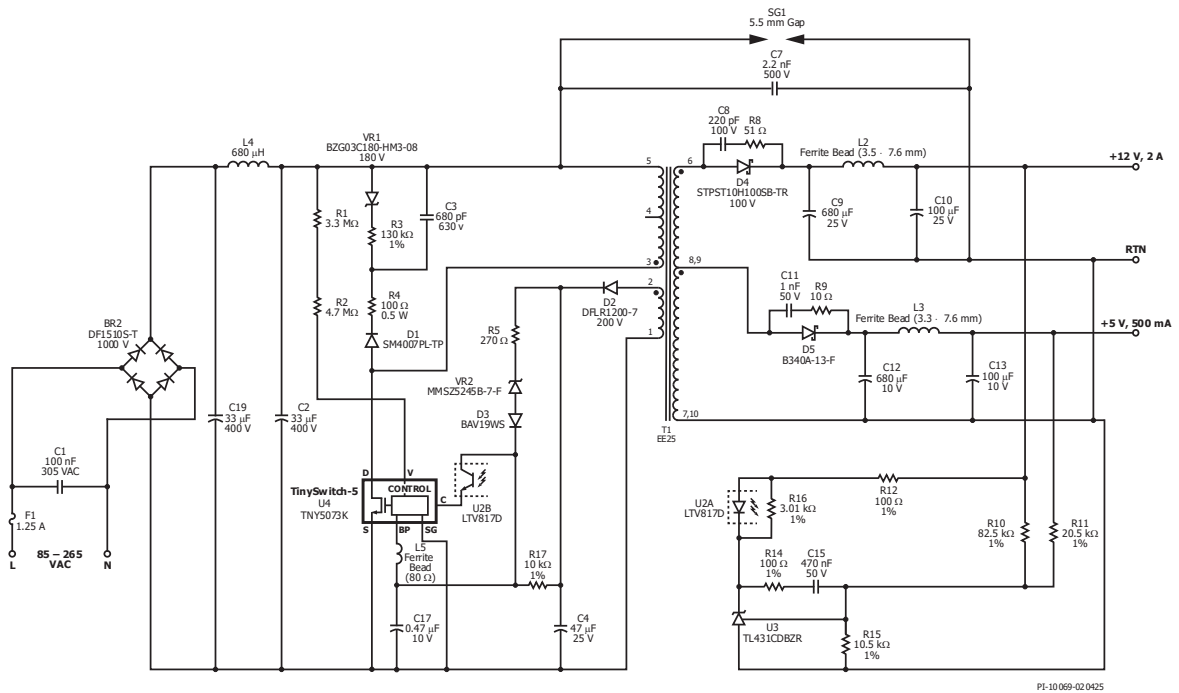

Figure 3 – Schematic.

4 Circuit Description

This power supply employs a TNY5073K off-line switcher operating (U4) in a flyback configuration. IC U4 has an integrated 725 V power MOSFET. It regulates the output by monitoring the analog feedback current at the control input to modulate the variable-off-time variable-current control algorithm.

4.1 Input EMI Filtering and Rectification

Fuse F1 isolates the circuit and provides protection from component failure. Bulk capacitors C19 and C2 together with differential mode choke L4 form an π filter that attenuates both common mode and differential mode conducted EMI. BR2 converts the AC line voltage into the DC voltage seen across bulk capacitors C19 and C2.

4.2 TinySwitch-5 Primary-Side Switcher IC

The TNY5073K device (U4) integrates an oscillator, a controller, start-up circuit and protection circuitry, and a power MOSFET, into a single IC. One side of the power transformer (T1) primary winding is connected to the positive side of the bulk capacitors C19 and C2, and the other side is connected to the DRAIN pin of U4. When the MOSFET turns off, the transformer leakage inductance induces a voltage spike on the drain node. The spike amplitude is limited by an RCDZ clamp network that consists of VR1, D1, R3, R4, and C3. Resistor R4 and capacitor C3 damp high frequency ringing and improve EMI. Y capacitor C7, connected between the primary and secondary sides helps reduce EMI.

The power supply output voltage is sensed on the secondary side by shunt regulator U3 and provides a feedback signal to the primary side through optocoupler U2.

Line undervoltage and overvoltage is monitored by the current supplied from resistors R1 and R2 to the V pin. R5, D3, and VR2 are used for output overvoltage protection. An increase in output voltage causes an increase in the bias winding voltage applied to VR2. An applied voltage above the breakdown of VR2 will cause current to be injected into the BP pin causing the U4 to enter auto-restart.

Bypass capacitor C17 provides energy for IC U4 and is placed as physically close as possible to U4. At start-up, this capacitor is charged through the DRAIN (D) pin. Once it is charged, U4 begins to switch. Capacitor C4 stores sufficient energy to ensure the TinySwitch-5 IC is powered until the output reaches regulation. After start-up, the bias winding delivers current via diode D2 and R17 to charge capacitor C4 which in turn powers the controller. Resistor R17 is used to set the typical bias current for U4. Ferrite bead L5 minimizes the noise coming to the BP Pin and should be placed as close as possible to the IC.

4.3 Output Rectification

Schottky diode D4 rectifies the 12 V secondary winding output of T1. The output voltage is filtered by C9, L2, and C10. Resistor R8 and capacitor C8 snub the voltage spike caused



by the commutation of D4. Schottky diode D5 rectifies the 5 V secondary winding output of T1. The output voltage is filtered by C12, L3, and C13. Resistor R9 and capacitor C11 absorb the noise caused by the commutation of D5. A low voltage rating diode may be used for D4 and D5 due to the flexibility of a higher turns ratio (higher VOR) made possible by the voltage rating of the primary switch (725 V). This also further improves efficiency due to the low forward voltage drop (VF) of the lower voltage diode.

4.4 Output Rectification

The reference IC, U3 (TL431CDBZR), is used to set the output voltage programmed via the feedback resistor divider R10, R11 and R15. The TL431CDBZR varies its cathode voltage to keep the input voltage constant (equal to 2.50 V, $\pm 2.2\%$). As the cathode voltage changes, the current through the optocoupler LED and transistor within U2 changes. R12, R14 and C15 provide stable operation, while resistor R16 maintains minimum bias to U3.



5 PCB Layout

5.1 PCB Specification

- Layer: 1
- Board Thickness: 1.6 mm.
- Copper Thickness: 2 oz.
- Material: FR-4

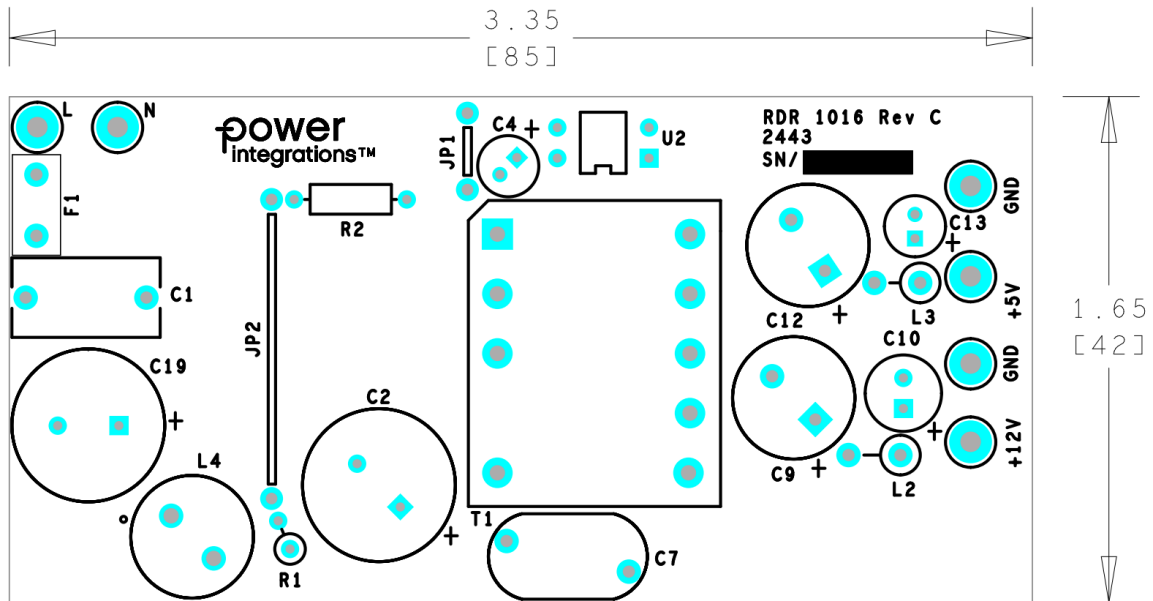

Figure 4 – Printed Circuit Layout, Top.

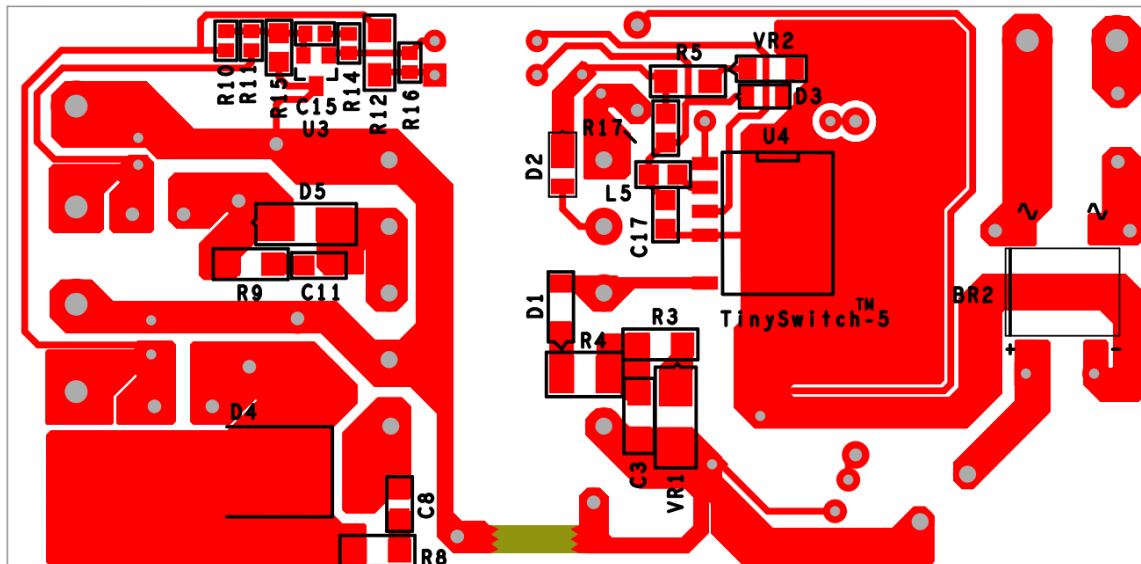

Figure 5 – Printed Circuit Layout, Bottom.

6 Bill of Materials

6.1 Electrical BOM

Item	Qty.	Ref Des	Description	Mfr. Part Number	Manufacturer
1	1	BR2	Bridge Rectifier, Single Phase, Standard, 1 kV, Surface Mount (DF-S), DF-S,4-SMD	DF1510S-T	Diodes Incorporated
2	1	C1	100 nF, 305 VAC, Film, X2	B32921C3104M	Epcos
3	2	C2 C19	33 uF, 400 V, Electrolytic, Very Low ESR, 18 mOhm, (12.5 x 25)	EKMG401ELL330MK25S	Nippon Chemi-Con
			33 uF, 400 V, Electrolytic, (12.5 x 20)	EKMG401ELL330MK20S	Nippon Chemi-Con
4	1	C3	680 pF, 630 V, Ceramic, X7R, 1206	C1206C681KBRAC7800	Kemet
5	1	C4	47 uF, 25 V, Electrolytic, Very Low ESR, 300 mOhm, (5 x 11)	EKZE250ELL470ME11D	Nippon Chemi-Con
			47 uF, 25 V, Electrolytic, Very Low ESR, 350 mOhm, (5 x 11)	860080472002	Würth Elektronik
6	1	C7	2200 PF,±20%, 500 VAC (Y1),760VAC (X1), Ceramic, Y5U (E), RADIAL	440LD22-R	Vishay
7	1	C8	220 pF, 100 V, Ceramic, X7R, 0805	08051C221KAT2A	AVX
8	1	C9	680 uF, 25 V, Electrolytic, Very Low ESR, 32 mOhm, (10 x 16)	EKZH250EC3681MJ16S	Nippon Chemi-Con
			680 uF, 25 V, Electrolytic, Very Low ESR, 50 mOhm, (10 x 20)	860040475009	Würth Elektronik
9	1	C10	100 uF, 25 V, Electrolytic, Very Low ESR, 130 mOhm, (6.3 x 11)	EKZE250ELL101MF11D	Nippon Chemi-Con
			100 uF, 25 V, Electrolytic, Very Low ESR, 150 mOhm, (6.3 x 11)	860080473006	Würth Elektronik
10	1	C11	1 nF, 50 V, Ceramic, X7R, 0805	08055C102KAT2A	AVX Corp
11	1	C12	680 uF, 10 V, Electrolytic, Very Low ESR, 53 mOhm, (10 x 12.5)	EKZE100ELL681MJC5S	Nippon Chemi-Con
			680 uF, 10 V, Electrolytic, Very Low ESR, 85 mOhm, (10 x 12.5)	860040275006	Würth Elektronik
12	1	C13	100 uF, 10 V, Electrolytic, Very Low ESR, 300 mOhm, (5 x 11)	EKZE100ELL101ME11D	Nippon Chemi-Con
			100 uF, 10 V, Electrolytic, Very Low ESR, 310 mOhm, (5 x 11)	860080272003	Würth Elektronik
13	1	C15	0.47 uF, ±10%, 50 V, Ceramic Capacitor X7R, 0603 (1608 Metric)	CGA3E3X7R1H474K080AB	TDK Corporation
14	1	C17	0.47 uF, ±10%, 25 V, Ceramic Capacitor, X7R, 0805 (2012 Metric)	CGA4J2X7R1E474K125AA	TDK Corporation
15	1	D1	1000 V, 1 A, Standard Recovery, SOD-123FL	SM4007PL-TP	Micro Commercial Co.
16	1	D2	200 V, 1 A, Rectifier, Glass Passivated, POWERDI123	DFLR1200-7	Diodes Inc
17	1	D3	100 V, 0.2 A, Fast Switching, 50 ns, SOD-323	BAV19WS-7-F	Diode Inc.
18	1	D4	DIODE, SCHOTTKY, 10 A, 100 V, TO-252-3, DPak (2 Leads + Tab), SC-63	STPST10H100SB-TR	STMicroelectronics
19	1	D5	DIODE, SCHOTTKY, 40 V, 3A, SMA, DO-214AA	B340A-13-F	Diodes Incorporated
20	1	F1	FUSE, 1.25 A 250 VAC, Slow, 8.35 mm x 4.0 mm x 7.7 mm	RST 1.25-BULK	Bel Fuse Inc
21	2	L2 L3	3.5 mm x 7.6 mm, 75 Ohms at 25 MHz, 22 AWG hole, Ferrite Bead	2743004112	Fair-Rite
22	1	L4	680 uH Unshielded Wirewound Inductor 900 mA 790 mOhm Max Radial, Vertical Cylinder (Open)	7447480681	Würth Electronics Inc
23	1	L5	80 Ohms at 100 MHz 1 Signal Line Ferrite Bead 0805 (2012 Metric) 300 mA 300 mOhm	EBMS201209K800	Max Echo
24	1	R1	RES, 3.3 M, 5%, 1/4 W, Carbon Film	CFR-25JB-3M3	Yageo
25	1	R2	RES, 4.7 M, 5%, 1/4 W, Carbon Film	CFR-25JB-4M7	Yageo
26	1	R3	RES, 130 k, 1%, 1/4 W, Thick Film, 1206	ERJ-8ENF1303V	Panasonic
27	1	R4	RES, 100 , 5%, 1/2 W, Thick Film, 1210	ERJ-14YJ101U	Panasonic
28	1	R5	RES, 270 R, 5%, 2/3 W, Thick Film, 1206	ERJ-P08J271V	Panasonic
29	1	R8	RES, 51 R, 5%, 2/3 W, Thick Film, 1206	ERJ-P08J510V	Panasonic
30	1	R9	RES, 10 R, 5%, 2/3 W, Thick Film, 1206	ERJ-P08J100V	Panasonic
31	1	R10	RES, 82.5 k, 1%, 1/10 W, Thick Film, 0603	ERJ-3EKF8252V	Panasonic
32	1	R11	RES, 20.5 k, 1%, 1/10 W, Thick Film, 0603	ERJ-3EKF2052V	Panasonic
33	1	R12	RES, 301 R, 1%, 1/4 W, Thick Film, 1206	ERJ-8ENF3010V	Panasonic
34	1	R14	RES, 100 R, ±1%, ±100 ppm/°C, 1/10 W, Thick Film, 0603 (1608 Metric)	CRCW0603100RFKEA	Vishay Dale
35	1	R15	RES, 10.5 k, 1%, 1/8 W, Thick Film, 0805	ERJ-6ENF1052V	Panasonic
36	1	R16	RES, 3.01 k, 1%, 1/10 W, Thick Film, 0603	ERJ-3EKF3011V	Panasonic



37	1	R17	RES, 10.0 k, 1%, 1/8 W, Thick Film, 0805	ERJ-6ENF1002V	Panasonic
38	1	U2	Opto coupler, 35 V, CTR 300-600%, 4-DIP	LTV-817D	Liteon
39	1	U3	IC, Shunt Regulator Adj., 2.495 V, 2.2%, 100mA, 0 °C ~ 70 °C (TA), SOT23-3, TO-236-3, SC-59, SOT-23-3	TL431CDBZR	Texas Instruments
40	1	U4	TinySwitch-5, TNY5073K, eSOP-12P	TNY5073K	Power Integrations
41	1	VR1	Zener Diode 180 V 1.25 W ±6.39% Surface Mount DO-214AC (SMA)	BZG03C180-HM3-08	Vishay Semiconductors
42	1	VR2	DIODE ZENER 15 V 500 MW SOD123	MMSZ5245B-7-F	Diodes, Inc
43	1	T1	Bobbin, EE25, Vertical, 10 pins Transformer	YW-360-02B 750345896	Yih-Hwa Enterprises Würth Elektronik

6.2 Mechanical BOM

Item	Qty.	Ref Des	Description	Mfr. Part Number	Manufacturer
1	1	+5 V	Test Point, RED, THRU-HOLE MOUNT	5010	Keystone
2	1	+12 V	Test Point, YELLOW, THRU-HOLE MOUNT	5014	Keystone
3	3	GND, L	Test Point, BLK, THRU-HOLE MOUNT	5011	Keystone
4	2	JP1 JP2	Wire Jumper, Insulated, 24 AWG, 0.2 in	C2003A-12-02	Gen Cable
5	1	N	Test Point, WHT, THRU-HOLE MOUNT	5012	Keystone



7 Transformer Specification

7.1 Electrical Diagram

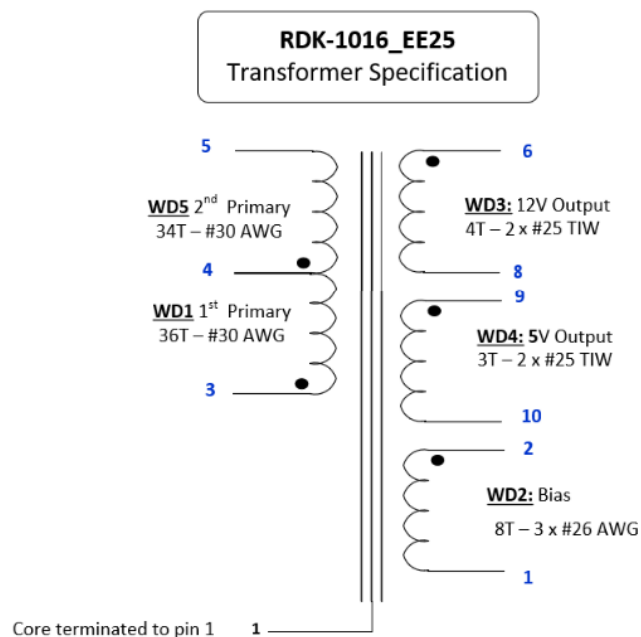

Figure 6 – Transformer Electrical Diagram.

7.2 Electrical Specifications

Parameter	Condition	Spec.
Nominal Primary Inductance	Measured at 1 V pk-pk and 100 kHz frequency, between pin 3 to pin 5, with all other Windings open.	1105.9 uH
Tolerance	Tolerance of Primary Inductance.	±5%
Leakage Inductance	Measured across primary winding with all other windings shorted.	< +3%

7.3 Material List

Item	Description
[1]	Core: EE25 TDK PC40
[2]	Bobbin: EE25, Vertical, 10 pins (Mfg PN: YW-360-02B, Mfg: Yih-Hwa Enterprises)
[3]	Magnet Wire: #30 AWG.
[4]	Magnet Wire: #26 AWG.
[5]	TIW Wire: #25 AWG.
[6]	Polyester Tape: 10.5 mm.
[7]	Polyester Tape: 7 mm.
[8]	Varnish: Dolph BC 359 or Equivalent.
[9]	Bus Wire: uninsulated 26 AWG

7.4 Transformer Build Diagram

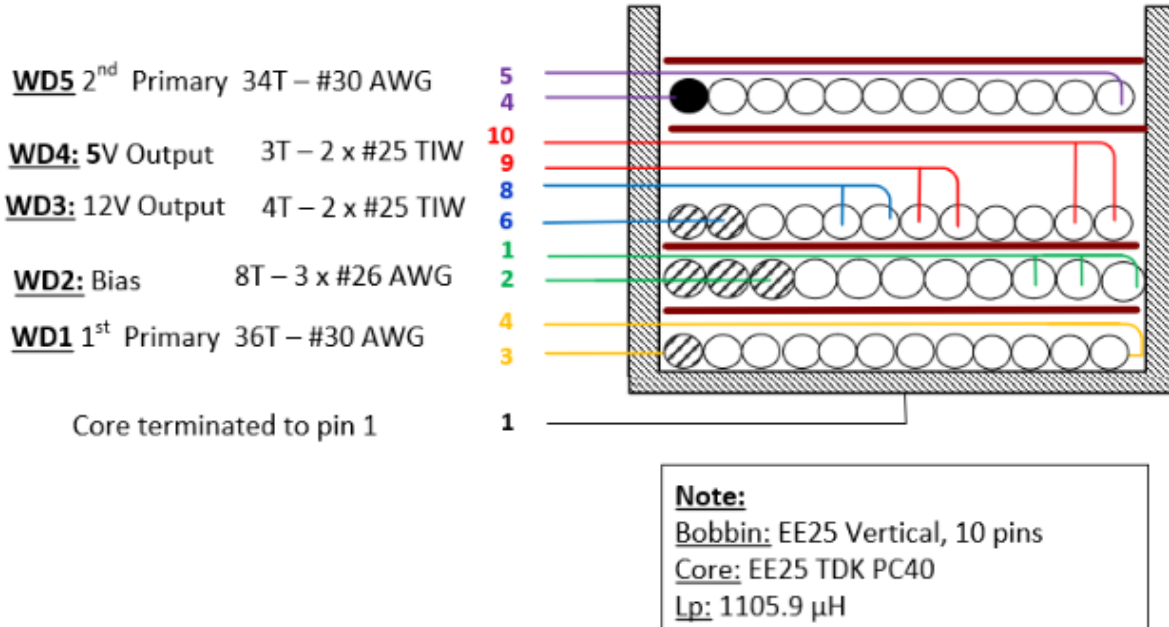

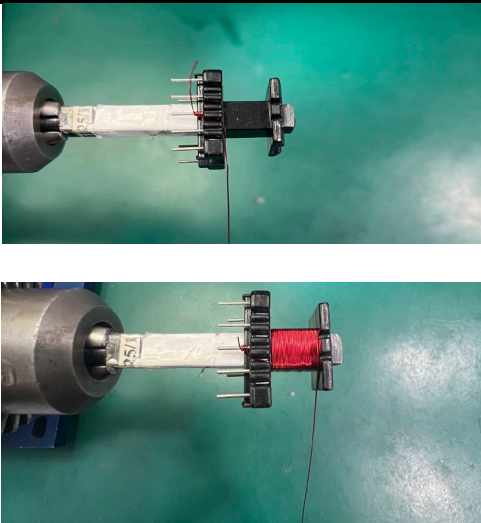
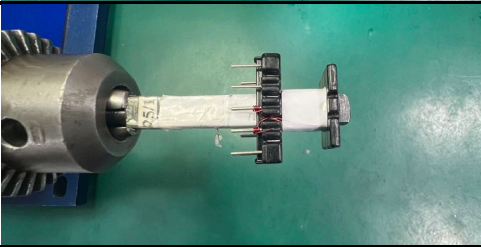
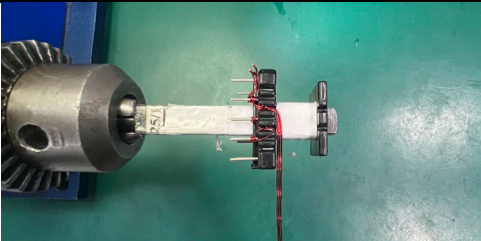

Figure 7 – Transformer Build Diagram.

7.5 Transformer Instructions

Bobbin Preparation	For the purposes of these instructions, Item [2] is oriented on winder such that pin 1 is located on the top right side facing the mandrel. Winding direction is clockwise.
WD1 1st Primary	Start at pin 3, wind 36 turns of wire Item [3] for the 1 st layer. Finish WD1 at pin 4.
Insulation	Use 1 layer of tape Item [6] for insulation.
WD2 Bias	Prepare 3 strands of wire Item [4]. Start 3 strands of wire Item [4] at pin 2, wind 8 turns for 1 layer of winding. Finish WD2 at pin 1.
Insulation	Use 1 layer of tape Item [6] for insulation.
WD3 12 V Output	Prepare 2 strands of wire Item [5]. Start 2 strands of wire Item [5] at pin 6, wind 4 turns for 1 layer of winding. Finish at pin 8.
WD4 5 V Output	Prepare 2 strands of wire Item [5]. Start 2 strands of wire Item [5] at pin 9, wind 3 turns for 1 layer of winding. Finish at pin 10.
Insulation	Use 1 layer of tape Item [6] for insulation.
WD5 2nd Primary	Start at pin 4, wind 34 turns of wire Item [3] for the last layer winding. Finish WD5 at pin 5.
Insulation	Use 1 layer of tape Item [6] for insulation.
Grind Core, Solder and Cut Pin	Use Item [1], Gap Cores to get 1105.9 μH. Solder the wires to the leads of the bobbin and cut Pin 4. Solder a bus wire Item [9], start at pin 1, wrap the bus wire Item [9] around the core Item [1] for 1 revolution.
Finish	Wrap the core with 3 layers of tape Item [7]. Varnish the TRF with item [8].

7.6 Transformer Winding Illustrations

<p>Bobbin Preparation</p>		<p>For the purposes of these instructions, Item [2] is oriented on winder such that pin 1 is located on the top right side facing the mandrel. Winding direction is clockwise.</p>
<p>WD1 1st Primary</p>		<p>Start at pin 3, wind 36 turns of wire Item [3] for the 1st layer. Finish WD1 at pin 4.</p>
<p>Insulation</p>		<p>Use 1 layer of tape Item [6] for insulation.</p>
<p>WD2 Bias</p>		<p>Prepare 3 strands of wire Item [4]. Start 3 strands of wire Item [4] at pin 2, wind 8 turns for 1 layer of winding. Finish WD2 at pin 1.</p>

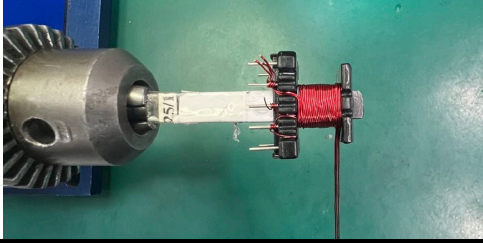
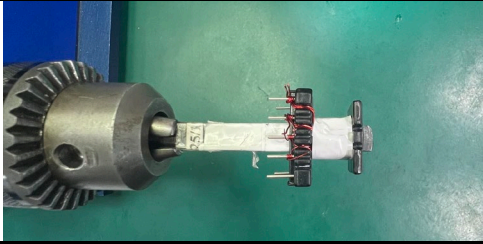
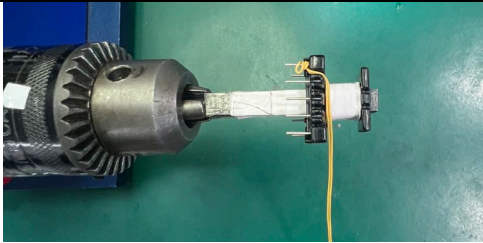
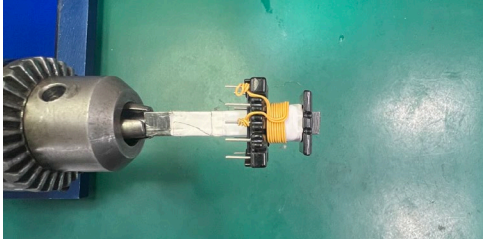
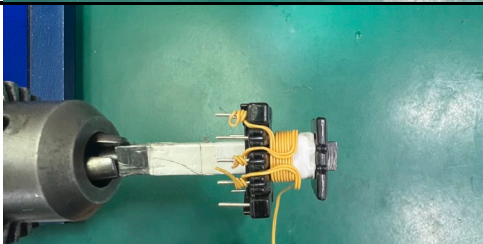
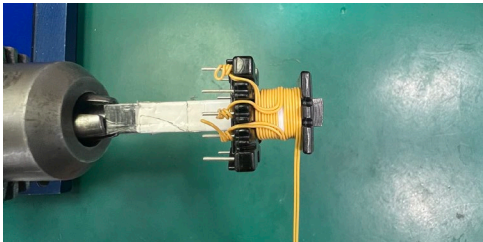
		
<p>Insulation</p>		<p>Use 1 layer of tape Item [6] for insulation.</p>
<p>WD3 12 V Output</p>	 	<p>Prepare 2 strands of wire Item [5]. Start 2 strands of wire Item [5] at pin 6, wind 4 turns for 1 layer of winding. Finish at pin 8.</p>
<p>WD4 5 V Output</p>	 	<p>Prepare 2 strands of wire Item [5]. Start 2 strands of wire Item [5] at pin 9, wind 3 turns for 1 layer of winding. Finish at pin 10.</p>

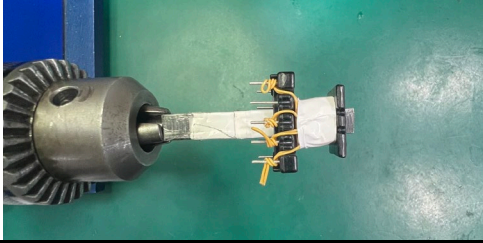
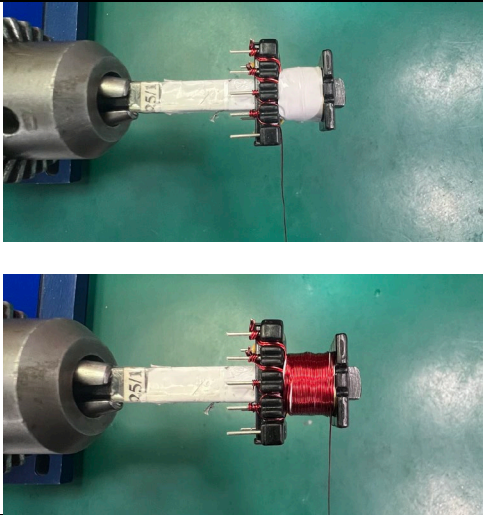
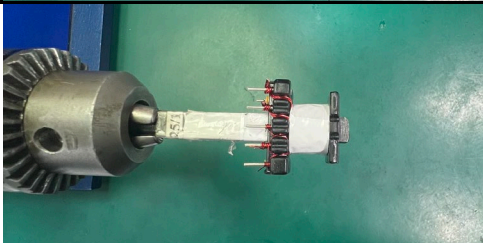
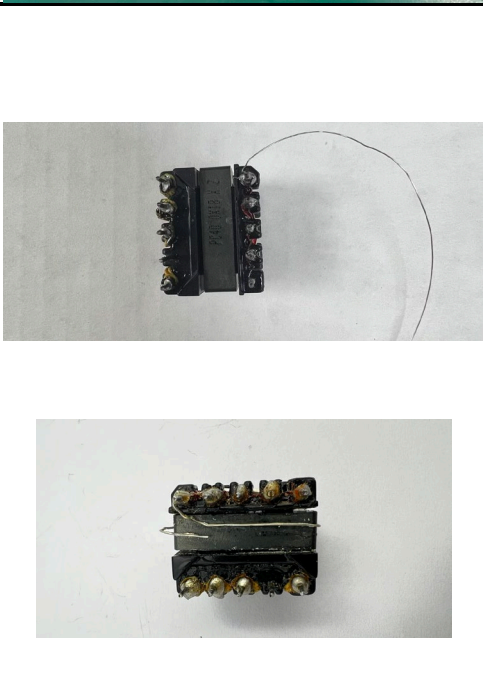
<p>Insulation</p>		<p>Use 1 layer of tape Item [6] for insulation.</p>
<p>WD5 2nd Primary</p>		<p>Start at pin 4, wind 34 turns of wire Item [3] for the last layer winding. Finish WD5 at pin 5.</p>
<p>Insulation</p>		<p>Use 1 layer of tape Item [6] for insulation.</p>
<p>Grind Core, Solder and Cut Pin</p>		<p>Use Item [1], Gap Cores to get 1105.9 μH. Solder the wires to the leads of the bobbin and cut Pin 4. Solder a bus wire Item [9], start at pin 1, wrap the bus wire Item [9] around the core Item [1] for 1 revolution.</p>

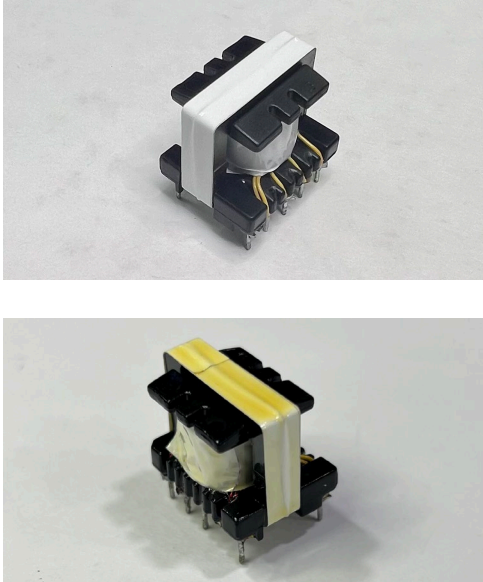
<p>Finish</p>		<p>Wrap the core with 3 layers of tape Item [7]. Varnish the TRF with item [8].</p>
----------------------	---	---

8 Design Spreadsheet

	ACDC_TinySwitch5_Flyback_02 1825; Rev.0.2; Copyright Power Integrations 2025	INPUT	OUTPUT	UNITS	TinySwitch5 Single/Multi Output Flyback Design Spreadsheet
2	APPLICATION VARIABLES				Design Title
3	INPUT_TYPE	AC	AC		Input Type
4	VIN_MIN		85	V	Minimum AC input voltage
5	VIN_MAX		265	V	Maximum AC input voltage
6	VIN_RANGE		85-265	VAC	Range of AC input voltage
7	LINEFREQ		60	Hz	AC Input voltage frequency
8	CAP_INPUT	66.0	66.0	uF	Input capacitor
9	VOUT		12.00	V	Output voltage at the board
10	IOUT	2.208	2.208	A	Output current
11	POUT		26.50	W	Output power
12	EFFICIENCY		0.87		AC-DC efficiency estimate at full load given that the converter is switching at the valley of the rectified minimum input AC voltage
13	FACTOR_Z		0.50		Z-factor estimate
14	ENCLOSURE	OPEN FRAME	OPEN FRAME		Power supply enclosure
15					
16					
17					
18	PRIMARY CONTROLLER SELECTION				
19	DEVICE_SERIES	TNY507 3	TNY5073		Generic device code
20	PACKAGE_DEVICE	eSOP	eSOP		Device Package
21	DEVICE_CODE		TNY5073K		Actual device code
22	POUT_MAX		30	W	Power capability of the device based on thermal performance
23	RDSON_100DEG		6.38	Ω	Primary switch on time drain resistance at 100 degC
24	ILIMIT_MIN		0.741	A	Minimum current limit of the primary switch
25	ILIMIT_TYP		0.805	A	Typical current limit of the primary switch



26	ILIMIT_MAX		0.869	A	Maximum current limit of the primary switch
27	VDRAIN_BREAKDOWN		725	V	Device breakdown voltage
28	VDRAIN_ON_PRSW		2.02	V	Primary switch on time drain voltage
29	VDRAIN_OFF_PRSW		528.4	V	Peak drain voltage on the primary switch during turn-off. A 30V leakage spike voltage is assumed
30					
31					
32					
33	WORST CASE ELECTRICAL PARAMETERS				
34	FSWITCHING_MAX	119300	119300	Hz	Maximum switching frequency at full load and valley of the rectified minimum AC input voltage.
35	VOR	125.0	125.0	V	Secondary voltage reflected to the primary when the primary switch turns off
36	VMIN		92.12	V	Valley of the minimum input AC voltage at full load
37	KP		0.55		Measure of continuous/discontinuous mode of operation
38	MODE_OPERATION		CCM		Mode of operation
39	DUTYCYCLE		0.581		Primary switch duty cycle
40	TIME_ON		13.50	us	Primary switch on-time
41	TIME_ON_AT_FSWITCHING_MAX		4.87	us	Primary switch on-time at FSWITCHING_MAX
42	TIME_OFF		3.51	us	Primary switch off-time at 85VAC, 26.496W, and 119300Hz.
43	LPRIMARY_MIN		1050.6	uH	Minimum primary inductance
44	LPRIMARY_TYP		1105.9	uH	Typical primary inductance



45	LPRIMARY_TOL	5.0	5.0	%	Primary inductance tolerance
46	LPRIMARY_MAX		1161.2	uH	Maximum primary inductance
47					
48	PRIMARY CURRENT				
49	IPEAK_PRIMARY		0.850	A	Primary switch peak current
50	IPEDESTAL_PRIMARY		0.340	A	Primary switch current pedestal
51	IAVG_PRIMARY		0.316	A	Primary switch average current
52	IRIPPLE_PRIMARY		0.613	A	Primary switch ripple current
53	IRMS_PRIMARY		0.436	A	Primary switch RMS current
54					
55	SECONDARY CURRENT				
56	IPEAK_SECONDARY		8.502	A	Secondary winding peak current
57	IPEDESTAL_SECONDARY		3.397	A	Secondary winding current pedestal
58	IRMS_SECONDARY		3.701	A	Secondary winding RMS current
59					
60					
61					
62	TRANSFORMER CONSTRUCTION PARAMETERS				
63	CORE SELECTION				
64	CORE	EE25	EE25		Core selection. Refer to the 'Transformer Construction' tab to see the detailed report
65	CORE CODE		PC40EE25/19-Z		Core code
66	AE		40.00	mm ²	Core cross sectional area
67	LE		48.70	mm	Core magnetic path length
68	AL		2000	nH/turns ²	Ungapped core effective inductance
69	VE		1950.0	mm ³	Core volume
70	BOBBIN		BE25-118CPFR		Bobbin
71	AW		44.10	mm ²	Window area of the bobbin



72	BW		9.80	mm	Bobbin width
73	MARGIN		0.0	mm	Safety margin width (Half the primary to secondary creepage distance)
74					
75	PRIMARY WINDING				
76	NPRIMARY		70		Primary turns
77	BPEAK		3720	Gauss	Peak flux density
78	BMAX		3493	Gauss	Maximum flux density
79	BAC		1238	Gauss	AC flux density (0.5 x Peak to Peak)
80	ALG		226	nH/turns ²	Typical gapped core effective inductance
81	LG		0.198	mm	Core gap length
82					
83	PRIMARY BIAS WINDING				
84	NBIAS_PRIMARY		8	turns	Primary bias winding number of turns
85					
86	SECONDARY WINDING				
87	NSECONDARY	7	7	turns	Secondary winding number of turns
88					
89	SECONDARY BIAS WINDING				
90	NBIAS_SECONDARY		NA	turns	Secondary bias winding number of turns
91					
92					
93					
94	PRIMARY COMPONENTS SELECTION				
95	LINE UNDERVOLTAGE				
96	BROWN-IN REQUIRED		76.08	V	Required AC RMS/DC line voltage brown-in threshold
97	RLS		8.04	MΩ	Connect two 4.02 MΩ resistors to the V-pin for the required UV/OV threshold
98	BROWN-IN ACTUAL		63.5 - 78.6	V	Actual AC RMS/DC brown-in range
99	BROWN-OUT ACTUAL		55 - 67.9	V	Actual AC RMS/DC brown-out range
100					
101	LINE OVERVOLTAGE				



102	OVERVOLTAGE_LINE		285.4 - 355.2	V	Actual AC RMS/DC line over-voltage range
103					
104	PRIMARY BIAS DIODE				
105	VBIAS_PRIMARY		12.0	V	Rectified primary bias voltage
106	VF_BIAS_PRIMARY		0.70	V	Bias winding diode forward drop
107	VREVERSE_BIASDIODE_PRIMARY		56.38	V	Bias diode reverse voltage (not accounting parasitic voltage ring)
108	CBIAS_PRIMARY		47	uF	Bias winding rectification capacitor
109	CBP		0.47	uF	BP pin capacitor
110					
111					
112					
113	SECONDARY COMPONENTS				
114	VREF_REG	2.50	2.50	V	Reference voltage of the feedback
115	RFB_UPPER		38.30	k Ω	Upper feedback resistor (connected to the first output voltage)
116	RFB_LOWER		10.00	k Ω	Lower feedback resistor
117					
118	SECONDARY BIAS DIODE				
119	USE_SECONDARY_BIAS	AUTO	NO		Use secondary bias winding for the design
120	VBIAS_SECONDARY		NA	V	Rectified secondary bias voltage
121	VF_BIAS_SECONDARY		NA	V	Bias winding diode forward drop
122	VREVERSE_BIASDIODE_SECONDARY		NA	V	Bias diode reverse voltage (not accounting parasitic voltage ring)
123	CBIAS_SECONDARY		NA	uF	Bias winding rectification capacitor
124					
125					
126	MULTIPLE OUTPUT PARAMETERS				
127	OUTPUT 1				
128	VOUT1		12.00	V	Output 1 voltage
129	IOUT1	2.00	2.00	A	Output 1 current



130	POUT1		24.00	W	Output 1 power
131	VD1	0.60	0.60	V	Forward voltage drop of diode for output 1
132	NS1		7.00	turns	Number of turns for output 1
133	ISPEAK1		8.50	A	Instantaneous peak value of the secondary current for output 1
134	ISRMS1		3.353	A	Root-mean-squared value of the secondary current for output 1
135	ISRIPPLE1		2.691	A	Current ripple on the secondary waveform for output 1
136	PIV1_CALCULATED		58.96	V	Computed peak inverse voltage stress on the diode for output 1
137	OUTPUT_RECTIFIER1	AUTO	SB560		Recommended diode for output 1.
138	PIV1_RATING		60.00	V	Peak inverse voltage rating on the diode for output 1
139	TRR1		0.00	ns	Reverse recovery time of the diode for output 1
140	IFM1		5.00	A	Maximum forward continuous current of the diode for output 1
141	PLOSS_DIODE1		1.93	W	Maximum diode power loss for output 1
142					
143	OUTPUT 2				
144	VOUT2	5.00	5.00	V	Output 2 voltage
145	IOUT2	0.500	0.500	A	Output 2 current
146	POUT2		2.50	W	Output 2 power
147	VD2	0.40	0.40	V	Forward voltage drop of diode for output 2
148	NS2		3.00	turns	Number of turns for output 2
149	ISPEAK2		19.84	A	Instantaneous peak value of the secondary current for output 1
150	ISRMS2		0.838	A	Root mean squared value of the



					secondary current for output 2
151	ISRIPPLE2		0.673	A	Current ripple on the secondary waveform for output 2
152	PIV2		25.10	V	Computed peak inverse voltage stress on the diode for output 2
153	OUTPUT_RECTIFIER2	AUTO	1N5821		Recommended diode for output 2.
154	PIV2_RATING		30.00	V	Peak inverse voltage rating on the diode for output 2
155	TRR2		0.00	ns	Reverse recovery time of the diode for output 2
156	IFM2		3.00	A	Maximum forward continuous current of the diode for output 2
157	PLOSS_DIODE2		0.32	W	Maximum diode power loss for output 2
158					
159	OUTPUT 3				
160	VOUT3		0.00	V	Output 3 voltage
161	IOUT3		0.000	A	Output 3 current
162	POUT3		0.00	W	Output 3 power
163	VD3		N/A	V	Forward voltage drop of diode for output 3
164	NS3		N/A	turns	Number of turns for output 3
165	ISPEAK3		N/A	A	Instantaneous peak value of the secondary current for output 1
166	ISRMS3		N/A	A	Root mean squared value of the secondary current for output 3
167	ISRIPPLE3		N/A	A	Current ripple on the secondary waveform for output 3
168	PIV3		N/A	V	Computed peak inverse voltage stress on the diode for output 3
169	OUTPUT_RECTIFIER3	AUTO	N/A		Recommended diode for output 3.



170	PIV3_RATING		N/A	V	Peak inverse voltage rating on the diode for output 3
171	TRR3		N/A	ns	Reverse recovery time of the diode for output 3
172	IFM3		N/A	A	Maximum forward continuous current of the diode for output 3
173	PLOSS_DIODE3		N/A	W	Maximum diode power loss for output 2
174					
175	PO_TOTAL		26.50	W	The total power of all outputs does not add up to the total power of the design

9 Performance Data

9.1 Full Load Efficiency vs. Line

Test Condition: The board was soaked for 15 minutes at each line voltage before taking measurements.

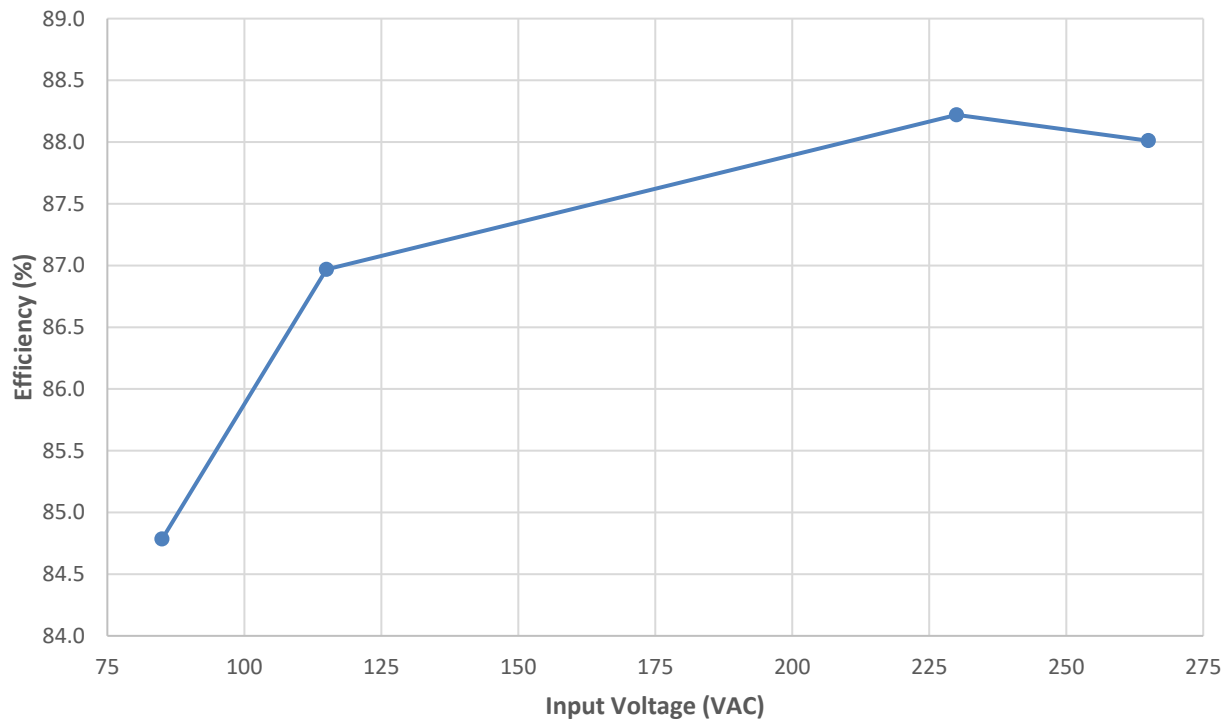

Figure 8 – Efficiency vs. Input Voltage.

VAC	Freq	V _{IN}	I _{IN}	P _{IN}	V _{OUT}	I _{OUT}	P _{OUT}	V _{REG}	V _{OUT}	I _{OUT}	P _{OUT}	V _{REG}	Efficiency
(RMS)	(Hz)	(RMS)	(mA)	(W)	(V)	(A)	(W)	(%)	(V)	(A)	(W)	(%)	(%)
85	60	85	669	30.9	11.9	2	23.7	-1.15	4.98	0.5	2.49	-0.34	84.8
115	60	115	540	30.1	11.9	2	23.7	-1.21	4.98	0.5	2.49	-0.32	87
230	50	230	349	29.7	11.9	2	23.7	-1.19	4.99	0.5	2.50	-0.12	88.2
265	50	265	311	29.8	11.9	2	23.7	-1.23	4.99	0.5	2.50	-0.14	88

9.2 Line Regulation

Test Condition: The board was soaked for 15 minutes at each line voltage before taking measurements.

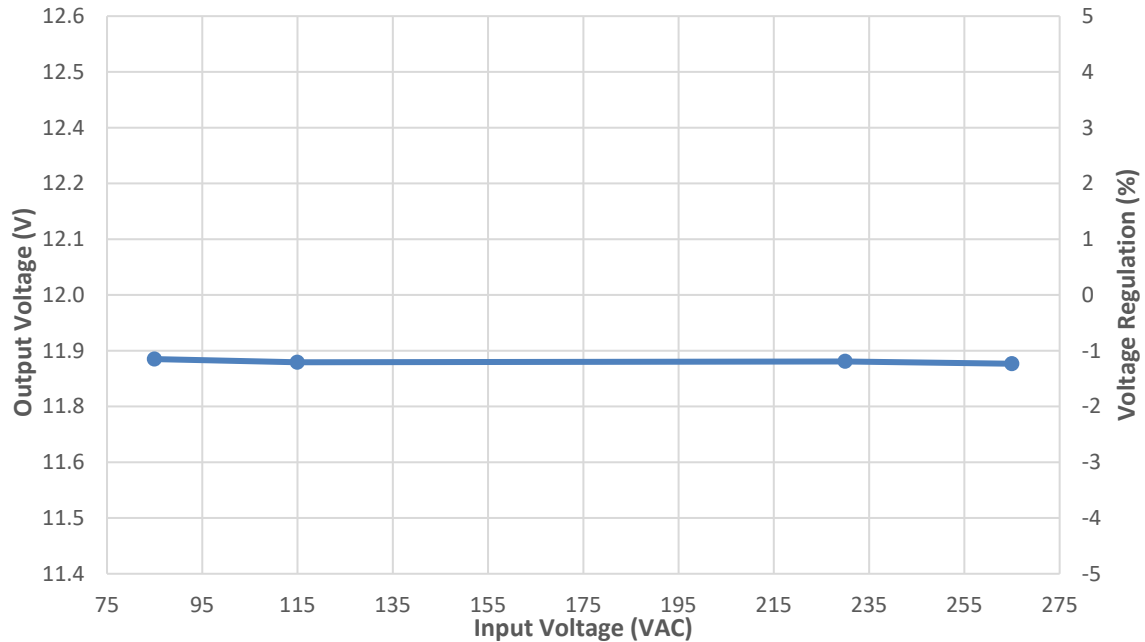

Figure 9 – 12 Output Voltage vs. Line Voltage.

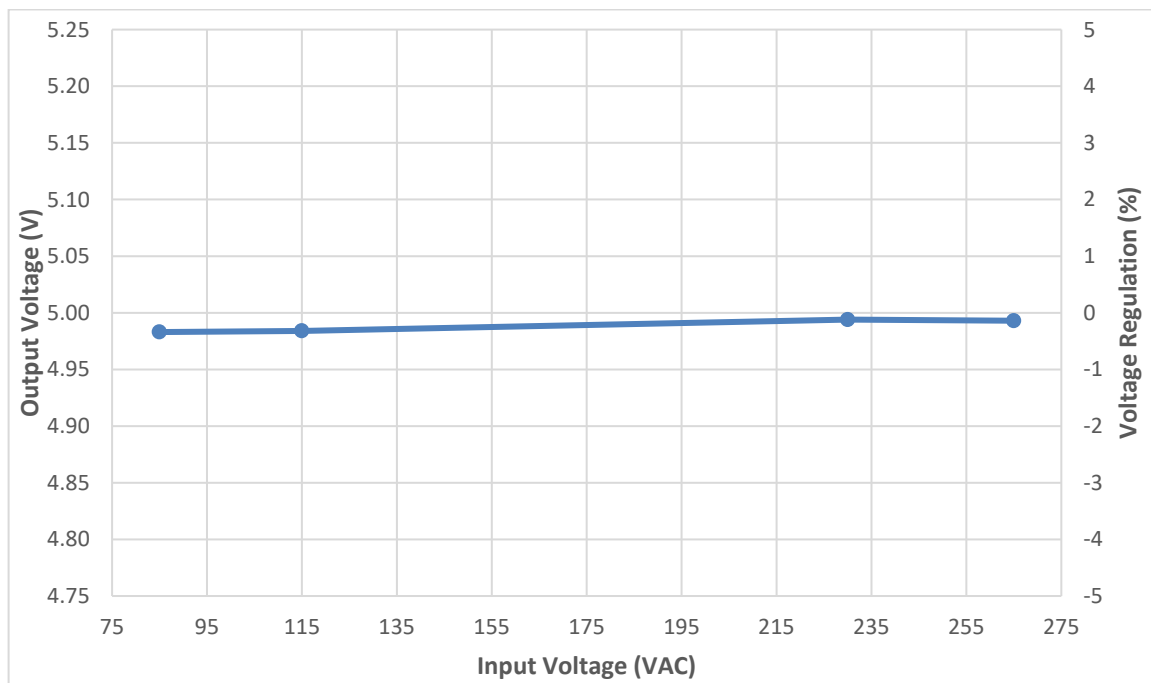

Figure 10 – 5 Output Voltage vs. Line Voltage.

9.3 Efficiency vs. Load

Test Condition: The board was soaked for 15 minutes at each line voltage, and the signal was integrated for 10 seconds to derive each measurement.

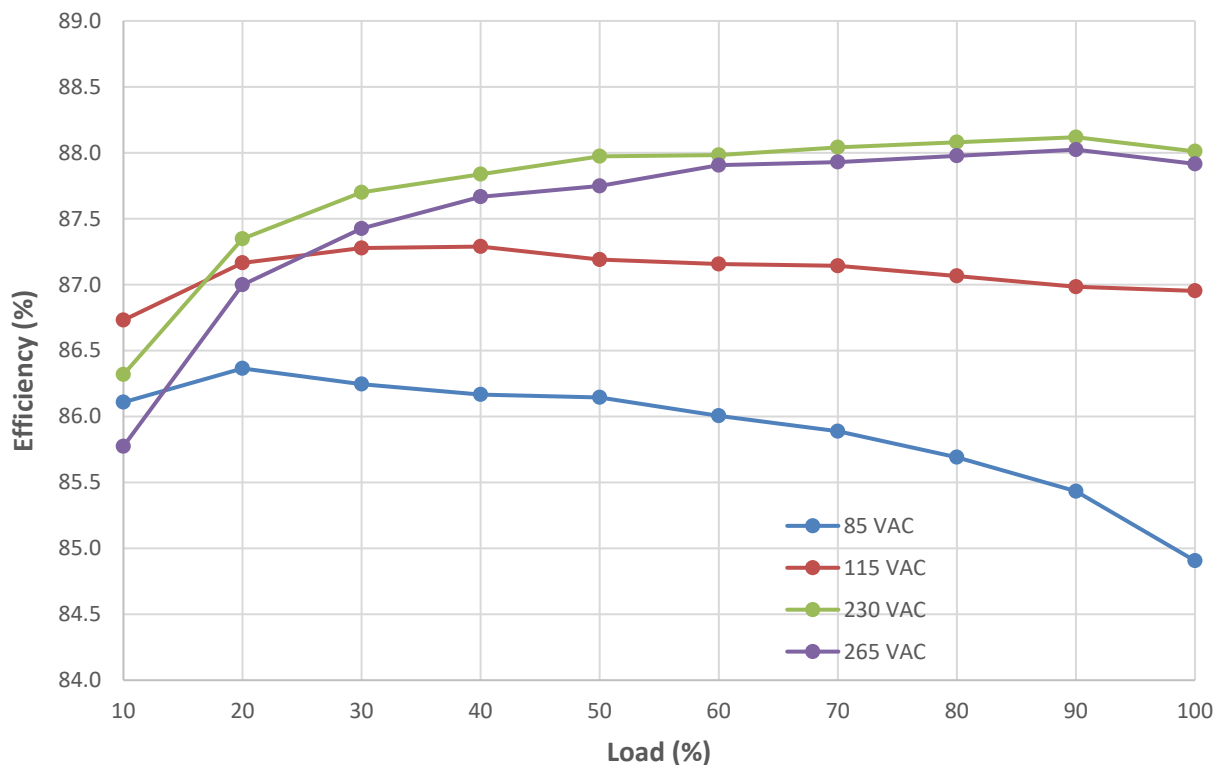

Figure 11 – Efficiency vs. Percentage Load.

VAC	Freq	V _{IN}	I _{IN}	P _{IN}	12 V _{OUT}	I _{OUT}	P _{OUT}	V _{REG}	5 V _{OUT}	I _{OUT}	P _{OUT}	V _{REG}	Efficiency
(RMS)	(Hz)	(RMS)	(mA)	(W)	(V)	(A)	(W)	(%)	(V)	(A)	(W)	(%)	(%)
85	60	85	664	30.7	11.8	2	23.60	-1.63	4.95	0.5	2.47	-1.08	84.9
85	60	85	605	27.5	11.8	1.8	21.24	-1.63	4.95	0.45	2.23	-0.94	85.4
85	60	85	547	24.4	11.8	1.6	18.91	-1.50	4.96	0.4	1.99	-0.72	85.7
85	60	85	488	21.3	11.8	1.4	16.57	-1.32	4.98	0.35	1.74	-0.48	85.9
85	60	85	431	18.3	11.9	1.2	14.21	-1.25	4.98	0.3	1.49	-0.42	86
85	60	85	375	15.2	11.9	1.0	11.85	-1.23	4.98	0.25	1.25	-0.38	86.1
85	60	85	319	12.2	11.9	0.8	9.48	-1.20	4.98	0.2	1.00	-0.36	86.2
85	60	85	257	9.11	11.9	0.6	7.11	-1.18	4.98	0.15	0.75	-0.36	86.2
85	60	85	178	6.07	11.9	0.4	4.74	-1.15	4.98	0.1	0.50	-0.34	86.4
85	60	85	94	3.04	11.9	0.2	2.37	-1.12	4.98	0.05	0.25	-0.32	86.1

VAC	Freq	V _{IN}	I _{IN}	P _{IN}	12 V _{OUT}	I _{OUT}	P _{OUT}	V _{REG}	5 V _{OUT}	I _{OUT}	P _{OUT}	V _{REG}	Efficiency
(RMS)	(Hz)	(RMS)	(mA)	(W)	(V)	(A)	(W)	(%)	(V)	(A)	(W)	(%)	(%)
115	60	115	536	29.9	11.8	2	23.6	-1.81	4.95	0.5	2.48	-0.94	87
115	60	115	496	27	11.8	1.8	21.2	-1.61	4.96	0.45	2.23	-0.74	87
115	60	115	456	24	11.8	1.6	18.9	-1.53	4.97	0.4	1.99	-0.64	87
115	60	115	416	21	11.8	1.4	16.6	-1.34	4.98	0.35	1.74	-0.40	87.1
115	60	115	373	18	11.8	1.2	14.2	-1.31	4.98	0.3	1.49	-0.38	87.2
115	60	115	318	15	11.9	1.0	11.8	-1.28	4.98	0.25	1.25	-0.36	87.2
115	60	115	259	12	11.9	0.8	9.48	-1.25	4.98	0.2	1.00	-0.34	87.3
115	60	115	199	9	11.9	0.6	7.11	-1.23	4.98	0.15	0.75	-0.34	87.3
115	60	115	138	6.01	11.9	0.4	4.74	-1.20	4.98	0.1	0.50	-0.32	87.2
115	60	115	74.2	3.02	11.9	0.2	2.37	-1.17	4.99	0.05	0.25	-0.30	86.7

VAC	Freq	V _{IN}	I _{IN}	P _{IN}	12 V _{OUT}	I _{OUT}	P _{OUT}	V _{REG}	5 V _{OUT}	I _{OUT}	P _{OUT}	V _{REG}	Efficiency
(RMS)	(Hz)	(RMS)	(mA)	(W)	(V)	(A)	(W)	(%)	(V)	(A)	(W)	(%)	(%)
230	50	230	347	29.5	11.8	2	23.5	-1.99	4.95	0.5	2.48	-0.92	88
230	50	230	316	27	11.8	1.8	21.3	-1.57	4.98	0.45	2.24	-0.46	88.1
230	50	230	284	24	11.8	1.6	18.9	-1.53	4.98	0.4	1.99	-0.40	88
230	50	230	252	21	11.8	1.4	16.5	-1.47	4.98	0.35	1.74	-0.38	88
230	50	230	219	18	11.8	1.2	14.2	-1.44	4.98	0.3	1.49	-0.34	88
230	50	230	186	15	11.8	1.0	11.8	-1.41	4.98	0.25	1.25	-0.32	88
230	50	230	153	11.9	11.8	0.8	9.47	-1.37	4.99	0.2	1.00	-0.30	87.8
230	50	230	118	8.95	11.8	0.6	7.10	-1.34	4.99	0.15	0.75	-0.28	87.7
230	50	230	81.9	5.99	11.8	0.4	4.73	-1.32	4.99	0.1	0.50	-0.26	87.4
230	50	230	47	3.03	11.9	0.2	2.37	-1.28	4.99	0.05	0.25	-0.24	86.3



VAC	Freq	V _{IN}	I _{IN}	P _{IN}	12 V _{OUT}	I _{OUT}	P _{OUT}	V _{REG}	5 V _{OUT}	I _{OUT}	P _{OUT}	V _{REG}	Efficiency
(RMS)	(Hz)	(RMS)	(mA)	(W)	(V)	(A)	(W)	(%)	(V)	(A)	(W)	(%)	(%)
265	50	265	309	29.6	11.8	2	23.5	-2.04	4.96	0.5	2.48	-0.90	87.9
265	50	265	282	26.7	11.8	1.8	21.3	-1.61	4.98	0.45	2.24	-0.44	88
265	50	265	253	23.7	11.8	1.6	18.9	-1.56	4.98	0.4	1.99	-0.40	88
265	50	265	225	20.8	11.8	1.4	16.5	-1.52	4.98	0.35	1.74	-0.36	87.9
265	50	265	196	17.8	11.8	1.2	14.2	-1.47	4.98	0.3	1.49	-0.34	87.9
265	50	265	167	14.9	11.8	1.0	11.8	-1.47	4.98	0.25	1.25	-0.32	87.8
265	50	265	137	11.9	11.8	0.8	9.46	-1.41	4.99	0.2	1.00	-0.28	87.7
265	50	265	104	8.98	11.8	0.6	7.10	-1.37	4.99	0.15	0.75	-0.26	87.4
265	50	265	74.2	6.01	11.8	0.4	4.73	-1.34	4.99	0.1	0.50	-0.24	87
265	50	265	43.5	3.05	11.8	0.2	2.37	-1.31	4.99	0.05	0.25	-0.22	85.8



9.4 Load Regulation

Test Condition: The board was soaked for 15 minutes at each line voltage, and the signal was integrated for 10 seconds to derive each measurement.

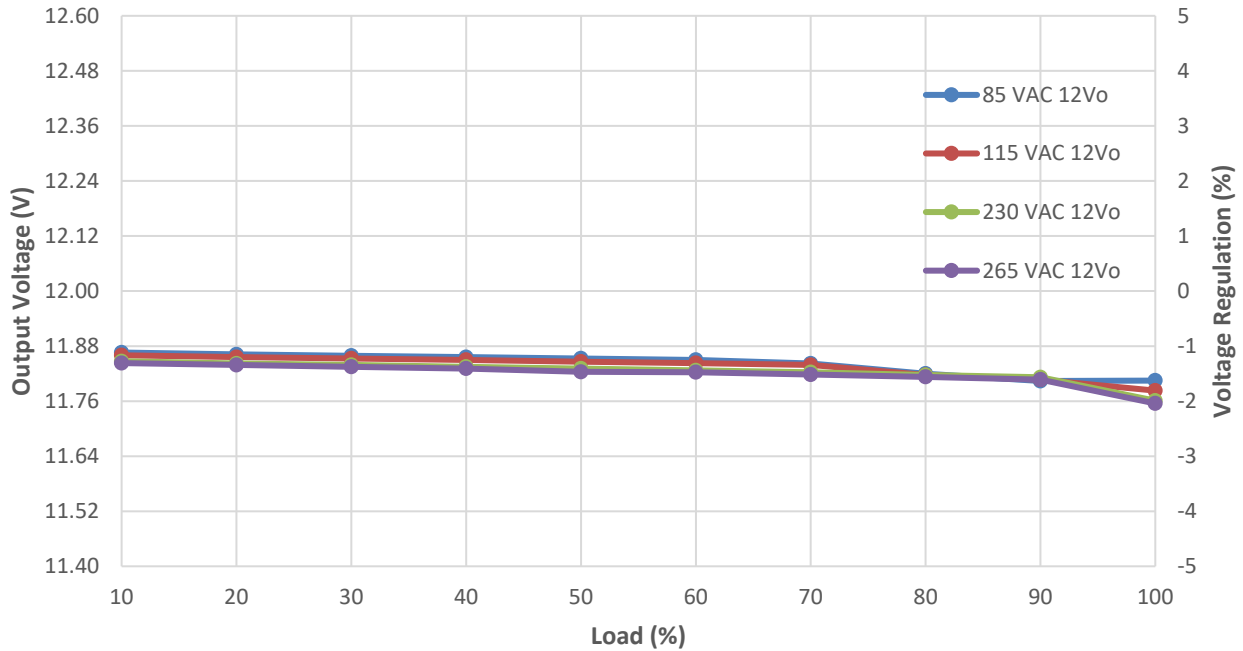

Figure 12 – 12 Output Voltage vs. Percent Load.

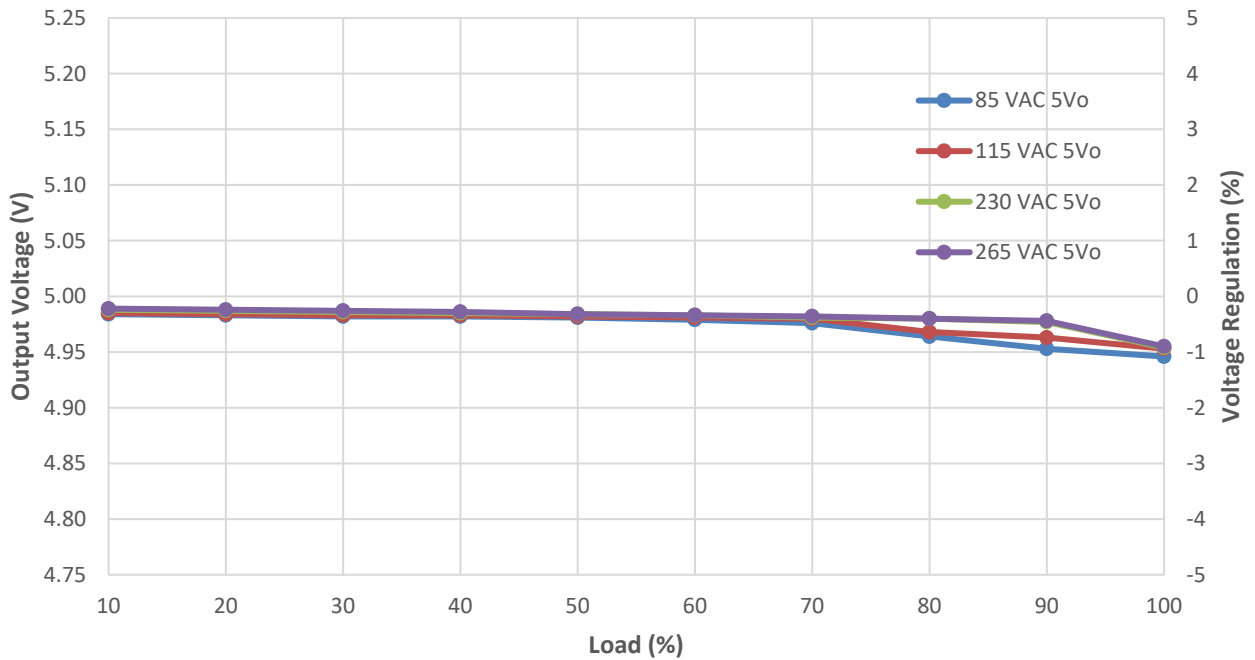

Figure 13 – 5 Output Voltage vs. Percent Load.



9.5 Average and 10% Efficiency

9.5.1 Average and 10% Efficiency at 115 VAC

Load	P _{IN}	12 V _{OUT} at PCB	I _{OUT}	P _{OUT}	5 V _{OUT} at PCB	I _{OUT}	P _{OUT}	Efficiency at PCB	Average Efficiency	DOE6 Limit
(%)	(W)	(V _{DC})	(A)	(W)	(V _{DC})	(A)	(W)	(%)	(%)	(%)
100	30.3	11.7	2	23.4	4.90	0.5	2.45	85.1	85.9	80.7
75	22.8	11.8	1.5	17.7	4.93	0.375	1.85	85.7		
50	15.3	11.8	1	11.8	4.96	0.25	1.24	86.2		
25	7.58	11.9	0.5	5.95	4.92	0.125	0.61	86.6		
10	3.04	11.9	0.2	2.39	5.01	0.05	0.25	87	---	---

9.5.2 Average and 10% Efficiency at 230 VAC

Load	P _{IN}	12 V _{OUT} at PCB	I _{OUT}	P _{OUT}	5 V _{OUT} at PCB	I _{OUT}	P _{OUT}	Efficiency at PCB	Average Efficiency	DOE6 Limit
(%)	(W)	(V _{DC})	(A)	(W)	(V _{DC})	(A)	(W)	(%)	(%)	(%)
100	29.9	11.7	2	23.4	4.91	0.5	2.46	86.4	86.7	80.7
75	22.5	11.8	1.5	17.6	4.94	0.375	1.85	86.7		
50	15	11.8	1	11.8	4.96	0.25	1.24	87		
25	7.54	11.9	0.5	5.93	4.92	0.125	0.61	87		
10	3.06	11.9	0.2	2.39	5.01	0.05	0.25	86.4	---	---



9.6 No-Load Input Power

Test Condition: The board was soaked for 15 minutes at each line voltage, and the signal was integrated for 10 seconds to derive each measurement.

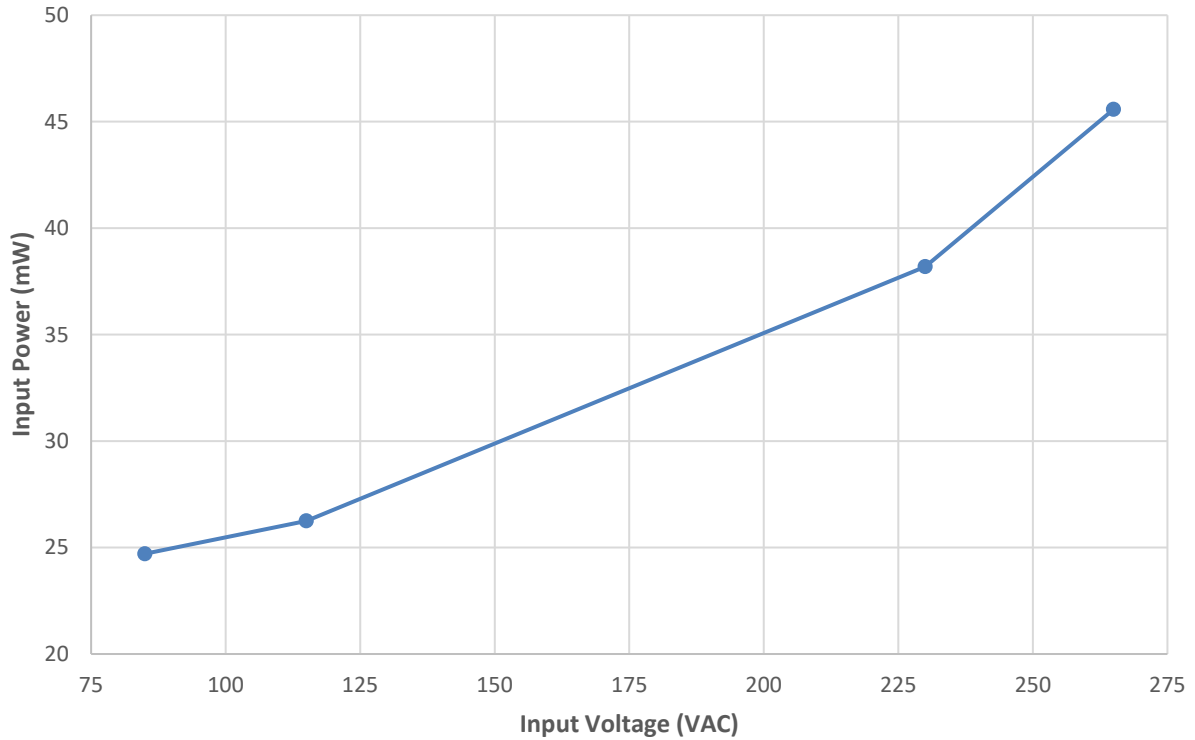

Figure 14 – No-Load Input Power vs. Line at Room Temperature.

VAC	Freq	V _{IN}	I _{IN}	P _{IN}
(RMS)	(Hz)	(RMS)	(mA)	(mW)
85	60	85	15.3	24.7
115	60	115	15.9	26.3
230	50	230	16.4	38.2
265	50	265	17	45.6

9.7 Standby Input Power

9.7.1 Standby Efficiency

Note: 12 V output and 5 V output were loaded with the same percentage load.

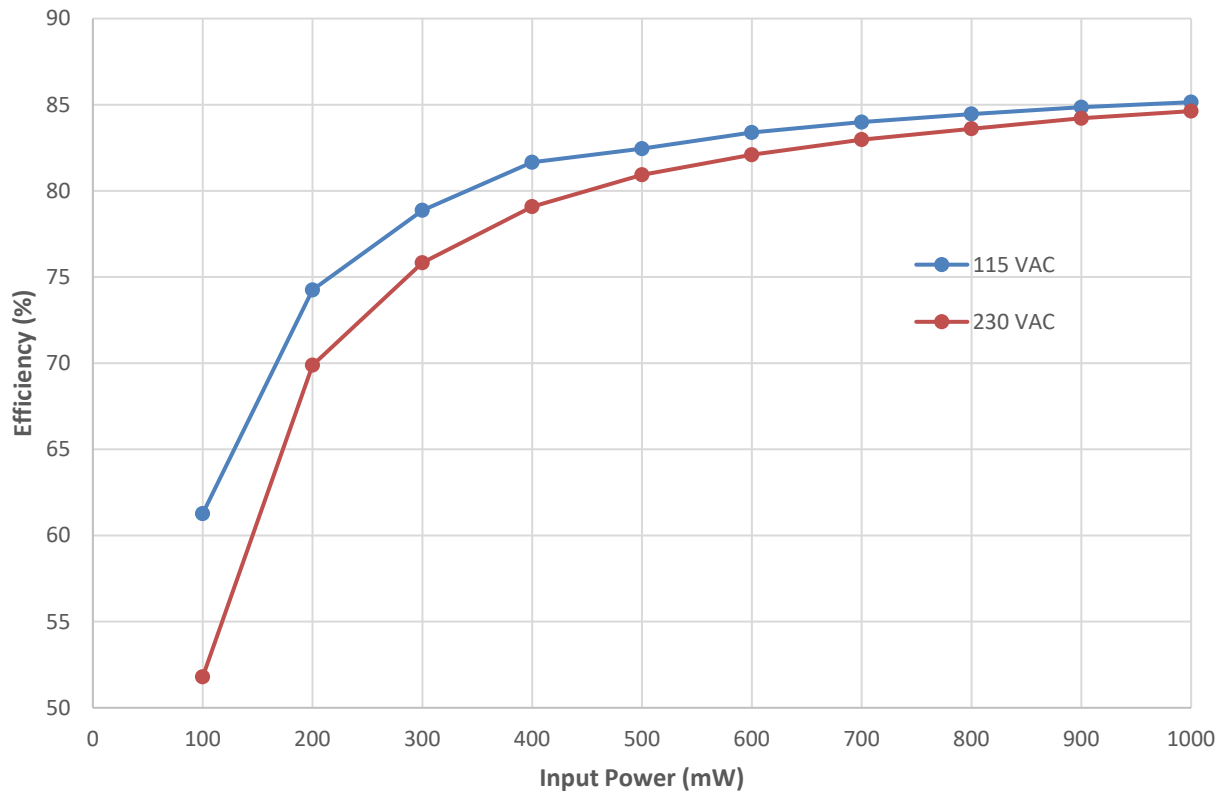

Figure 15 – Efficiency vs. Input Power

9.7.2 Power Available during Standby

Note: 12 V output and 5 V output were loaded with the same percentage load.

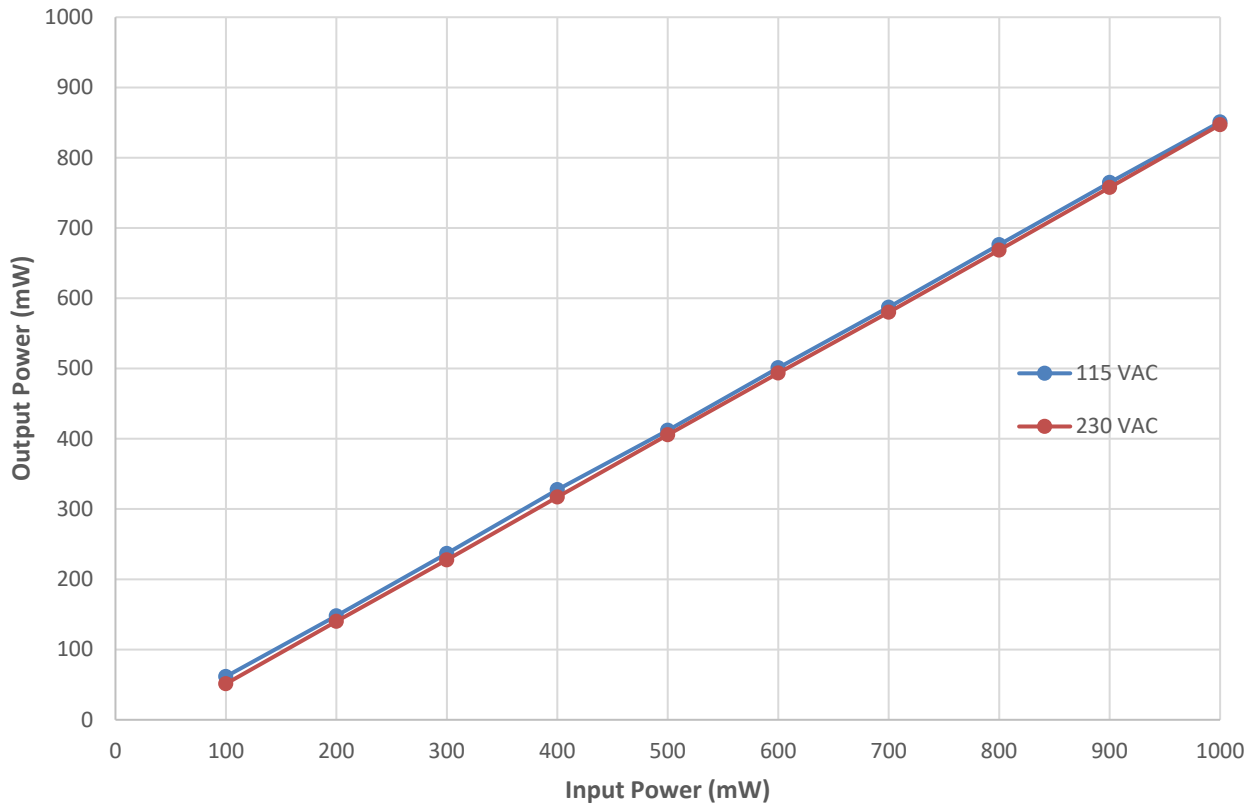

Figure 16 – Output Power vs. Input Power

9.8 Cross Regulation

9.8.1 Cross Regulation with 12 V at Minimum Load and Varying 5 V Load

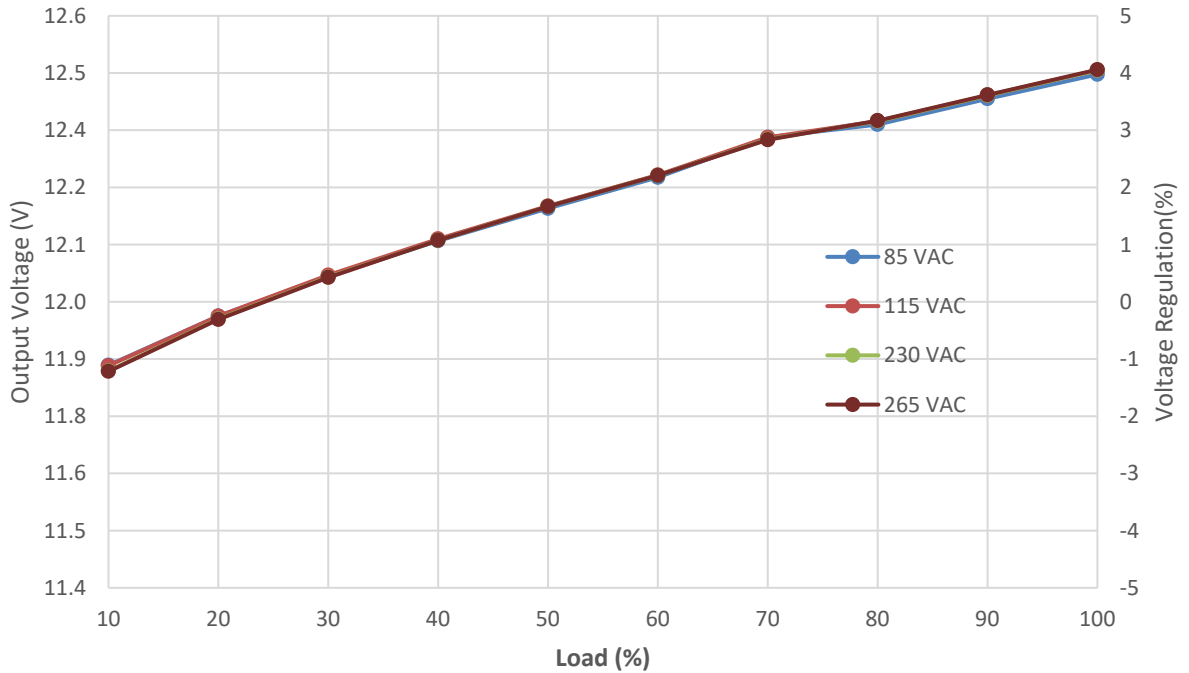

Figure 17 – 12 V Output Voltage vs. Percent Load.

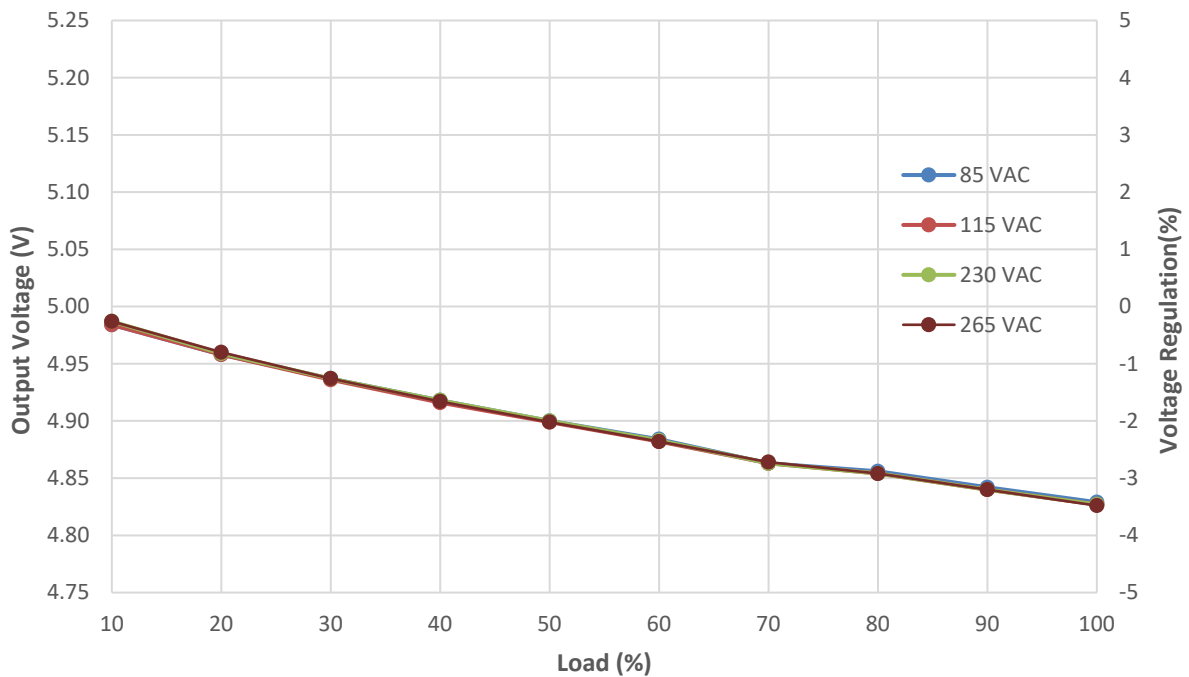

Figure 18 – 5 V Output Voltage vs. Percent Load.

9.8.2 Cross Regulation with 12 V at Full Load and Varying 5 V Load

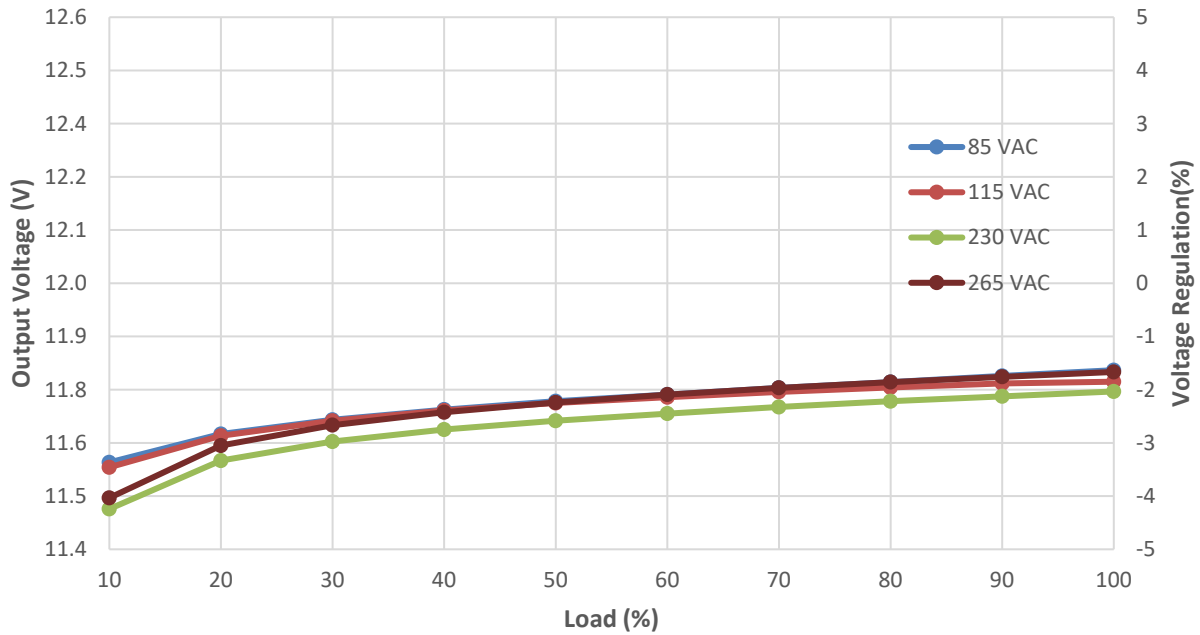

Figure 19 – 12 V Output Voltage vs. Percent Load.

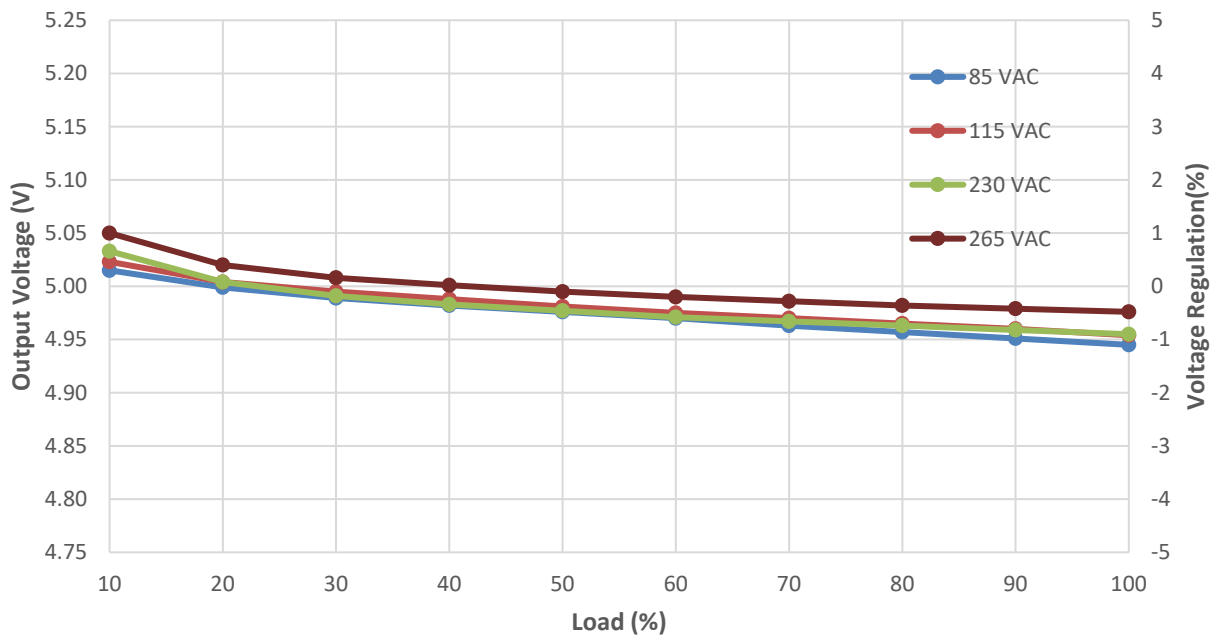

Figure 20 – 5 V Output Voltage vs. Percent Load.

9.8.3 Cross Regulation with 5 V at Minimum Load and Varying 12 V Load

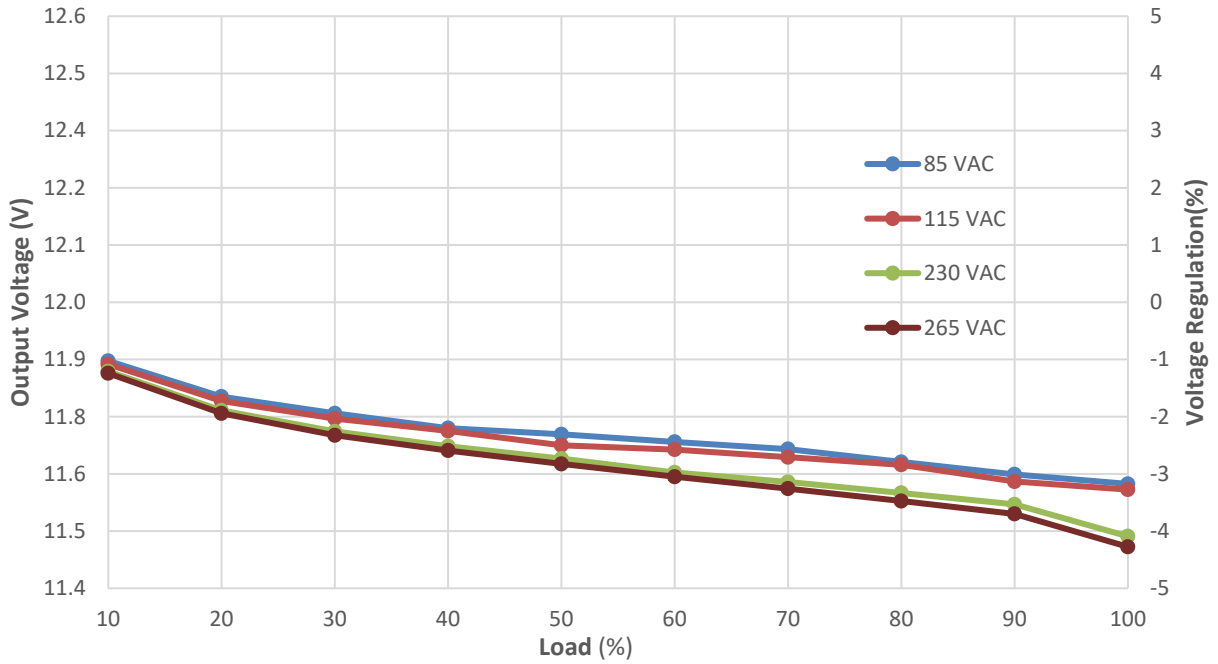

Figure 21 – 12 V Output Voltage vs. Percent Load.

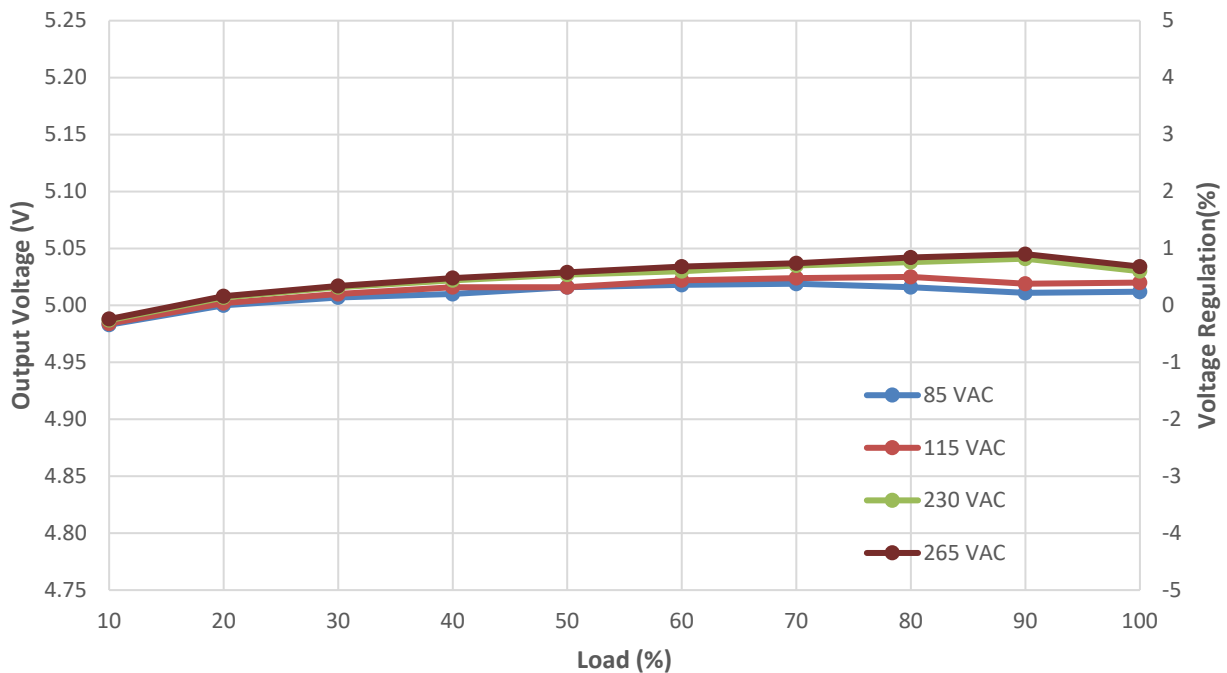

Figure 22 – 5 V Output Voltage vs. Percent Load.

9.8.4 Cross Regulation with 5 V at Full Load and Varying 12 V Load

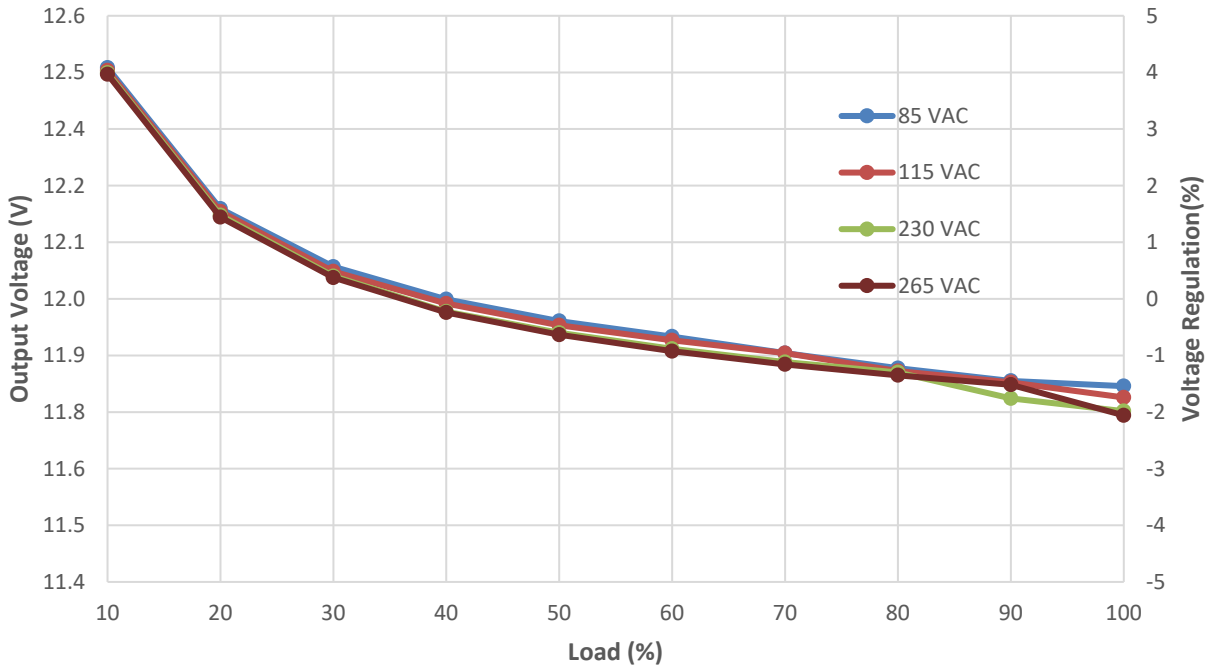

Figure 23 – 12 V Output Voltage vs. Percent Load.

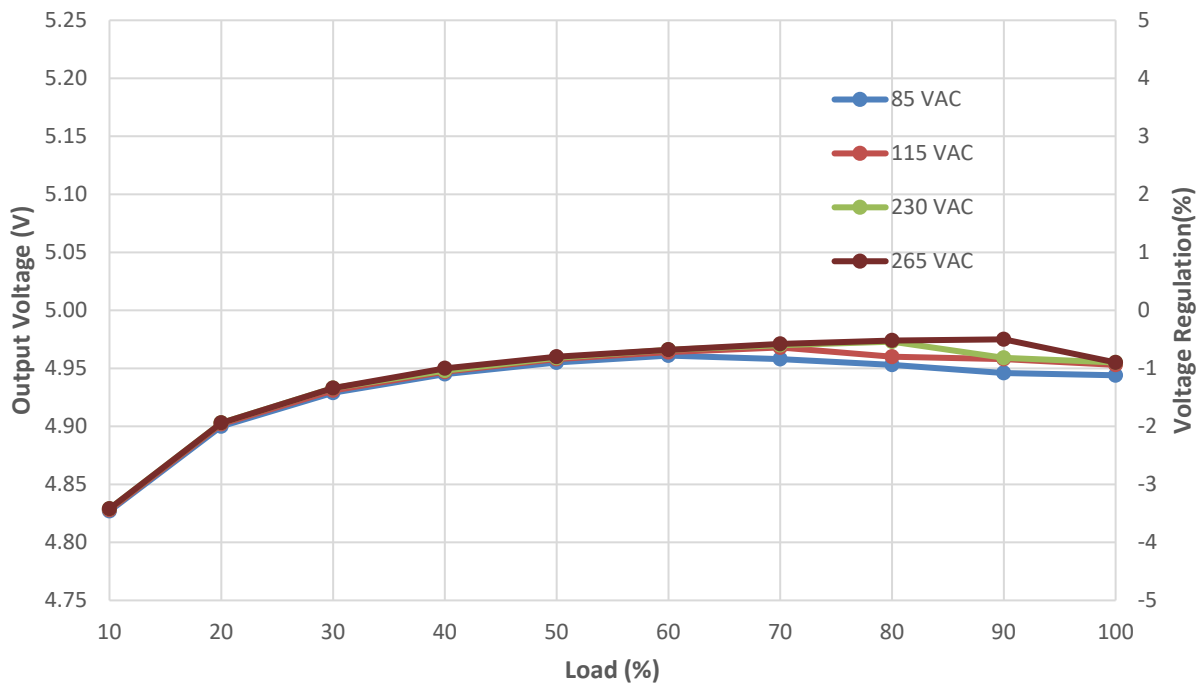

Figure 24 – 5 V Output Voltage vs. Percent Load.

10 Waveforms

10.1 Switching Waveforms

10.1.1 Primary MOSFET Drain-Source Voltage and Current at Normal Operation

10.1.1.1 Full Load

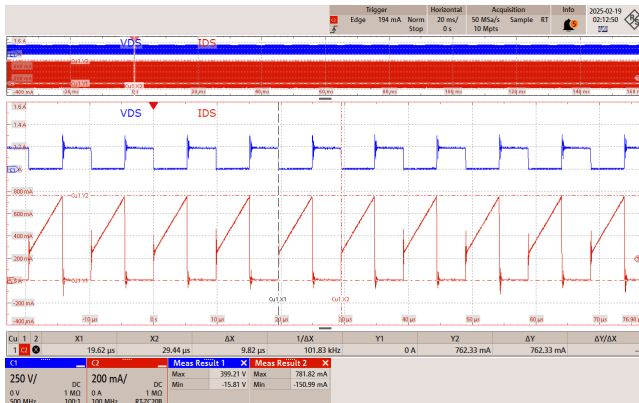

Figure 25 – 85 VAC 60 Hz.

CH1: V_{DS} , 250 V / div., 20 ms / div.
 CH2: I_{DS} , 200 mA / div., 20 ms / div.
 Zoom: 10 μ s / div.
 Drain Voltage_(MAX) = 399 V
 Drain Current_(MAX) = 782 mA



Figure 26 – 115 VAC 60 Hz.

CH1: V_{DS} , 250 V / div., 20 ms / div.
 CH2: I_{DS} , 200 mA / div., 20 ms / div.
 Zoom: 10 μ s / div.
 Drain Voltage_(MAX) = 439 V
 Drain Current_(MAX) = 790 mA



Figure 27 – 230 VAC 50 Hz.

CH1: V_{DS} , 250 V / div., 20 ms / div.
 CH2: I_{DS} , 200 mA / div., 20 ms / div.
 Zoom: 10 μ s / div.
 Drain Voltage_(MAX) = 607 V
 Drain Current_(MAX) = 813 mA



Figure 28 – 265 VAC 50 Hz.

CH1: V_{DS} , 250 V / div., 20 ms / div.
 CH2: I_{DS} , 200 mA / div., 20 ms / div.
 Zoom: 10 μ s / div.
 Drain Voltage_(MAX) = 656 V
 Drain Current_(MAX) = 821 mA

10.1.1.2 No Load

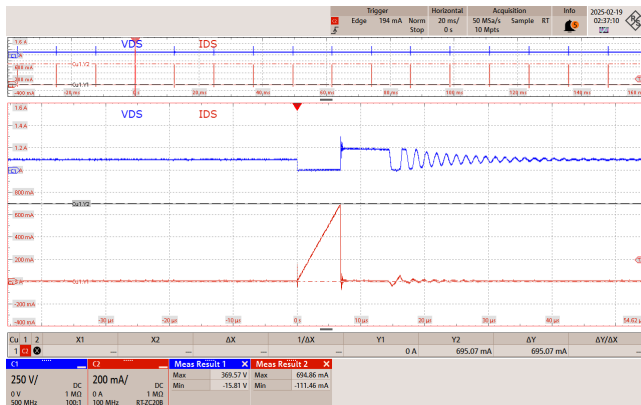

Figure 29 – 85 VAC 60 Hz.
 CH1: V_{DS} , 250 V / div., 20 ms / div.
 CH2: I_{DS} , 200 mA / div., 20 ms / div.
 Zoom: 10 μ s / div.
 Drain Voltage_(MAX) = 370 V
 Drain Current_(MAX) = 695 mA

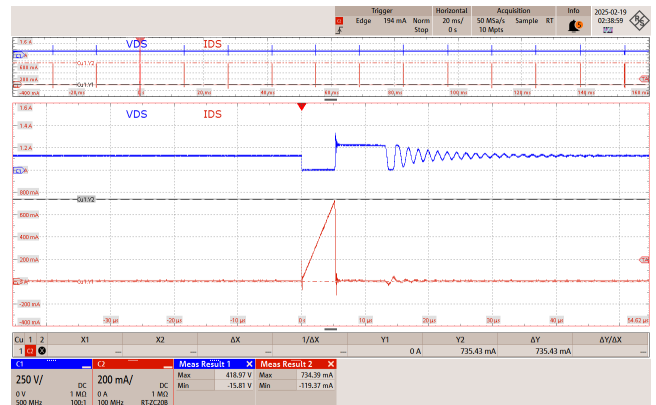

Figure 30 – 115 VAC 60 Hz.
 CH1: V_{DS} , 250 V / div., 20 ms / div.
 CH2: I_{DS} , 200 mA / div., 20 ms / div.
 Zoom: 10 μ s / div.
 Drain Voltage_(MAX) = 419 V
 Drain Current_(MAX) = 734 mA

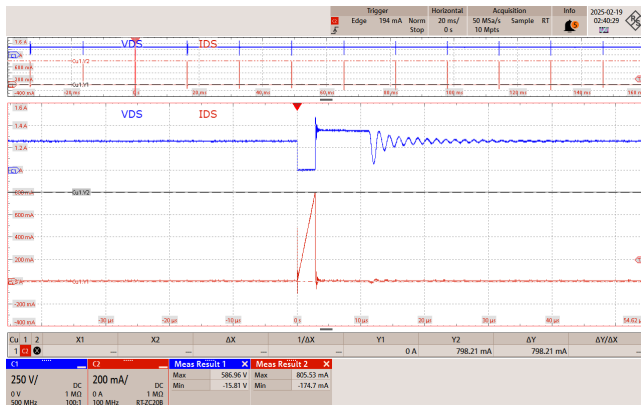

Figure 31 – 230 VAC 50 Hz.
 CH1: V_{DS} , 250 V / div., 20 ms / div.
 CH2: I_{DS} , 200 mA / div., 20 ms / div.
 Zoom: 10 μ s / div.
 Drain Voltage_(MAX) = 587 V
 Drain Current_(MAX) = 806 mA

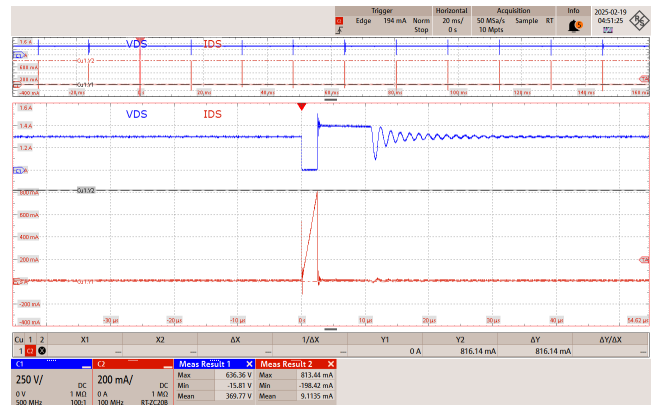

Figure 32 – 265 VAC 50 Hz.
 CH1: V_{DS} , 250 V / div., 20 ms / div.
 CH2: I_{DS} , 200 mA / div., 20 ms / div.
 Zoom: 10 μ s / div.
 Drain Voltage_(MAX) = 636 V
 Drain Current_(MAX) = 813 mA

10.1.2 Primary MOSFET Drain-Source Voltage and Current at Start-up Operation

10.1.2.1 Full Load

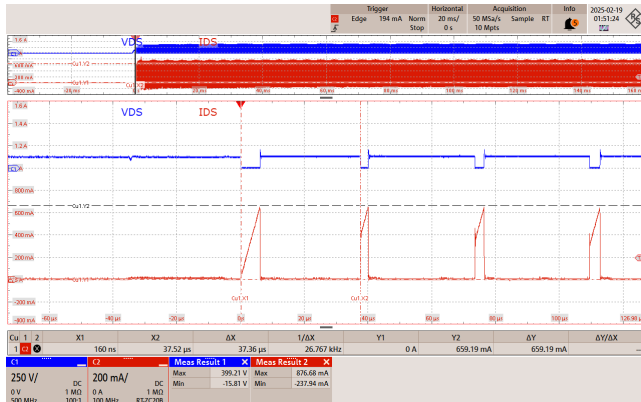

Figure 33 – 85 VAC 60 Hz.

CH1: V_{DS} , 250 V / div., 20 ms / div.
 CH2: I_{DS} , 200 mA / div., 20 ms / div.
 Zoom: 20 μ s / div.
 Drain Voltage_(MAX) = 399 V
 Drain Current_(MAX) = 877 mA

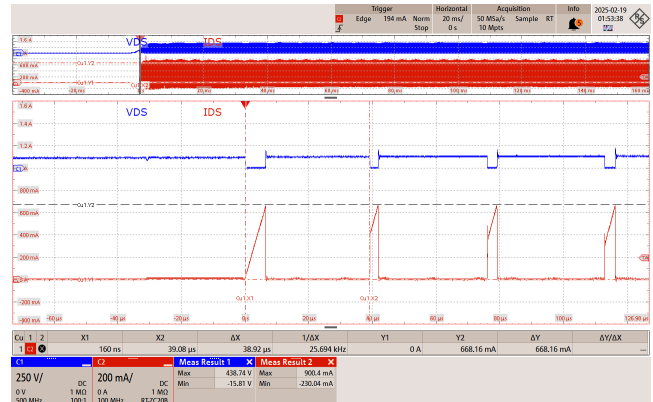

Figure 34 – 115 VAC 60 Hz.

CH1: V_{DS} , 250 V / div., 20 ms / div.
 CH2: I_{DS} , 200 mA / div., 20 ms / div.
 Zoom: 20 μ s / div.
 Drain Voltage_(MAX) = 439 V
 Drain Current_(MAX) = 900 mA

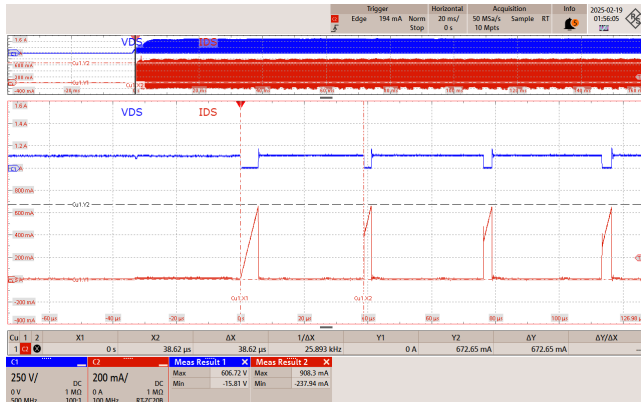

Figure 35 – 230 VAC 50 Hz.

CH1: V_{DS} , 250 V / div., 20 ms / div.
 CH2: I_{DS} , 200 mA / div., 20 ms / div.
 Zoom: 20 μ s / div.
 Drain Voltage_(MAX) = 607 V
 Drain Current_(MAX) = 908 mA

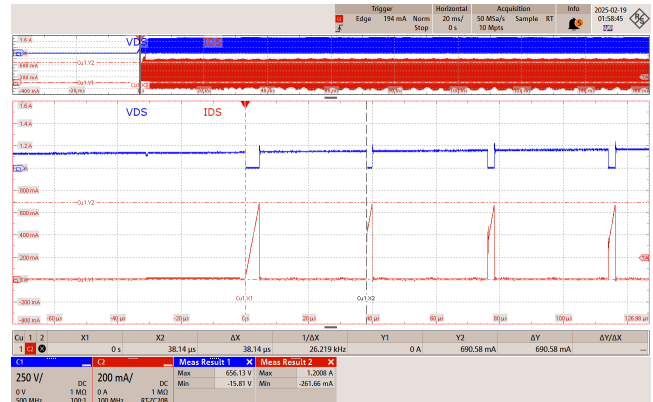

Figure 36 – 265 VAC 50 Hz.

CH1: V_{DS} , 250 V / div., 20 ms / div.
 CH2: I_{DS} , 200 mA / div., 20 ms / div.
 Zoom: 20 μ s / div.
 Drain Voltage_(MAX) = 656 V
 Drain Current_(MAX) = 1.2 A

10.1.2.2 No Load

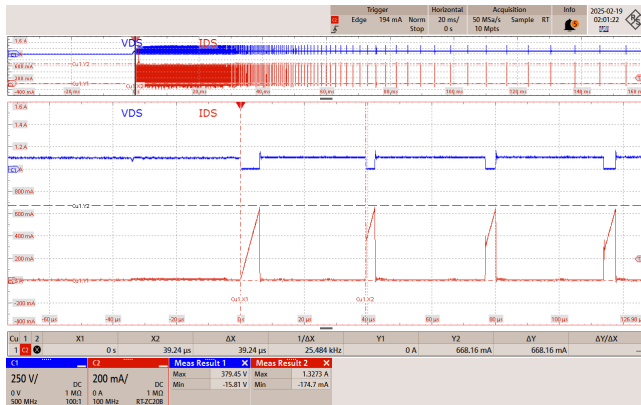

Figure 37 – 85 VAC 60 Hz.
 CH1: V_{DS} , 250 V / div., 20 ms / div.
 CH2: I_{DS} , 200 mA / div., 20 ms / div.
 Zoom: 20 μ s / div.
 Drain Voltage_(MAX) = 379 V
 Drain Current_(MAX) = 1.33 A

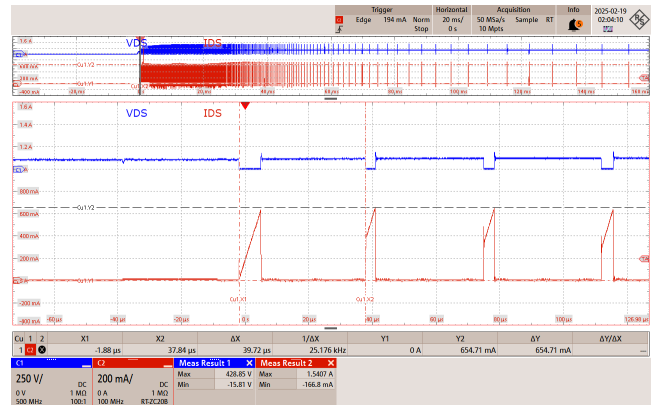

Figure 38 – 115 VAC 60 Hz.
 CH1: V_{DS} , 250 V / div., 20 ms / div.
 CH2: I_{DS} , 200 mA / div., 20 ms / div.
 Zoom: 20 μ s / div.
 Drain Voltage_(MAX) = 429 V
 Drain Current_(MAX) = 1.54 A

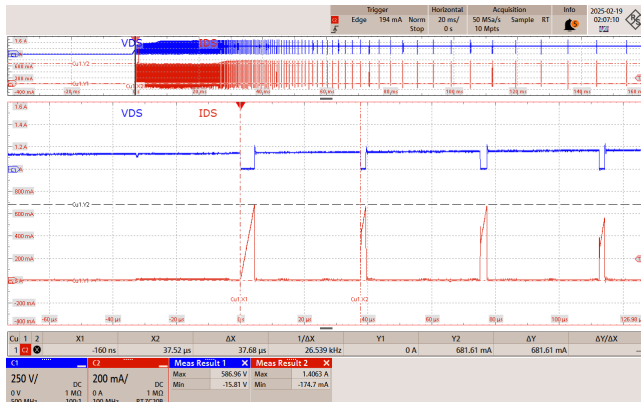

Figure 39 – 230 VAC 50 Hz.
 CH1: V_{DS} , 250 V / div., 20 ms / div.
 CH2: I_{DS} , 200 mA / div., 20 ms / div.
 Zoom: 20 μ s / div.
 Drain Voltage_(MAX) = 587 V
 Drain Current_(MAX) = 1.41 A

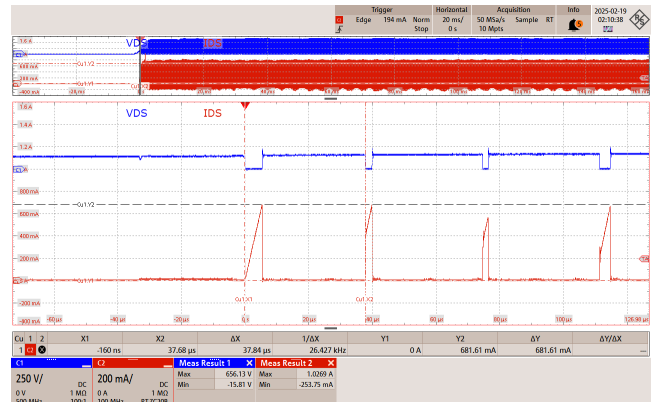

Figure 40 – 265 VAC 50 Hz.
 CH1: V_{DS} , 250 V / div., 20 ms / div.
 CH2: I_{DS} , 200 mA / div., 20 ms / div.
 Zoom: 20 μ s / div.
 Drain Voltage_(MAX) = 656 V
 Drain Current_(MAX) = 1.03 A

10.1.3 12V Freewheeling Diode Voltage at Normal Operation

10.1.3.1 Full Load

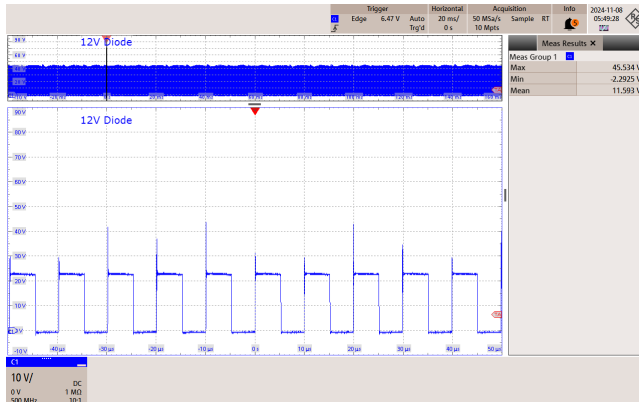

Figure 41 – 85 VAC 60 Hz.
 CH1: 12 V Diode Voltage, 10 V / div., 20 ms / div.
 Zoom : 10 μ s / div.
 Freewheel Diode Voltage_(MAX) = 45.5 V

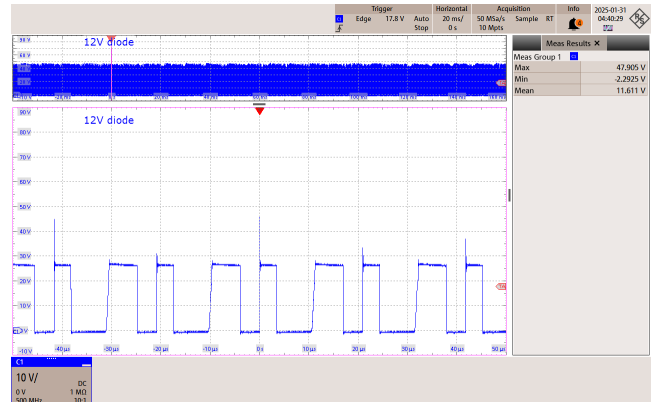

Figure 42 – 115 VAC 60 Hz.
 CH1: 12 V Diode Voltage, 10 V / div., 20 ms / div.
 Zoom : 10 μ s / div.
 Freewheel Diode Voltage_(MAX) = 47.9 V

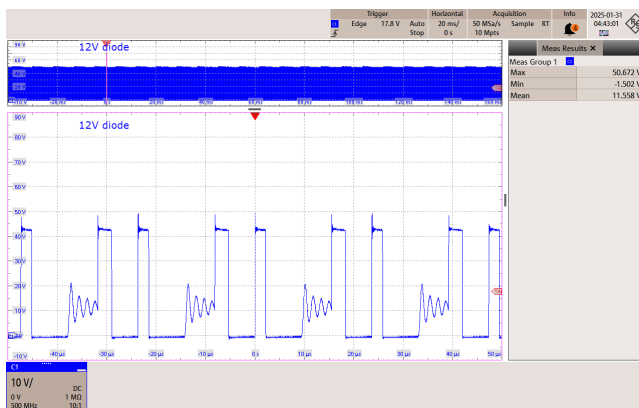

Figure 43 – 230 VAC 50 Hz.
 CH1: 12 V Diode Voltage, 10 V / div., 20 ms / div.
 Zoom : 10 μ s / div.
 Freewheel Diode Voltage_(MAX) = 50.7 V

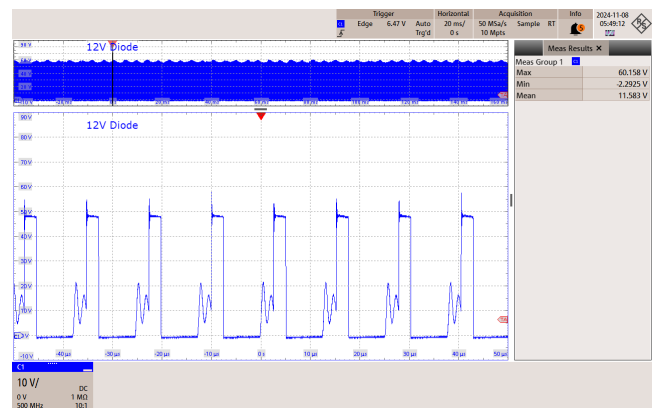

Figure 44 – 265 VAC 50 Hz.
 CH1: 12 V Diode Voltage, 10 V / div., 20 ms / div.
 Zoom : 10 μ s / div.
 Freewheel Diode Voltage_(MAX) = 60.2 V

10.1.3.2 No Load

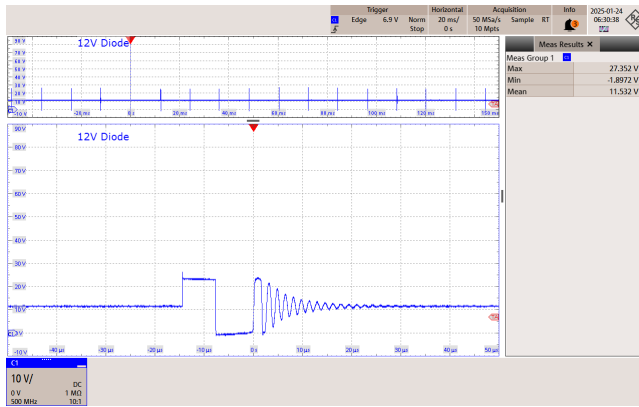

Figure 45 – 85 VAC 60 Hz.
 CH1: 12 V Diode Voltage, 10 V / div., 20 ms / div.
 Zoom : 10 μ s / div.
 Freewheel Diode Voltage_(MAX) = 27.4 V

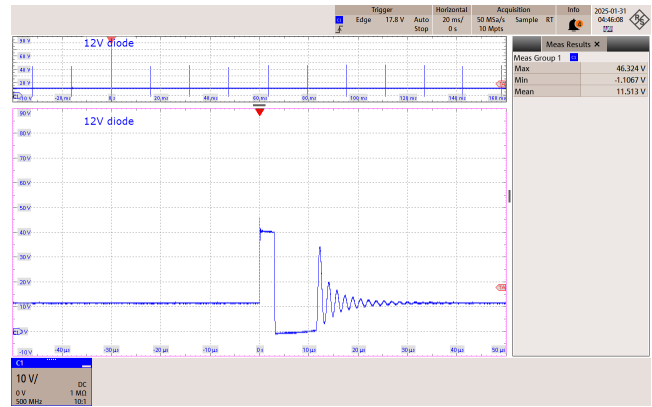

Figure 46 – 115 VAC 60 Hz.
 CH1: 12 V Diode Voltage, 10 V / div., 20 ms / div.
 Zoom : 10 μ s / div.
 Freewheel Diode Voltage_(MAX) = 46.3 V

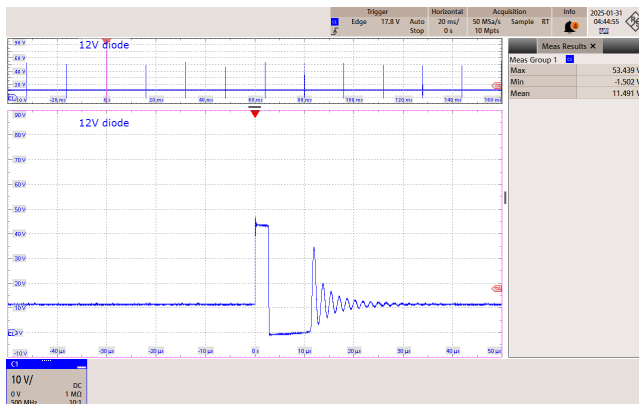

Figure 47 – 230 VAC 50 Hz.
 CH1: 12 V Diode Voltage, 10 V / div., 20 ms / div.
 Zoom : 10 μ s / div.
 Freewheel Diode Voltage_(MAX) = 53.4 V

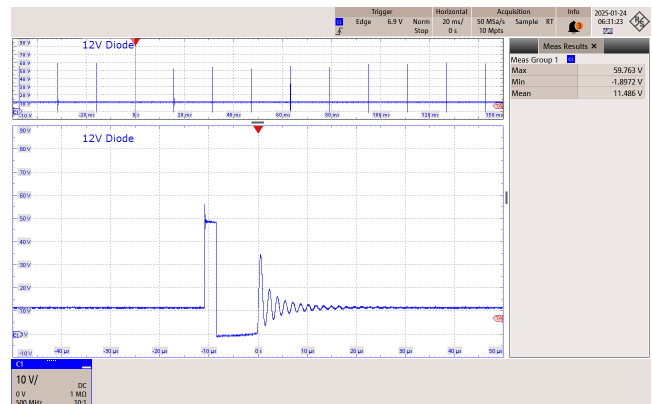

Figure 48 – 265 VAC 50 Hz.
 CH1: 12 V Diode Voltage, 10 V / div., 20 ms / div.
 Zoom : 10 μ s / div.
 Freewheel Diode Voltage_(MAX) = 59.8 V

10.1.4 12V Freewheeling Diode Voltage at Start-Up

10.1.4.1 Full Load

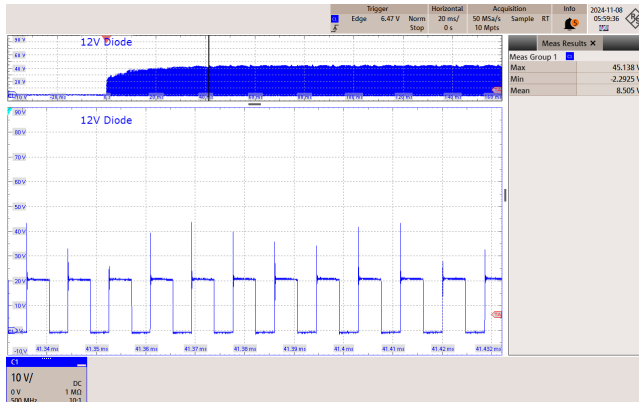

Figure 49 – 85 VAC 60 Hz.
CH1: 12 V Diode Voltage, 10 V / div., 20 ms / div.
Zoom : 10 μs / div.
Freewheel Diode Voltage_(MAX) = 45.1 V

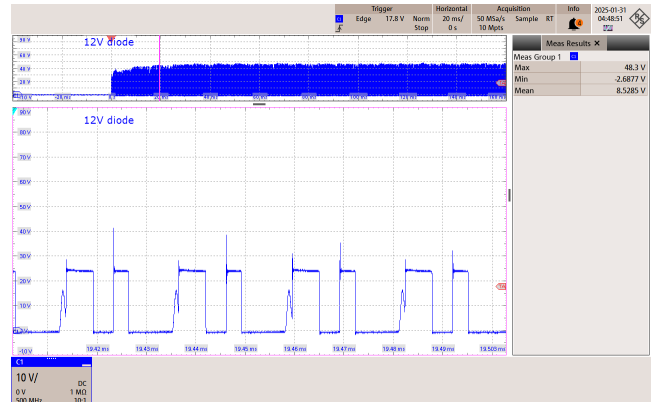

Figure 50 – 115 VAC 60 Hz.
CH1: 12 V Diode Voltage, 10 V / div., 20 ms / div.
Zoom : 10 μs / div.
Freewheel Diode Voltage_(MAX) = 48.3 V

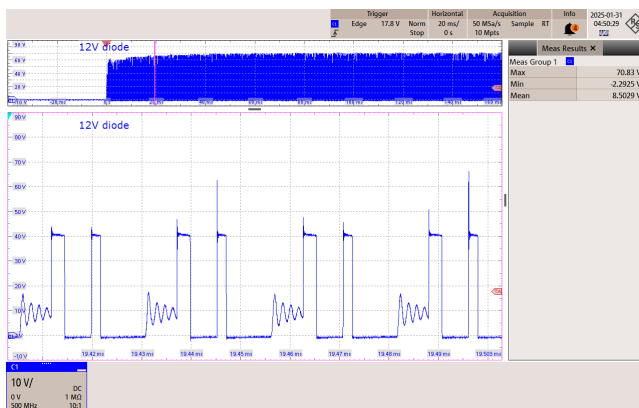

Figure 51 – 230 VAC 50 Hz.
CH1: 12 V Diode Voltage, 10 V / div., 20 ms / div.
Zoom : 10 μs / div.
Freewheel Diode Voltage_(MAX) = 70.8 V

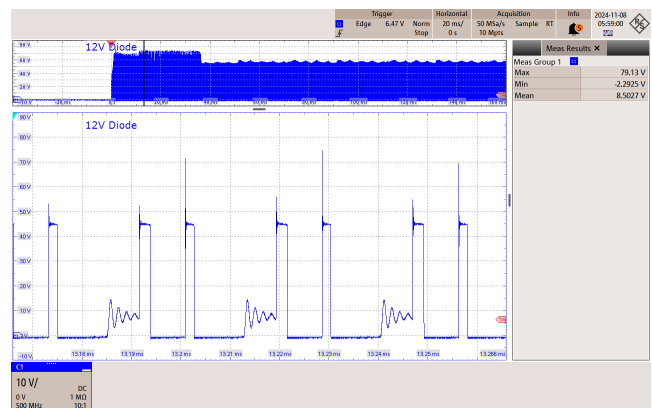

Figure 52 – 265 VAC 50 Hz.
CH1: 12 V Diode Voltage, 10 V / div., 20 ms / div.
Zoom : 10 μs / div.
Freewheel Diode Voltage_(MAX) = 79.1 V

10.1.4.2 No Load

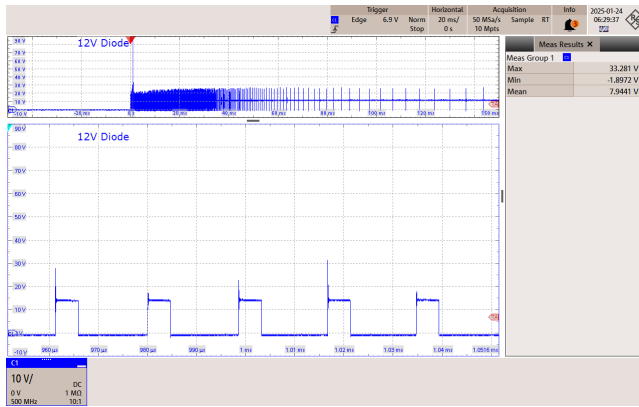

Figure 53 – 85 VAC 60 Hz.
 CH1: 12 V Diode Voltage, 10 V / div., 20 ms / div.
 Zoom : 10 μ s / div.
 Freewheel Diode Voltage_(MAX) = 33.3 V

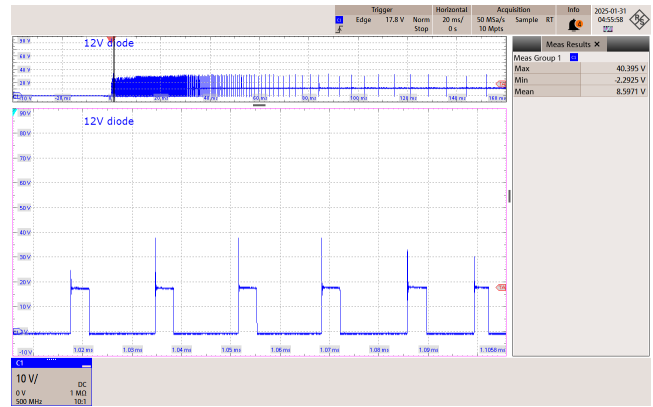

Figure 54 – 115 VAC 60 Hz.
 CH1: 12 V Diode Voltage, 10 V / div., 20 ms / div.
 Zoom : 10 μ s / div.
 Freewheel Diode Voltage_(MAX) = 40.4 V

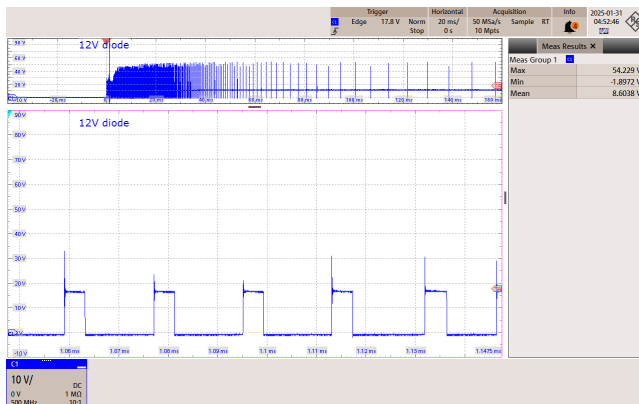

Figure 55 – 230 VAC 50 Hz.
 CH1: 12 V Diode Voltage, 10 V / div., 20 ms / div.
 Zoom : 10 μ s / div.
 Freewheel Diode Voltage_(MAX) = 54.2 V

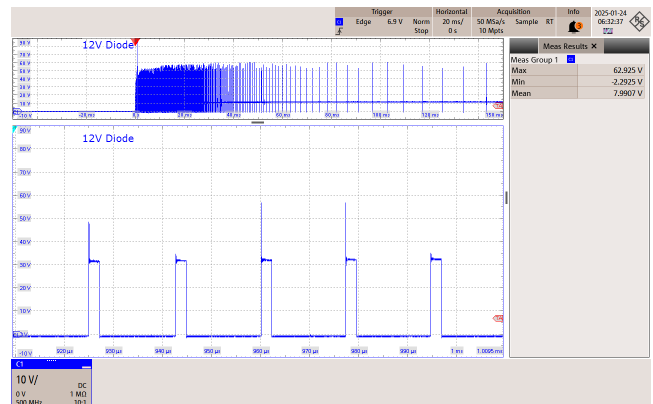

Figure 56 – 265 VAC 50 Hz.
 CH1: 12 V Diode Voltage, 10 V / div., 20 ms / div.
 Zoom : 10 μ s / div.
 Freewheel Diode Voltage_(MAX) = 62.9 V

10.1.5 5V Freewheeling Diode Voltage at Normal Operation

10.1.5.1 Full Load

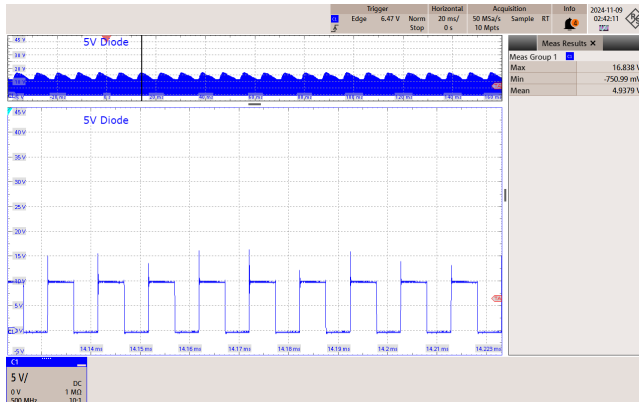

Figure 57 – 85 VAC 60 Hz.

CH1: 5 V Diode Voltage, 5 V / div., 20 ms / div.

Zoom : 10 μ s / div.

Freewheel Diode Voltage_(MAX) = 16.8 V

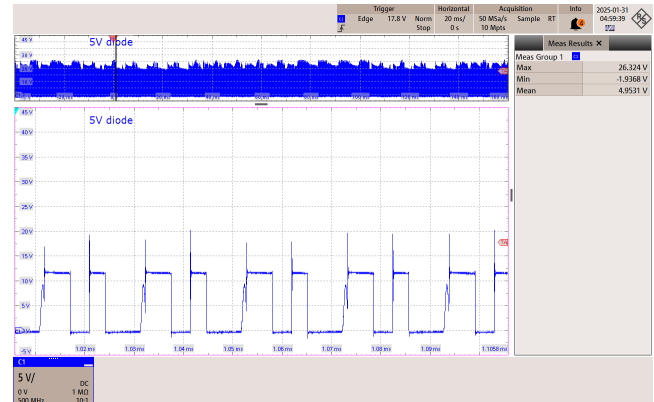

Figure 58 – 115 VAC 60 Hz.

CH1: 5 V Diode Voltage, 5 V / div., 20 ms / div.

Zoom : 10 μ s / div.

Freewheel Diode Voltage_(MAX) = 26.3 V

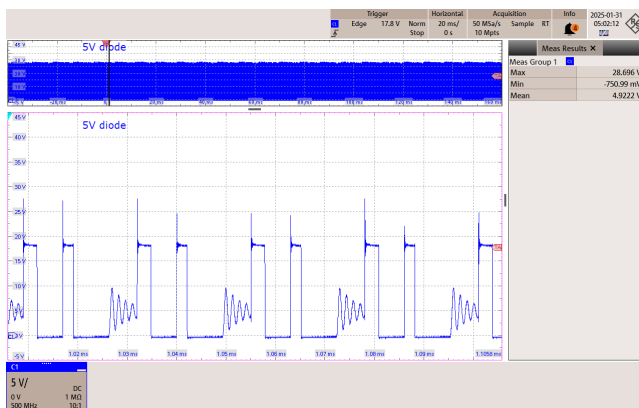

Figure 59 – 230 VAC 50 Hz.

CH1: 5 V Diode Voltage, 5 V / div., 20 ms / div.

Zoom : 10 μ s / div.

Freewheel Diode Voltage_(MAX) = 28.7 V

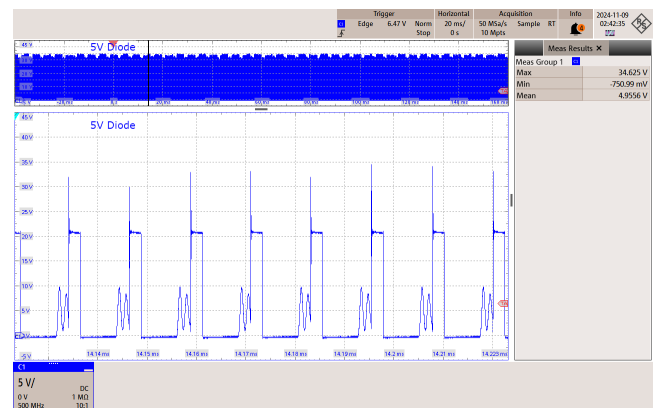

Figure 60 – 265 VAC 50 Hz.

CH1: 5 V Diode Voltage, 5 V / div., 20 ms / div.

Zoom : 10 μ s / div.

Freewheel Diode Voltage_(MAX) = 34.6 V

10.1.5.2 No Load

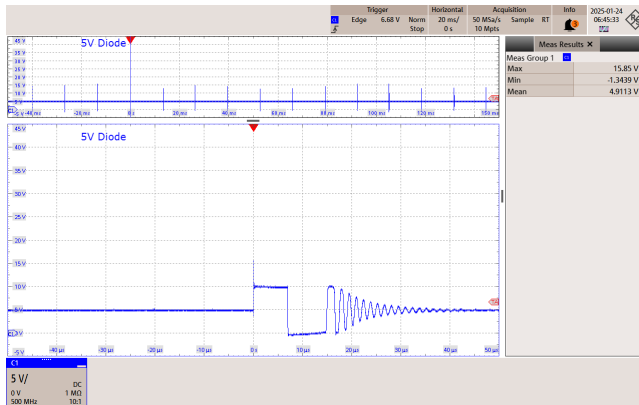

Figure 61 – 85 VAC 60 Hz.
 CH1: 5 V Diode Voltage, 5 V / div., 20 ms / div.
 Zoom : 10 μ s / div.
 Freewheel Diode Voltage_(MAX) = 15.9 V

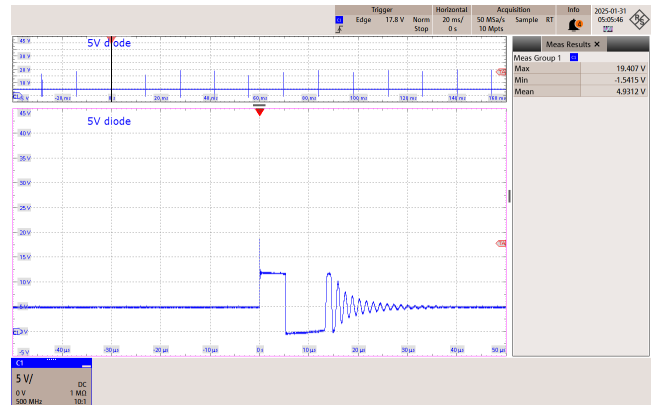

Figure 62 – 115 VAC 60 Hz.
 CH1: 5 V Diode Voltage, 5 V / div., 20 ms / div.
 Zoom : 10 μ s / div.
 Freewheel Diode Voltage_(MAX) = 19.4 V

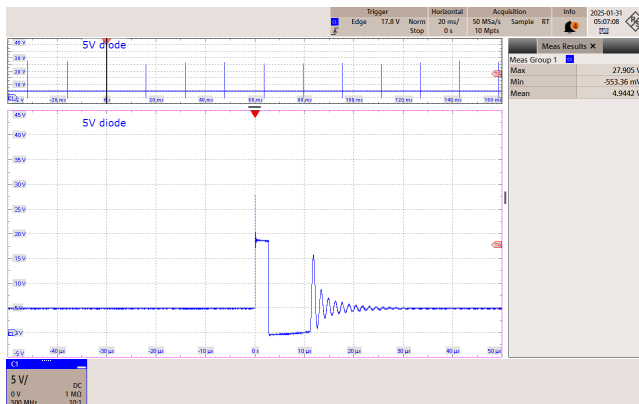

Figure 63 – 230 VAC 50 Hz.
 CH1: 5 V Diode Voltage, 5 V / div., 20 ms / div.
 Zoom : 10 μ s / div.
 Freewheel Diode Voltage_(MAX) = 27.9 V

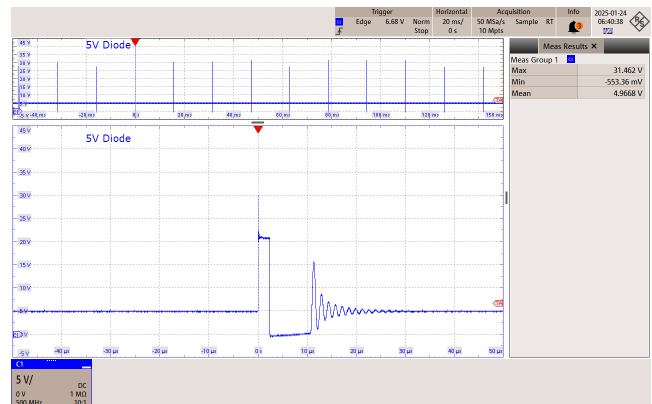

Figure 64 – 265 VAC 50 Hz.
 CH1: 5 V Diode Voltage, 5 V / div., 20 ms / div.
 Zoom : 10 μ s / div.
 Freewheel Diode Voltage_(MAX) = 31.5 V

10.1.6 5V Freewheeling Diode Voltage at Start-Up

10.1.6.1 Full Load

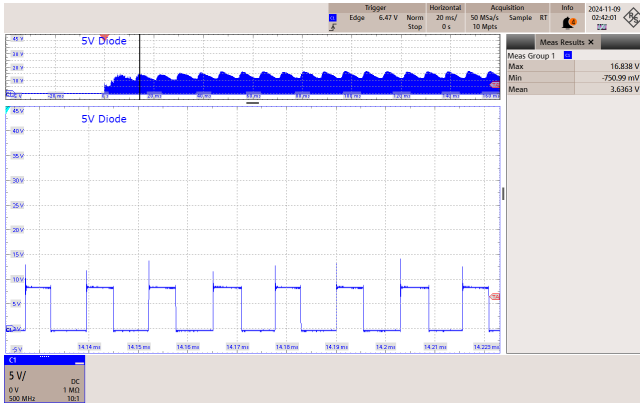

Figure 65 – 85 VAC 60 Hz.
 CH1: 5 V Diode Voltage, 5 V / div., 20 ms / div.
 Zoom : 10 μ s / div.
 Freewheel Diode Voltage_(MAX) = 16.8 V

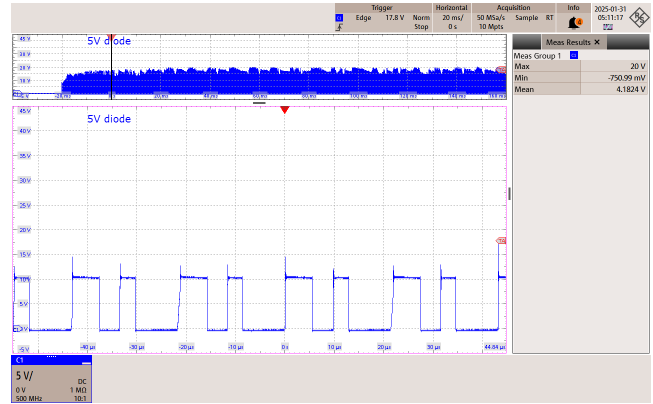

Figure 66 – 115 VAC 60 Hz.
 CH1: 5 V Diode Voltage, 5 V / div., 20 ms / div.
 Zoom : 10 μ s / div.
 Freewheel Diode Voltage_(MAX) = 20 V

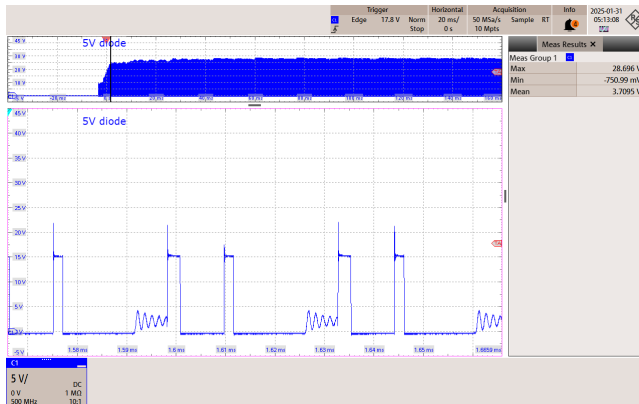

Figure 67 – 230 VAC 50 Hz.
 CH1: 5 V Diode Voltage, 5 V / div., 20 ms / div.
 Zoom : 10 μ s / div.
 Freewheel Diode Voltage_(MAX) = 28.6 V

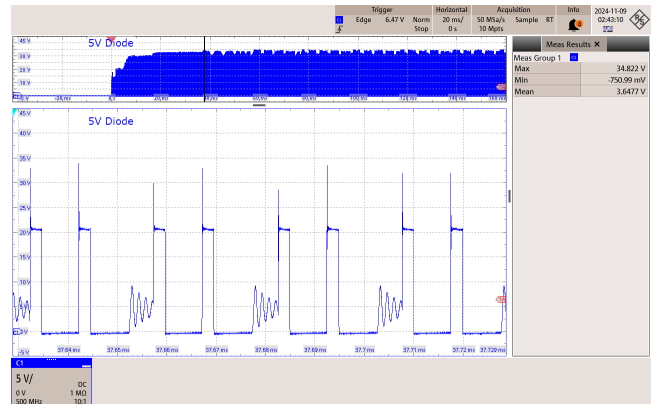

Figure 68 – 265 VAC 50 Hz.
 CH1: 5 V Diode Voltage, 5 V / div., 20 ms / div.
 Zoom : 10 μ s / div.
 Freewheel Diode Voltage_(MAX) = 34.8 V

10.1.6.2 No Load



Figure 69 – 85 VAC 60 Hz.
 CH1: 5 V Diode Voltage, 5 V / div., 20 ms / div.
 Zoom : 10 μ s / div.
 Freewheel Diode Voltage_(MAX) = 15.7 V

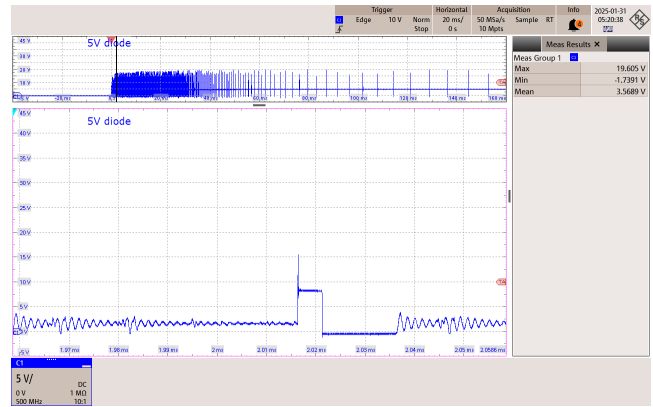

Figure 70 – 115 VAC 60 Hz.
 CH1: 5 V Diode Voltage, 5 V / div., 20 ms / div.
 Zoom : 10 μ s / div.
 Freewheel Diode Voltage_(MAX) = 19.6 V

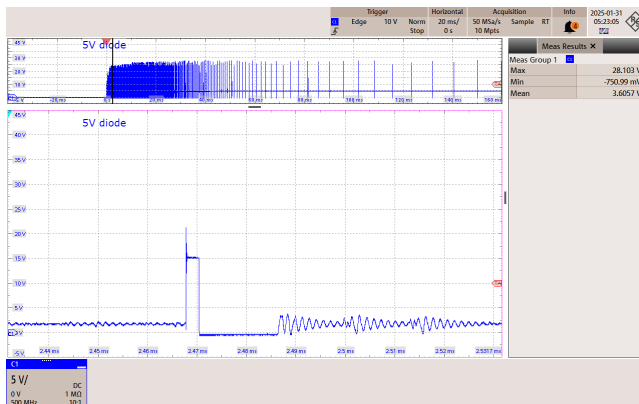

Figure 71 – 230 VAC 50 Hz.
 CH1: 5 V Diode Voltage, 5 V / div., 20 ms / div.
 Zoom : 10 μ s / div.
 Freewheel Diode Voltage_(MAX) = 28.1 V

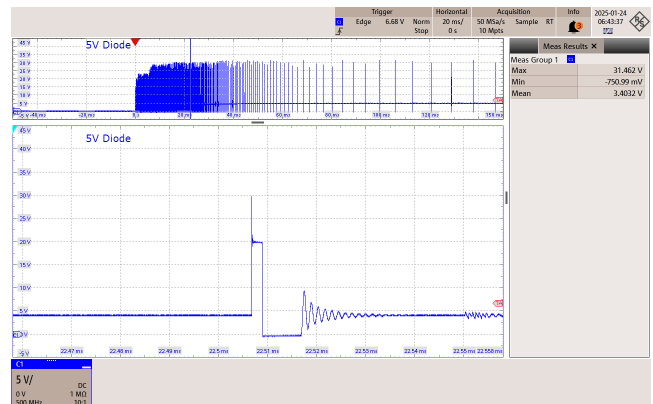

Figure 72 – 265 VAC 50 Hz.
 CH1: 5 V Diode Voltage, 5 V / div., 20 ms / div.
 Zoom : 10 μ s / div.
 Freewheel Diode Voltage_(MAX) = 31.5 V

10.1 Output Start-up

10.1.1 Full Load CC Mode

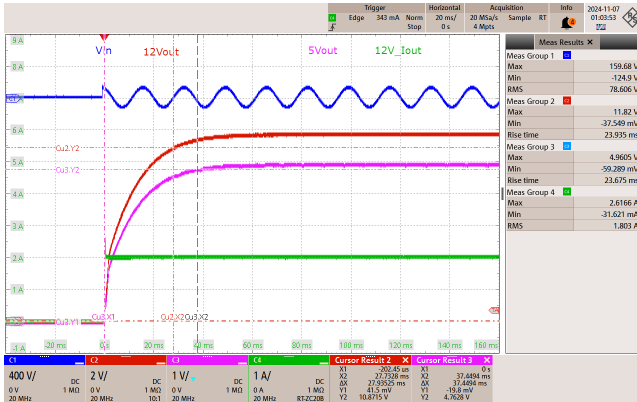

Figure 73 – 85 VAC 60 Hz.

CH1: Input Voltage, 400 V / div., 20 ms / div.
 CH2: 12 V_{OUT_Voltage}, 2 V / div., 20 ms / div.
 CH3: 5 V_{OUT_Voltage}, 1 V / div., 20 ms / div.
 CH4: 12 V_{Output Current}, 1 A / div., 20 ms / div.
 12 V_{OUT_Rise Time} = 23.9 ms.
 12 V_{OUT_VMAX} = 11.8 V
 5 V_{OUT_Rise Time} = 23.7 ms.
 5 V_{OUT_VMAX} = 4.96 V

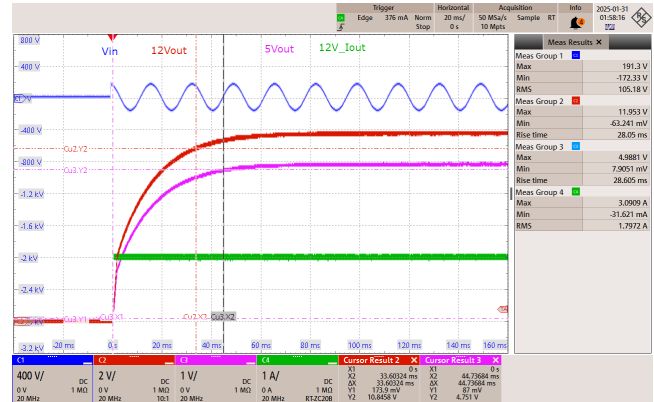

Figure 74 – 115 VAC 60 Hz.

CH1: Input Voltage, 400 V / div., 20 ms / div.
 CH2: 12 V_{OUT_Voltage}, 2 V / div., 20 ms / div.
 CH3: 5 V_{OUT_Voltage}, 1 V / div., 20 ms / div.
 CH4: 12 V_{Output Current}, 1 A / div., 20 ms / div.
 12 V_{OUT_Rise Time} = 28.1 ms.
 12 V_{OUT_VMAX} = 12 V
 5 V_{OUT_Rise Time} = 28.05 ms.
 5 V_{OUT_VMAX} = 4.99 V

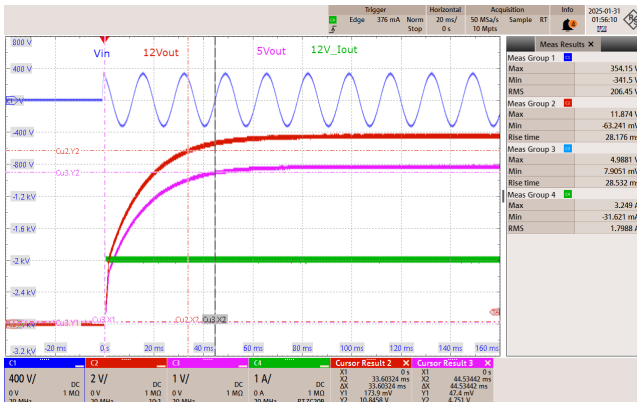

Figure 75 – 230 VAC 50 Hz.

CH1: Input Voltage, 400 V / div., 20 ms / div.
 CH2: 12 V_{OUT_Voltage}, 2 V / div., 20 ms / div.
 CH3: 5 V_{OUT_Voltage}, 1 V / div., 20 ms / div.
 CH4: 12 V_{Output Current}, 1 A / div., 20 ms / div.
 12 V_{OUT_Rise Time} = 28.2 ms.
 12 V_{OUT_VMAX} = 11.9 V
 5 V_{OUT_Rise Time} = 28.5 ms.
 5 V_{OUT_VMAX} = 4.99 V

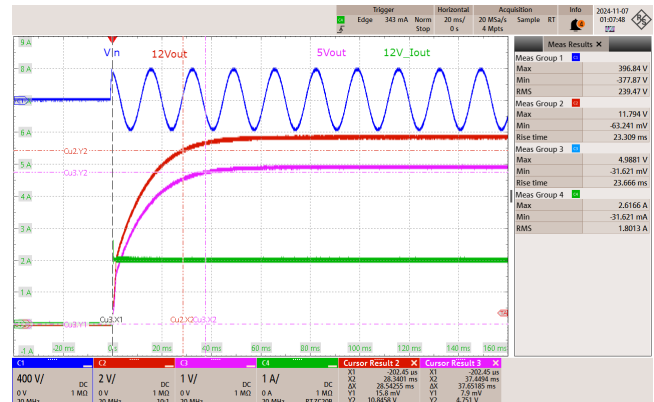

Figure 76 – 265 VAC 50 Hz.

CH1: Input Voltage, 400 V / div., 20 ms / div.
 CH2: 12 V_{OUT_Voltage}, 2 V / div., 20 ms / div.
 CH3: 5 V_{OUT_Voltage}, 1 V / div., 20 ms / div.
 CH4: 12 V_{Output Current}, 1 A / div., 20 ms / div.
 12 V_{OUT_Rise Time} = 23.3 ms.
 12 V_{OUT_VMAX} = 11.8 V
 5 V_{OUT_Rise Time} = 23.7 ms.
 5 V_{OUT_VMAX} = 4.99 V

10.1.2 Full Load CR Mode

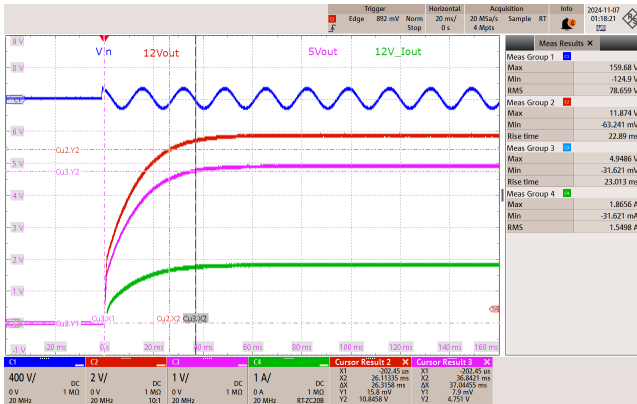

Figure 77 – 85 VAC 60 Hz.

CH1: Input Voltage, 400 V / div., 20 ms / div.
 CH2: 12 V_{OUT}_Voltage, 2 V / div., 20 ms / div.
 CH3: 5 V_{OUT}_Voltage, 1 V / div., 20 ms / div.
 CH4: 12 V_{Output} Current, 1 A / div., 20 ms / div.
 12 V_{OUT}_Rise Time = 22.9 ms.
 12 V_{OUT}_V_{MAX} = 11.9 V
 5 V_{OUT}_Rise Time = 23 ms.
 5 V_{OUT}_V_{MAX} = 4.95 V

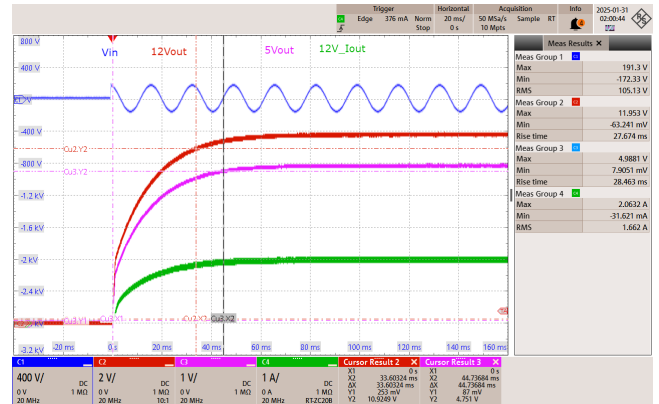

Figure 78 – 115 VAC 60 Hz.

CH1: Input Voltage, 400 V / div., 20 ms / div.
 CH2: 12 V_{OUT}_Voltage, 2 V / div., 20 ms / div.
 CH3: 5 V_{OUT}_Voltage, 1 V / div., 20 ms / div.
 CH4: 12 V_{Output} Current, 1 A / div., 20 ms / div.
 12 V_{OUT}_Rise Time = 27.7 ms.
 12 V_{OUT}_V_{MAX} = 12 V
 5 V_{OUT}_Rise Time = 28.5 ms.
 5 V_{OUT}_V_{MAX} = 4.99 V

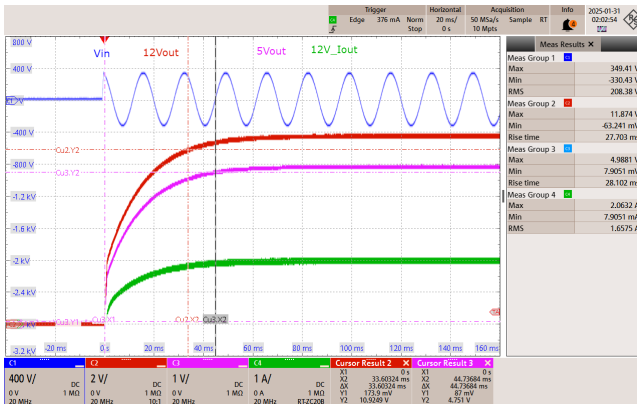

Figure 79 – 230 VAC 50 Hz.

CH1: Input Voltage, 400 V / div., 20 ms / div.
 CH2: 12 V_{OUT}_Voltage, 2 V / div., 20 ms / div.
 CH3: 5 V_{OUT}_Voltage, 1 V / div., 20 ms / div.
 CH4: 12 V_{Output} Current, 1 A / div., 20 ms / div.
 12 V_{OUT}_Rise Time = 27.7 ms.
 12 V_{OUT}_V_{MAX} = 11.9 V
 5 V_{OUT}_Rise Time = 28.1 ms.
 5 V_{OUT}_V_{MAX} = 4.99 V

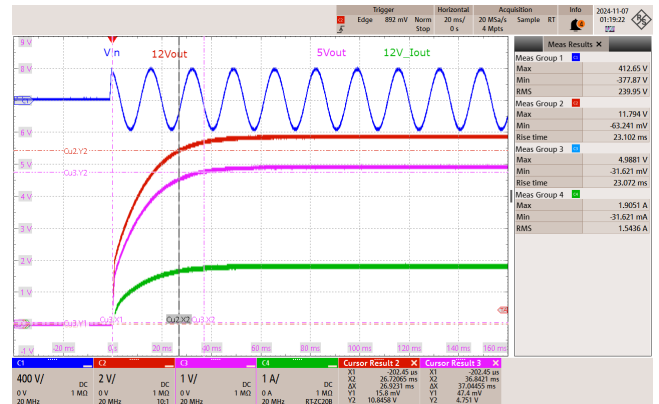

Figure 80 – 265 VAC 50 Hz.

CH1: Input Voltage, 400 V / div., 20 ms / div.
 CH2: 12 V_{OUT}_Voltage, 2 V / div., 20 ms / div.
 CH3: 5 V_{OUT}_Voltage, 1 V / div., 20 ms / div.
 CH4: 12 V_{Output} Current, 1 A / div., 20 ms / div.
 12 V_{OUT}_Rise Time = 23.02 ms.
 12 V_{OUT}_V_{MAX} = 11.8 V
 5 V_{OUT}_Rise Time = 23.1 ms.
 5 V_{OUT}_V_{MAX} = 4.99 V



10.1.3 No Load

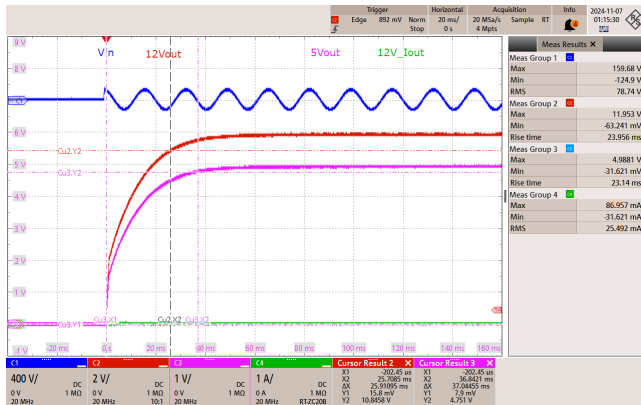

Figure 81 – 85 VAC 60 Hz.

CH1: Input Voltage, 400 V / div., 20 ms / div.
 CH2: 12 V_{OUT}_Voltage, 2 V / div., 20 ms / div.
 CH3: 5 V_{OUT}_Voltage, 1 V / div., 20 ms / div.
 CH4: 12 V_{Output} Current, 1 A / div., 20 ms / div.
 12 V_{OUT}_Rise Time = 24 ms.
 12 V_{OUT}_V_{MAX} = 12 V
 5 V_{OUT}_Rise Time = 23.1 ms.
 5 V_{OUT}_V_{MAX} = 4.99 V

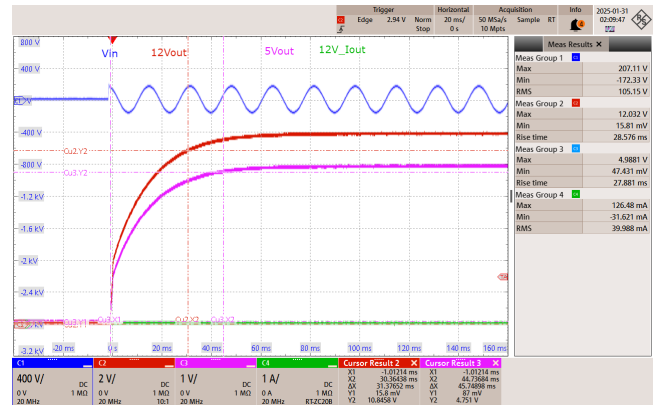

Figure 82 – 115 VAC 60 Hz.

CH1: Input Voltage, 400 V / div., 20 ms / div.
 CH2: 12 V_{OUT}_Voltage, 2 V / div., 20 ms / div.
 CH3: 5 V_{OUT}_Voltage, 1 V / div., 20 ms / div.
 CH4: 12 V_{Output} Current, 1 A / div., 20 ms / div.
 12 V_{OUT}_Rise Time = 28.6 ms.
 12 V_{OUT}_V_{MAX} = 12 V
 5 V_{OUT}_Rise Time = 27.9 ms.
 5 V_{OUT}_V_{MAX} = 4.99 V

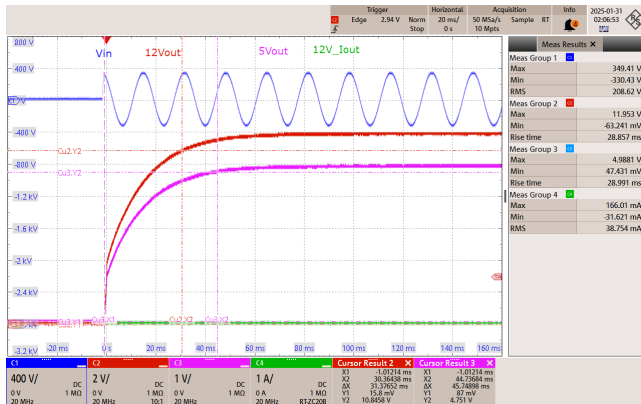

Figure 83 – 230 VAC 50 Hz.

CH1: Input Voltage, 400 V / div., 20 ms / div.
 CH2: 12 V_{OUT}_Voltage, 2 V / div., 20 ms / div.
 CH3: 5 V_{OUT}_Voltage, 1 V / div., 20 ms / div.
 CH4: 12 V_{Output} Current, 1 A / div., 20 ms / div.
 12 V_{OUT}_Rise Time = 28.9 ms.
 12 V_{OUT}_V_{MAX} = 12 V
 5 V_{OUT}_Rise Time = 29 ms.
 5 V_{OUT}_V_{MAX} = 4.99 V

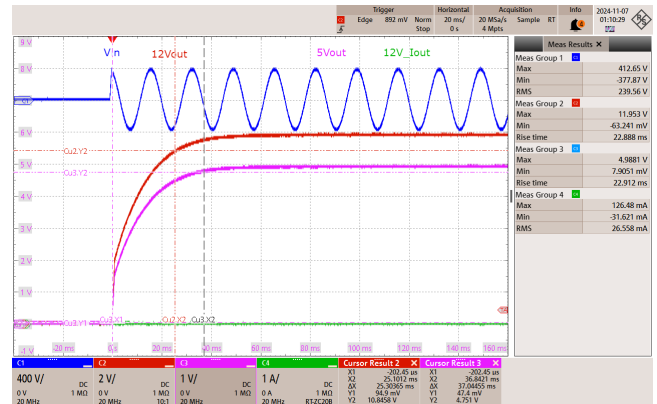

Figure 84 – 265 VAC 50 Hz.

CH1: Input Voltage, 400 V / div., 20 ms / div.
 CH2: 12 V_{OUT}_Voltage, 2 V / div., 20 ms / div.
 CH3: 5 V_{OUT}_Voltage, 1 V / div., 20 ms / div.
 CH4: 12 V_{Output} Current, 1 A / div., 20 ms / div.
 12 V_{OUT}_Rise Time = 22.9 ms.
 12 V_{OUT}_V_{MAX} = 12 V
 5 V_{OUT}_Rise Time = 22.9 ms.
 5 V_{OUT}_V_{MAX} = 4.99 V

10.2 Load Transient Response

Test Condition: Dynamic load frequency = 10 Hz, Duty cycle = 50 %, Slew Rate = 0.8 A / ms

10.2.1 Transient 5 V_{OUT} 10% - 100% Load and 12 V_{OUT} fixed at 10% Load

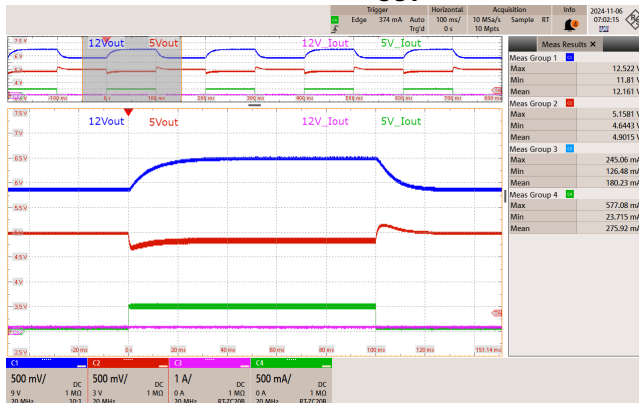

Figure 85 – 85 VAC 60 Hz.

CH1: 12 V_{OUT}_Voltage, 500 mV / div., 100 ms / div.
 CH2: 5 V_{OUT}_Voltage, 500 mV / div., 100 ms / div.
 CH3: 12 I_{OUT}_Current, 1 A / div., 100 ms / div.
 CH4: 5 I_{OUT}_Current, 500 mA / div., 100 ms / div.
 Zoom: 20 ms /div.
 12 V_{OUT}: V_{MAX}: 12.52 V
 V_{MIN}: 11.8 V
 5 V_{OUT}: V_{MAX}: 5.16 V
 V_{MIN}: 4.64 V

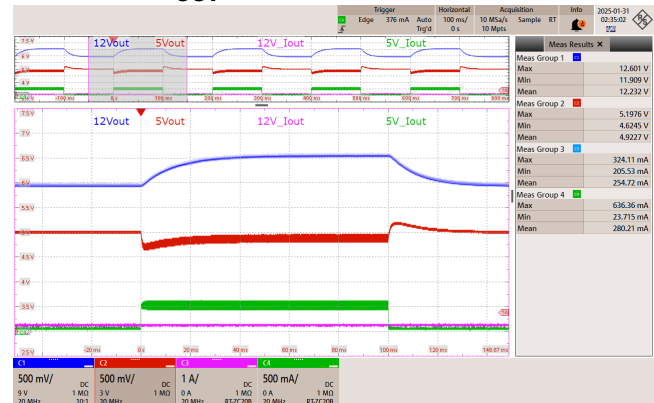

Figure 86 – 115 VAC 60 Hz.

CH1: 12 V_{OUT}_Voltage, 500 mV / div., 100 ms / div.
 CH2: 5 V_{OUT}_Voltage, 500 mV / div., 100 ms / div.
 CH3: 12 I_{OUT}_Current, 1 A / div., 100 ms / div.
 CH4: 5 I_{OUT}_Current, 500 mA / div., 100 ms / div.
 Zoom: 20 ms /div.
 12 V_{OUT}: V_{MAX}: 12.6 V
 V_{MIN}: 11.9 V
 5 V_{OUT}: V_{MAX}: 5.2 V
 V_{MIN}: 4.62 V

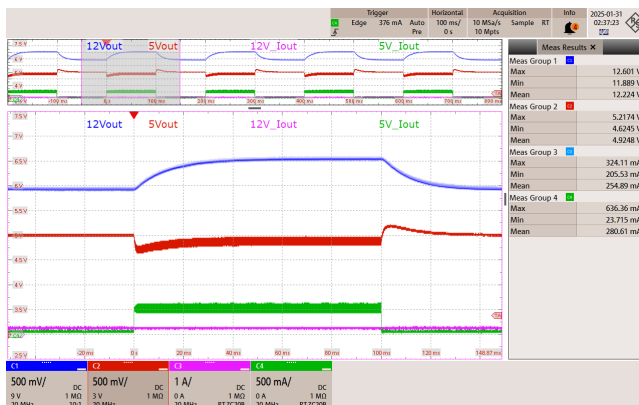

Figure 87 – 230 VAC 50 Hz.

CH1: 12 V_{OUT}_Voltage, 500 mV / div., 100 ms / div.
 CH2: 5 V_{OUT}_Voltage, 500 mV / div., 100 ms / div.
 CH3: 12 I_{OUT}_Current, 1 A / div., 100 ms / div.
 CH4: 5 I_{OUT}_Current, 500 mA / div., 100 ms / div.
 Zoom: 20 ms /div.
 12V_{OUT}: V_{MAX}: 12.6 V
 V_{MIN}: 11.9 V
 5 V_{OUT}: V_{MAX}: 5.22 V
 V_{MIN}: 4.62 V

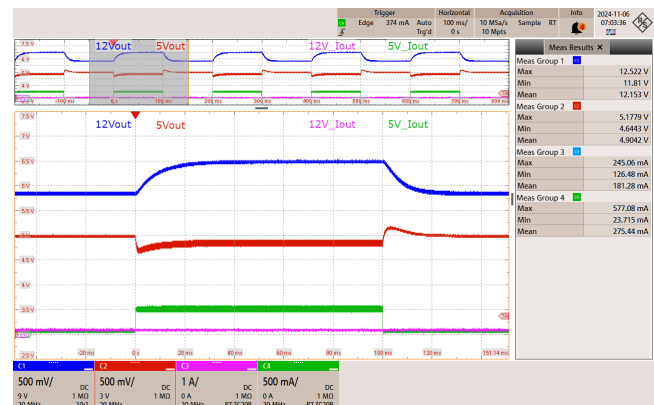

Figure 88 – 265 VAC 50 Hz.

CH1: 12 V_{OUT}_Voltage, 500 mV / div., 100 ms / div.
 CH2: 5 V_{OUT}_Voltage, 500 mV / div., 100 ms / div.
 CH3: 12 I_{OUT}_Current, 1 A / div., 100 ms / div.
 CH4: 5 I_{OUT}_Current, 500 mA / div., 100 ms / div.
 Zoom: 20 ms /div.
 12V_{OUT}: V_{MAX}: 12.6 V
 V_{MIN}: 11.8 V
 5 V_{OUT}: V_{MAX}: 5.18 V
 V_{MIN}: 4.64 V

10.2.2 Transient 5 V_{OUT} 10% - 100% Load and 12 V_{OUT} fixed at 100% Load

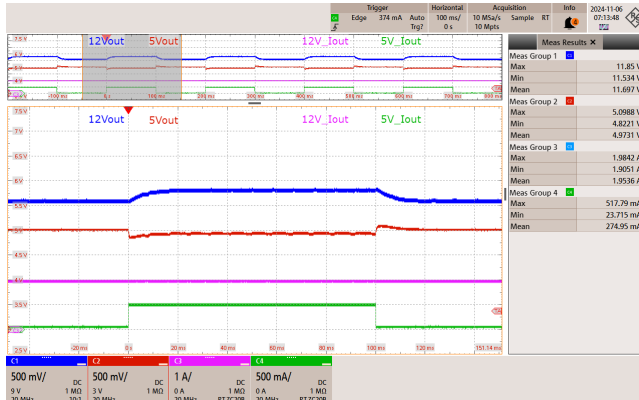

Figure 89 – 85 VAC 60 Hz.

CH1: 12 V_{OUT}_Voltage, 500 mV / div., 100 ms / div.
 CH2: 5 V_{OUT}_Voltage, 500 mV / div., 100 ms / div.
 CH3: 12 I_{OUT}_Current, 1 A / div., 100 ms / div.
 CH4: 5 I_{OUT}_Current, 500 mA / div., 100 ms / div.
 Zoom: 20 ms / div.
 12 V_{OUT}: V_{MAX}: 11.9 V
 V_{MIN}: 11.5 V
 5 V_{OUT}: V_{MAX}: 5.1 V
 V_{MIN}: 4.82 V

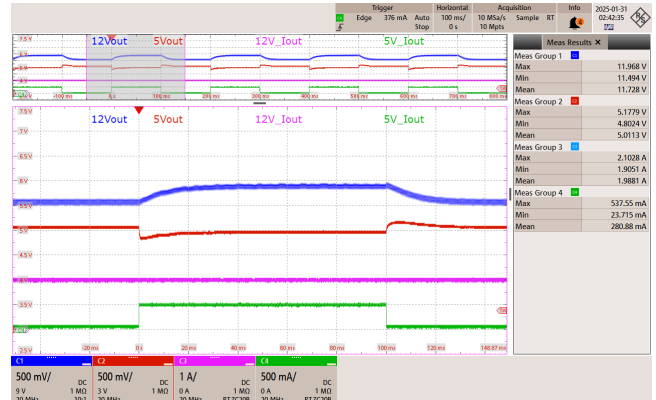

Figure 90 – 115 VAC 60 Hz.

CH1: 12 V_{OUT}_Voltage, 500 mV / div., 100 ms / div.
 CH2: 5 V_{OUT}_Voltage, 500 mV / div., 100 ms / div.
 CH3: 12 I_{OUT}_Current, 1 A / div., 100 ms / div.
 CH4: 5 I_{OUT}_Current, 500 mA / div., 100 ms / div.
 Zoom: 20ms / div.
 12 V_{OUT}: V_{MAX}: 12 V
 V_{MIN}: 11.5 V
 5 V_{OUT}: V_{MAX}: 5.2 V
 V_{MIN}: 4.8 V

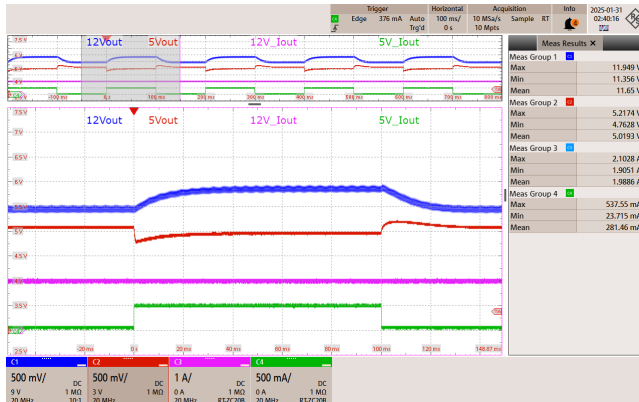

Figure 91 – 230 VAC 50 Hz.

CH1: 12 V_{OUT}_Voltage, 500 mV / div., 100 ms / div.
 CH2: 5 V_{OUT}_Voltage, 500 mV / div., 100 ms / div.
 CH3: 12 I_{OUT}_Current, 1 A / div., 100 ms / div.
 CH4: 5 I_{OUT}_Current, 500 mA / div., 100 ms / div.
 Zoom: 20 ms / div.
 12 V_{OUT}: V_{MAX}: 11.9 V
 V_{MIN}: 11.4 V
 5 V_{OUT}: V_{MAX}: 5.22 V
 V_{MIN}: 4.76 V

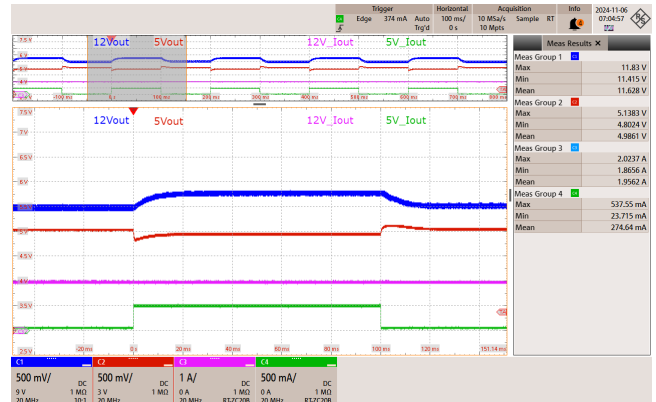

Figure 92 – 265 VAC 50 Hz.

CH1: 12 V_{OUT}_Voltage, 500 mV / div., 100 ms / div.
 CH2: 5 V_{OUT}_Voltage, 500 mV / div., 100 ms / div.
 CH3: 12 I_{OUT}_Current, 1 A / div., 100 ms / div.
 CH4: 5 I_{OUT}_Current, 500 mA / div., 100 ms / div.
 Zoom: 20 ms / div.
 12 V_{OUT}: V_{MAX}: 11.8 V
 V_{MIN}: 11.4 V
 5 V_{OUT}: V_{MAX}: 5.14 V
 V_{MIN}: 4.8 V

10.2.3 Transient 12 V_{OUT} 10% - 100% Load and 5 V_{OUT} fixed at 10% Load

Figure 93 – 85 VAC 60 Hz.

CH1: 12 V_{OUT}_Voltage, 500 mV / div., 100 ms / div.
 CH2: 5 V_{OUT}_Voltage, 500 mV / div., 100 ms / div.
 CH3: 12 I_{OUT}_Current, 1 A / div., 100 ms / div.
 CH4: 5 I_{OUT}_Current, 500 mA / div., 100 ms / div.
 Zoom: 20 ms / div.
 12 V_{OUT}: V_{MAX}: 11.9 V
 V_{MIN}: 11.5 V
 5 V_{OUT}: V_{MAX}: 5.08 V
 V_{MIN}: 4.9 V

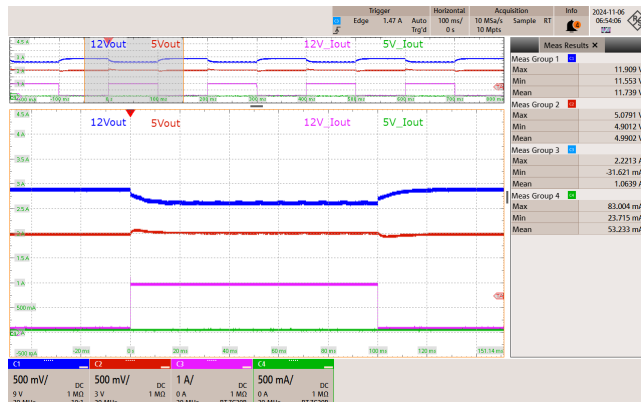
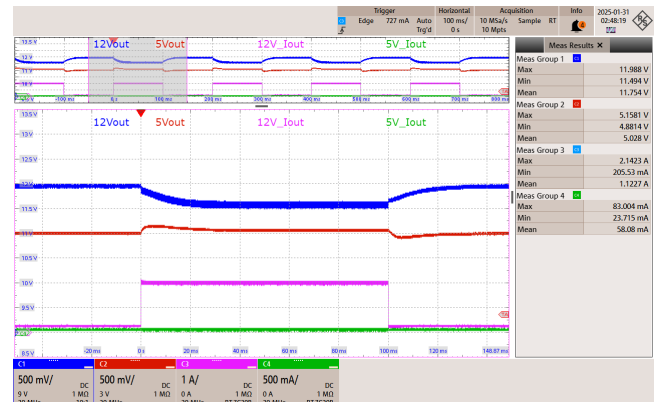

Figure 94 – 115 VAC 60 Hz.

CH1: 12 V_{OUT}_Voltage, 500 mV / div., 100 ms / div.
 CH2: 5 V_{OUT}_Voltage, 500 mV / div., 100 ms / div.
 CH3: 12 I_{OUT}_Current, 1 A / div., 100 ms / div.
 CH4: 5 I_{OUT}_Current, 500 mA / div., 100 ms / div.
 Zoom: 20 ms / div.
 12 V_{OUT}: V_{MAX}: 12 V
 V_{MIN}: 11.5 V
 5 V_{OUT}: V_{MAX}: 5.16 V
 V_{MIN}: 4.88 V

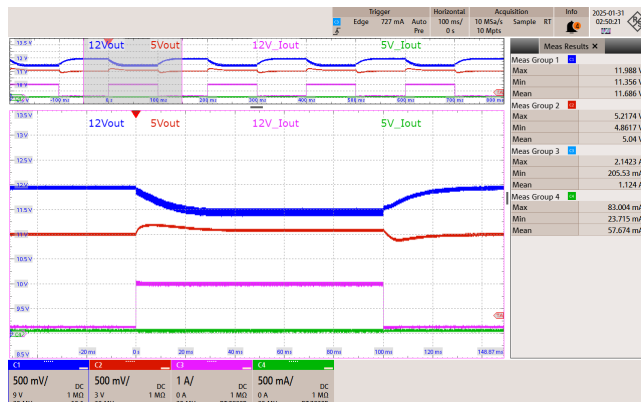

Figure 95 – 230 VAC 50 Hz.

CH1: 12 V_{OUT}_Voltage, 500 mV / div., 100 ms / div.
 CH2: 5 V_{OUT}_Voltage, 500 mV / div., 100 ms / div.
 CH3: 12 I_{OUT}_Current, 1 A / div., 100 ms / div.
 CH4: 5 I_{OUT}_Current, 500 mA / div., 100 ms / div.
 Zoom: 20 ms / div.
 12 V_{OUT}: V_{MAX}: 12 V
 V_{MIN}: 11.4 V
 5 V_{OUT}: V_{MAX}: 5.22 V
 V_{MIN}: 4.86 V

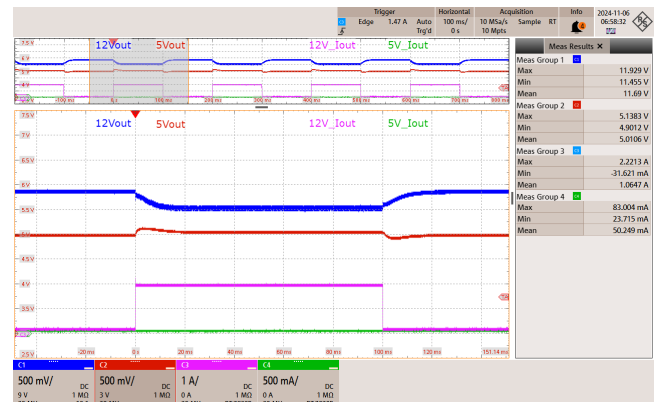

Figure 96 – 265 VAC 50 Hz.

CH1: 12 V_{OUT}_Voltage, 500 mV / div., 100 ms / div.
 CH2: 5 V_{OUT}_Voltage, 500 mV / div., 100 ms / div.
 CH3: 12 I_{OUT}_Current, 1 A / div., 100 ms / div.
 CH4: 5 I_{OUT}_Current, 500 mA / div., 100 ms / div.
 Zoom: 20 ms / div.
 12 V_{OUT}: V_{MAX}: 11.9 V
 V_{MIN}: 11.5 V
 5 V_{OUT}: V_{MAX}: 5.14 V
 V_{MIN}: 4.9 V

10.2.4 Transient 12 V_{OUT} 10% - 100% Load and V_{OUT} fixed at 100% Load

Figure 97 – 85 VAC 60 Hz.

CH1: 12 V_{OUT}_Voltage, 500 mV / div., 100 ms / div.
 CH2: 5 V_{OUT}_Voltage, 500 mV / div., 100 ms / div.
 CH3: 12 I_{OUT}_Current, 1 A / div., 100 ms / div.
 CH4: 5 I_{OUT}_Current, 500 mA / div., 100 ms / div.
 Zoom: 20 ms/div.
 12 V_{OUT}: V_{MAX}: 12.5 V
 V_{MIN}: 11.8 V
 5 V_{OUT}: V_{MAX}: 5.18 V
 V_{MIN}: 4.64 V

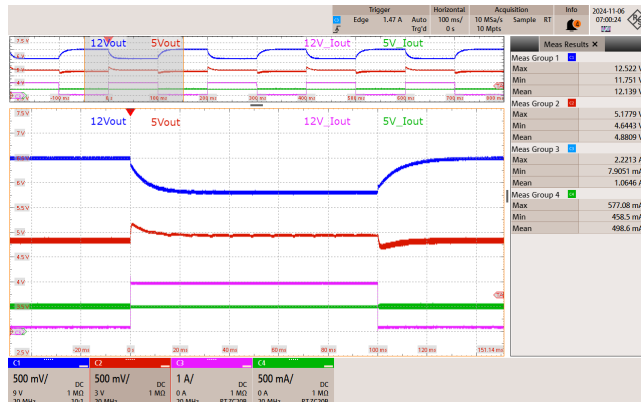
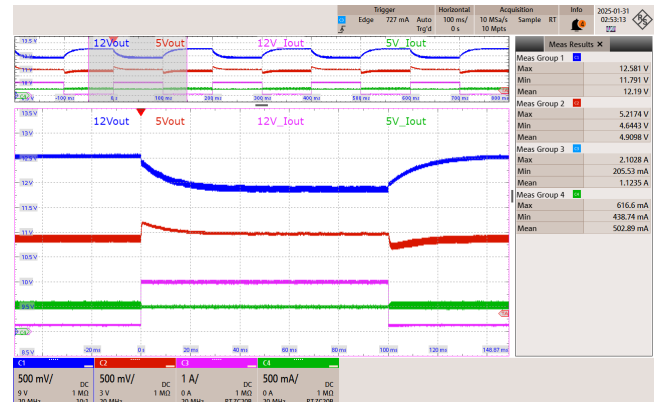

Figure 98 – 115 VAC 60 Hz.

CH1: 12 V_{OUT}_Voltage, 500 mV / div., 100 ms / div.
 CH2: 5 V_{OUT}_Voltage, 500 mV / div., 100 ms / div.
 CH3: 12 I_{OUT}_Current, 1 A / div., 100 ms / div.
 CH4: 5 I_{OUT}_Current, 500 mA / div., 100 ms / div.
 Zoom: 20 ms/div.
 12 V_{OUT}: V_{MAX}: 12.6 V
 V_{MIN}: 11.8 V
 5 V_{OUT}: V_{MAX}: 5.22 V
 V_{MIN}: 4.64 V

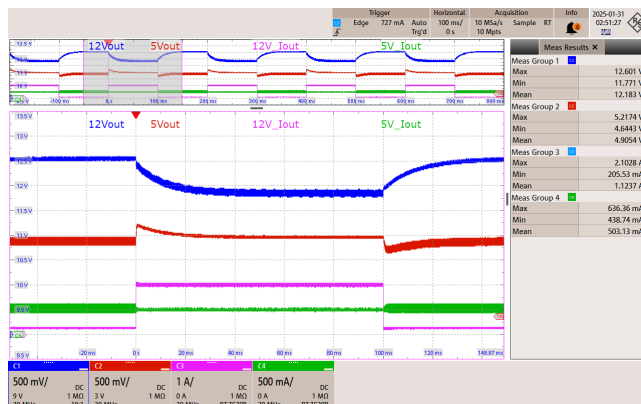

Figure 99 – 230 VAC 50 Hz.

CH1: 12 V_{OUT}_Voltage, 500 mV / div., 100 ms / div.
 CH2: 5 V_{OUT}_Voltage, 500 mV / div., 100 ms / div.
 CH3: 12 I_{OUT}_Current, 1 A / div., 100 ms / div.
 CH4: 5 I_{OUT}_Current, 500 mA / div., 100 ms / div.
 Zoom: 20 ms/div.
 12 V_{OUT}: V_{MAX}: 12.6 V
 V_{MIN}: 11.8 V
 5 V_{OUT}: V_{MAX}: 5.22 V
 V_{MIN}: 4.64 V

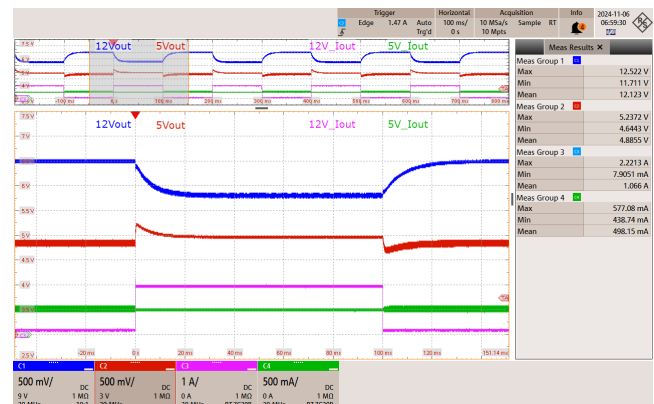

Figure 100 – 265 VAC 50 Hz.

CH1: 12 V_{OUT}_Voltage, 500 mV / div., 100 ms / div.
 CH2: 5 V_{OUT}_Voltage, 500 mV / div., 100 ms / div.
 CH3: 12 I_{OUT}_Current, 1 A / div., 100 ms / div.
 CH4: 5 I_{OUT}_Current, 500 mA / div., 100 ms / div.
 Zoom: 20 ms/div.
 12 V_{OUT}: V_{MAX}: 12.6 V
 V_{MIN}: 11.7 V
 5 V_{OUT}: V_{MAX}: 5.24 V
 V_{MIN}: 4.64 V

10.3 Output Voltage Ripple

10.3.1 Ripple Measurement Technique

For DC output ripple measurements, a modified oscilloscope test probe must be utilized to reduce spurious signals due to pick-up. Details of the probe modification are provided in the Figures below.

The 4987BA probe adapter is affixed with two capacitors tied in parallel across the probe tip. The capacitors include one (1) 0.1 μF / 50 V ceramic type and one (1) 47 μF / 50 V aluminum electrolytic. The aluminum electrolytic type capacitor is polarized, so proper polarity across DC outputs must be maintained (see below).

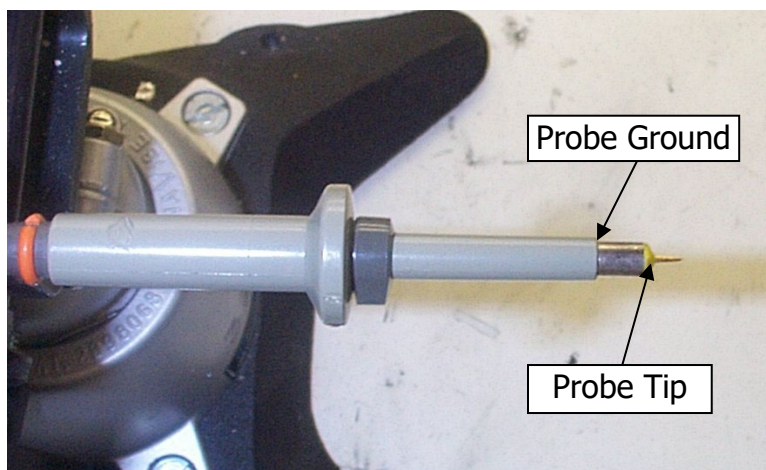

Figure 101 – Oscilloscope Probe Prepared for Ripple Measurement. (End Cap and Ground Lead Removed)

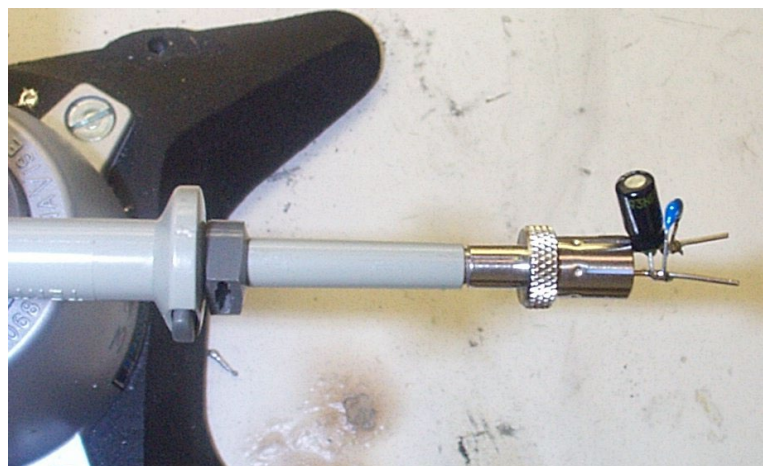

Figure 102 – Oscilloscope Probe with Probe Master (www.probemaster.com) 4987A BNC Adapter. (Modified with wires for ripple measurement, and two parallel decoupling capacitors added)

10.3.2 Measurement Results

Note: All ripple measurements were taken at PCB end.

10.3.2.1 100% Load Condition

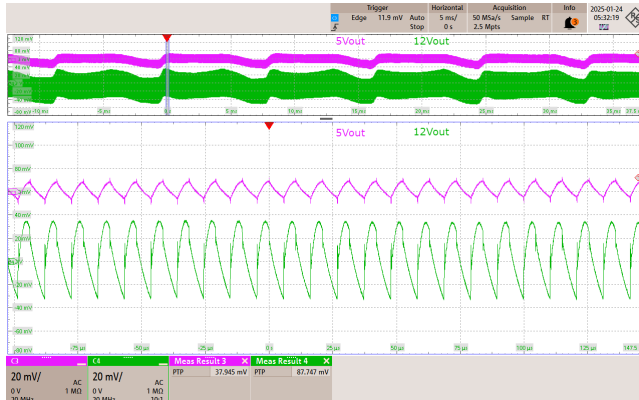

Figure 103 – 85 VAC 60 Hz.

CH3: 5 V_Output Ripple, 20 mV / div., 5 ms / div.
 CH4: 12 V_Output Ripple, 20 mV / div., 5 ms / div.
 Zoom: 25 μ s / div.
 5 V_Output Ripple = 37.9 mV
 12 V_Output Ripple = 87.8 mV

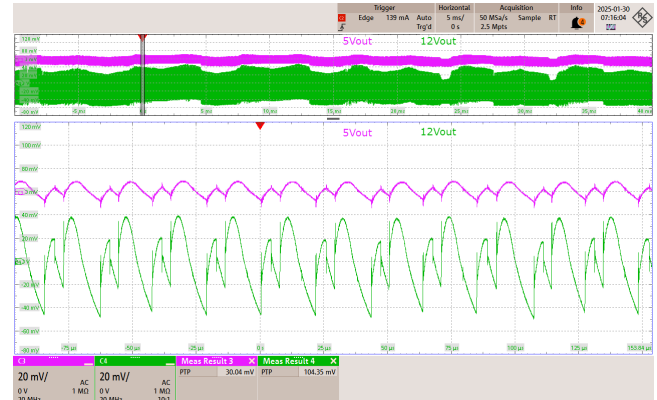

Figure 104 – 115 VAC 60 Hz.

CH3: 5 V_Output Ripple, 20 mV / div., 5 ms / div.
 CH4: 12 V_Output Ripple, 20 mV / div., 5 ms / div.
 Zoom: 25 μ s / div.
 5 V_Output Ripple = 30 mV
 12 V_Output Ripple = 105 mV

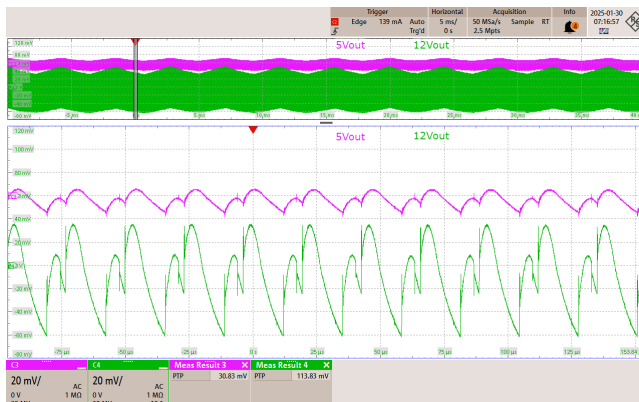

Figure 105 – 230 VAC 50 Hz.

CH3: 5 V_Output Ripple, 20 mV / div., 5 ms / div.
 CH4: 12 V_Output Ripple, 20 mV / div., 5 ms / div.
 Zoom: 25 μ s / div.
 5 V_Output Ripple = 30.8 mV
 12 V_Output Ripple = 114 mV

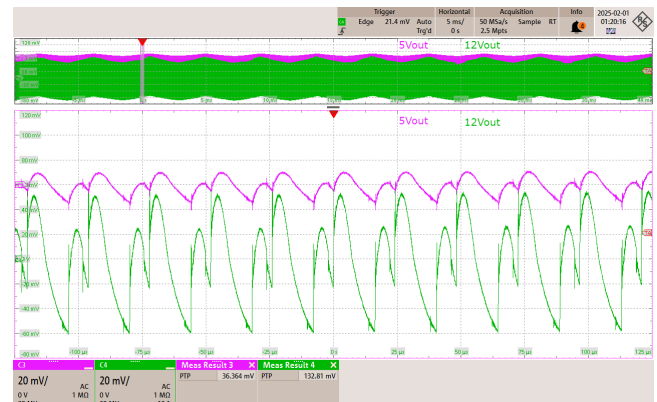

Figure 106 – 265 VAC 50 Hz.

CH3: 5 V_Output Ripple, 20 mV / div., 5 ms / div.
 CH4: 12 V_Output Ripple, 20 mV / div., 5 ms / div.
 Zoom: 25 μ s / div.
 5 V_Output Ripple = 36.4 mV
 12 V_Output Ripple = 133 mV

10.3.2.2 75% Load Condition

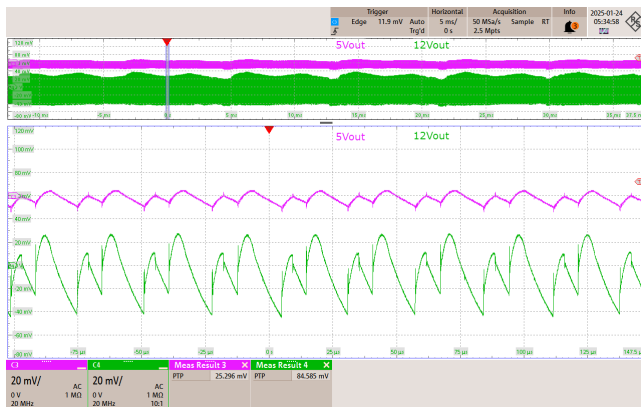

Figure 107 – 85 VAC 60 Hz.

CH3: 5 V_Output Ripple, 20 mV / div., 5 ms / div.
 CH4: 12 V_Output Ripple, 20 mV / div., 5 ms / div.
 Zoom: 25 μ s / div.
 5 V_Output Ripple = 25.3 mV
 12 V_Output Ripple = 84.6 mV

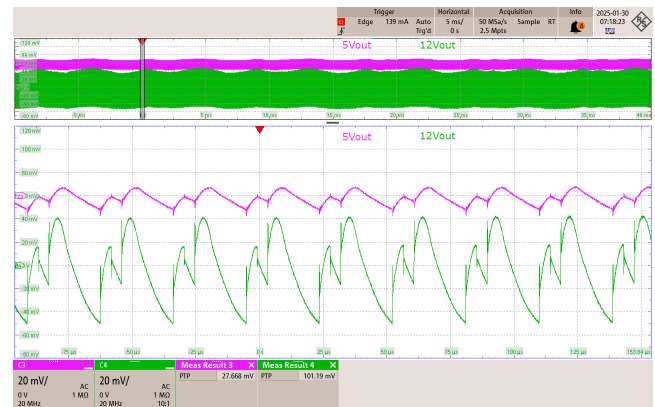

Figure 108 – 115 VAC 60 Hz.

CH3: 5 V_Output Ripple, 20 mV / div., 5 ms / div.
 CH4: 12 V_Output Ripple, 20 mV / div., 5 ms / div.
 Zoom: 25 μ s / div.
 5 V_Output Ripple = 27.7 mV
 12 V_Output Ripple = 101 mV

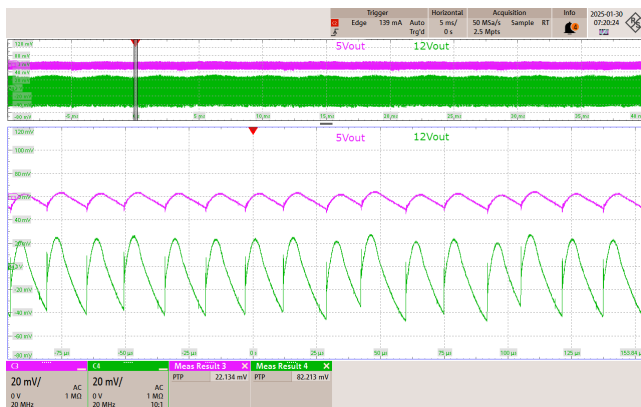

Figure 109 – 230 VAC 50 Hz.

CH3: 5 V_Output Ripple, 20 mV / div., 5 ms / div.
 CH4: 12 V_Output Ripple, 20 mV / div., 5 ms / div.
 Zoom: 25 μ s / div.
 5 V_Output Ripple = 22.1 mV
 12 V_Output Ripple = 82.2 mV

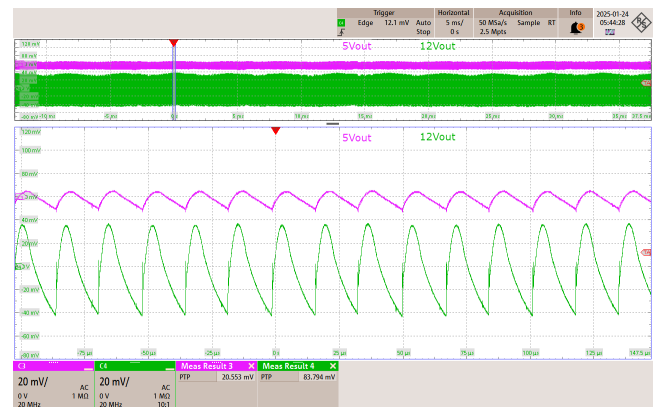

Figure 110 – 265 VAC 50 Hz.

CH3: 5 V_Output Ripple, 20 mV / div., 5 ms / div.
 CH4: 12 V_Output Ripple, 20 mV / div., 5 ms / div.
 Zoom: 25 μ s / div.
 5 V_Output Ripple = 20.3 mV
 12 V_Output Ripple = 83.8 mV

10.3.2.3 50% Load Condition

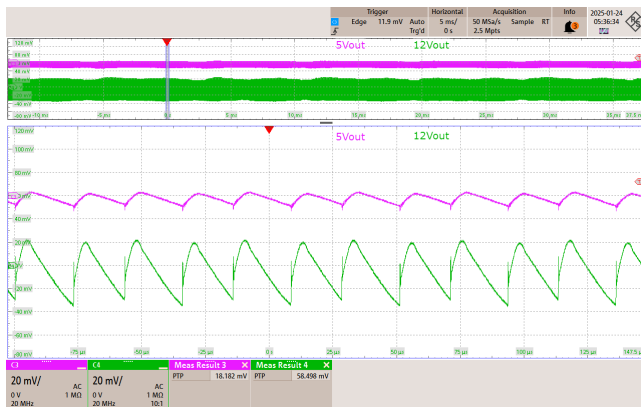

Figure 111 – 85 VAC 60 Hz.

CH3: 5 V_Output Ripple, 20 mV / div., 5 ms / div.
 CH4: 12 V_Output Ripple, 20 mV / div., 5 ms / div.
 Zoom: 25 μ s / div.
 5 V_Output Ripple = 18.2 mV
 12 V_Output Ripple = 58.5 mV

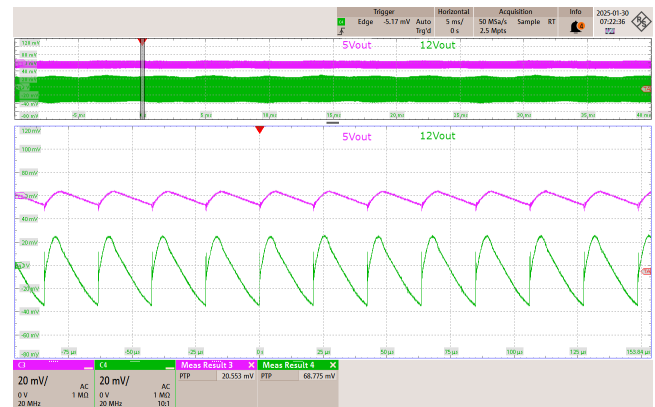

Figure 112 – 115 VAC 60 Hz.

CH3: 5 V_Output Ripple, 20 mV / div., 5 ms / div.
 CH4: 12 V_Output Ripple, 20 mV / div., 5 ms / div.
 Zoom: 25 μ s / div.
 5 V_Output Ripple = 20.6 mV
 12 V_Output Ripple = 68.8 mV

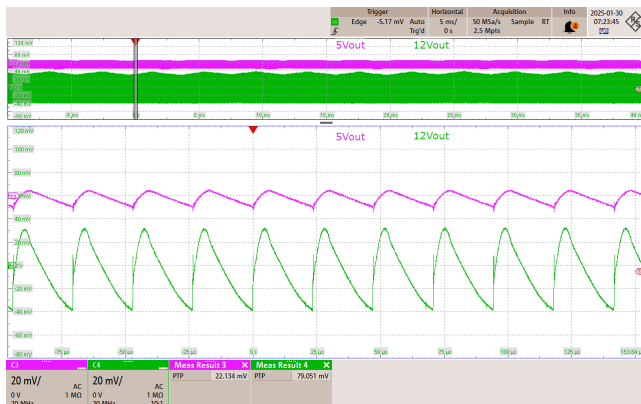

Figure 113 – 230 VAC 50 Hz.

CH3: 5 V_Output Ripple, 20 mV / div., 5 ms / div.
 CH4: 12 V_Output Ripple, 20 mV / div., 5 ms / div.
 Zoom: 25 μ s / div.
 5 V_Output Ripple = 22.1 mV
 12 V_Output Ripple = 79.1 mV

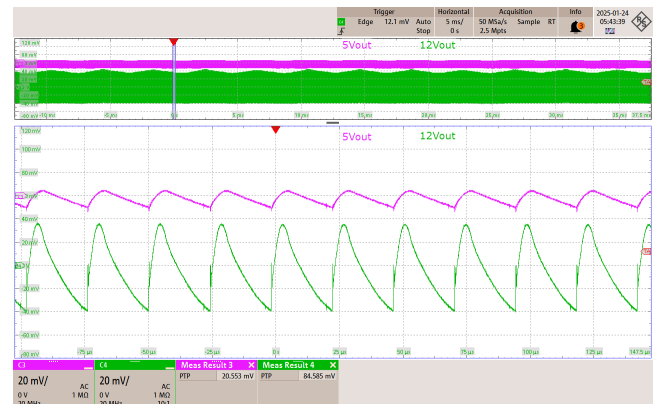

Figure 114 – 265 VAC 50 Hz.

CH3: 5 V_Output Ripple, 20 mV / div., 5 ms / div.
 CH4: 12 V_Output Ripple, 20 mV / div., 5 ms / div.
 Zoom: 25 μ s / div.
 5 V_Output Ripple = 20.5 mV
 12 V_Output Ripple = 84.6 mV

10.3.2.4 25% Load Condition

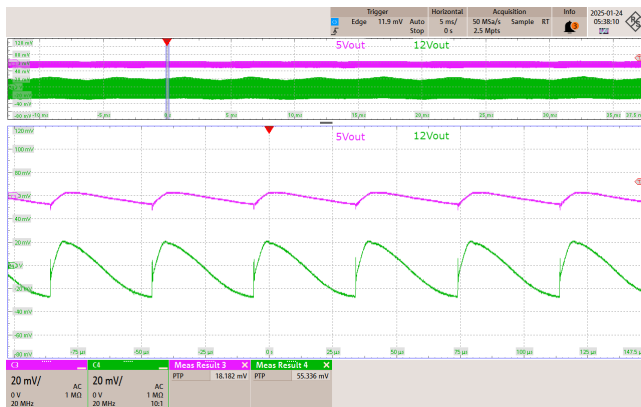

Figure 115 – 85 VAC 60 Hz.

CH3: 5 V_Output Ripple, 20 mV / div., 5 ms / div.
 CH4: 12 V_Output Ripple, 20 mV / div., 5 ms / div.
 Zoom: 25 μ s / div.
 5 V_Output Ripple = 18.2 mV
 12 V_Output Ripple = 55.3 mV

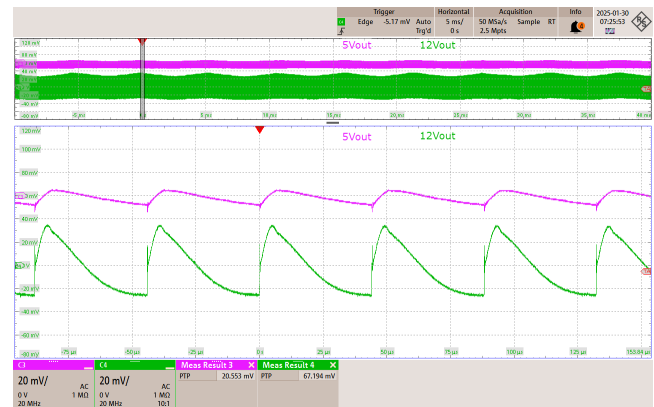

Figure 116 – 115 VAC 60 Hz.

CH3: 5 V_Output Ripple, 20 mV / div., 5 ms / div.
 CH4: 12 V_Output Ripple, 20 mV / div., 5 ms / div.
 Zoom: 25 μ s / div.
 5 V_Output Ripple = 20.6 mV
 12 V_Output Ripple = 67.2 mV

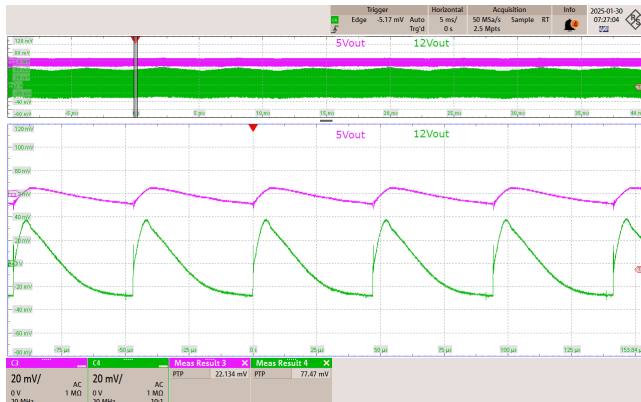

Figure 117 – 230 VAC 50 Hz.

CH3: 5 V_Output Ripple, 20 mV / div., 5 ms / div.
 CH4: 12 V_Output Ripple, 20 mV / div., 5 ms / div.
 Zoom: 25 μ s / div.
 5 V_Output Ripple = 22.1 mV
 12 V_Output Ripple = 77.5 mV

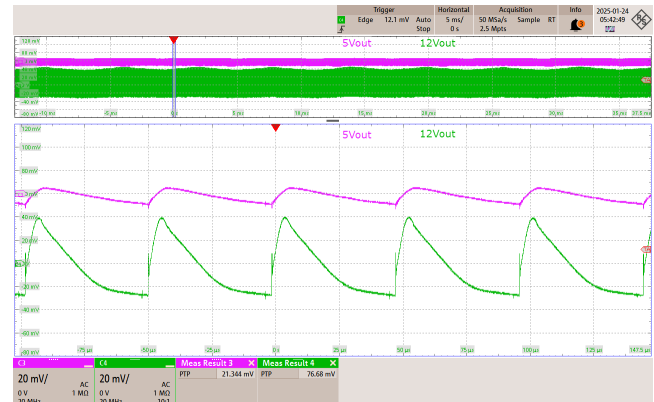

Figure 118 – 265 VAC 50 Hz.

CH3: 5 V_Output Ripple, 20 mV / div., 5 ms / div.
 CH4: 12 V_Output Ripple, 20 mV / div., 5 ms / div.
 Zoom: 25 μ s / div.
 5 V_Output Ripple = 21.3 mV
 12 V_Output Ripple = 76.6 mV

10.3.2.5 10% Load Condition

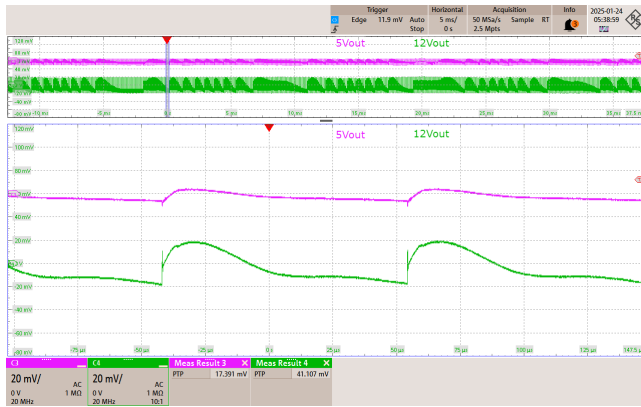

Figure 119 – 85 VAC 60 Hz.

CH3: 5 V_Output Ripple, 20 mV / div., 5 ms / div.
 CH4: 12 V_Output Ripple, 20 mV / div., 5 ms / div.
 Zoom: 25 μ s / div.
 5 V_Output Ripple = 17.4 mV
 12 V_Output Ripple = 41.1 mV

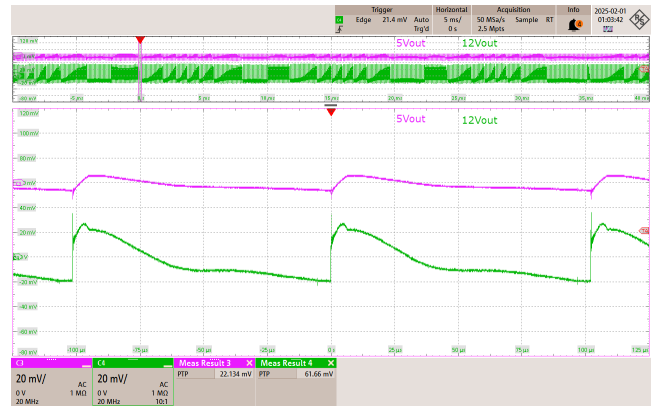

Figure 120 – 115 VAC 60 Hz.

CH3: 5 V_Output Ripple, 20 mV / div., 5 ms / div.
 CH4: 12 V_Output Ripple, 20 mV / div., 5 ms / div.
 Zoom: 25 μ s / div.
 5 V_Output Ripple = 22.1 mV
 12 V_Output Ripple = 61.7 mV

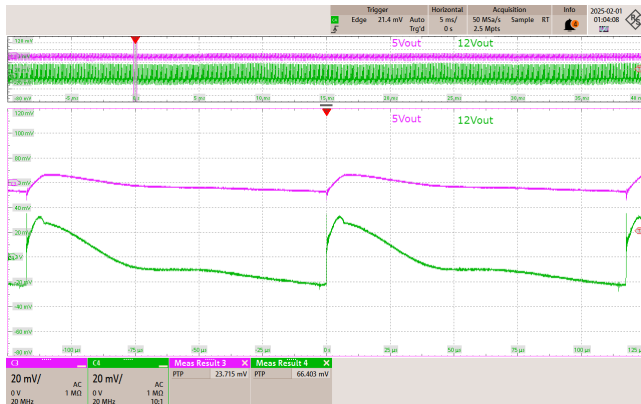

Figure 121 – 230 VAC 50 Hz.

CH3: 5 V_Output Ripple, 20 mV / div., 5 ms / div.
 CH4: 12 V_Output Ripple, 20 mV / div., 5 ms / div.
 Zoom: 25 μ s / div.
 5 V_Output Ripple = 23.7 mV
 12 V_Output Ripple = 66.4 mV

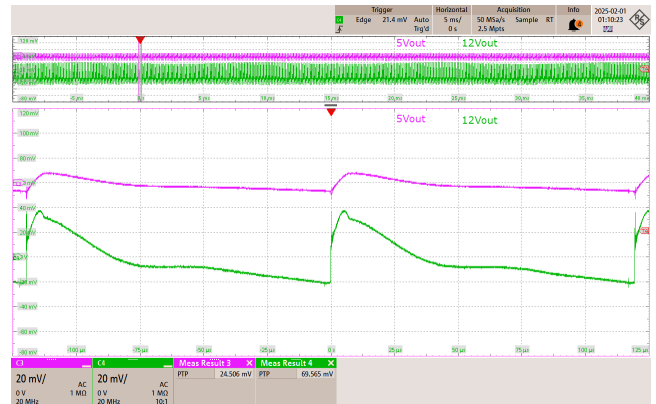

Figure 122 – 265 VAC 50 Hz.

CH3: 5 V_Output Ripple, 20 mV / div., 5 ms / div.
 CH4: 12 V_Output Ripple, 20 mV / div., 5 ms / div.
 Zoom: 25 μ s / div.
 5 V_Output Ripple = 24.5 mV
 12 V_Output Ripple = 69.6 mV

10.3.3 Output Ripple Voltage Graph

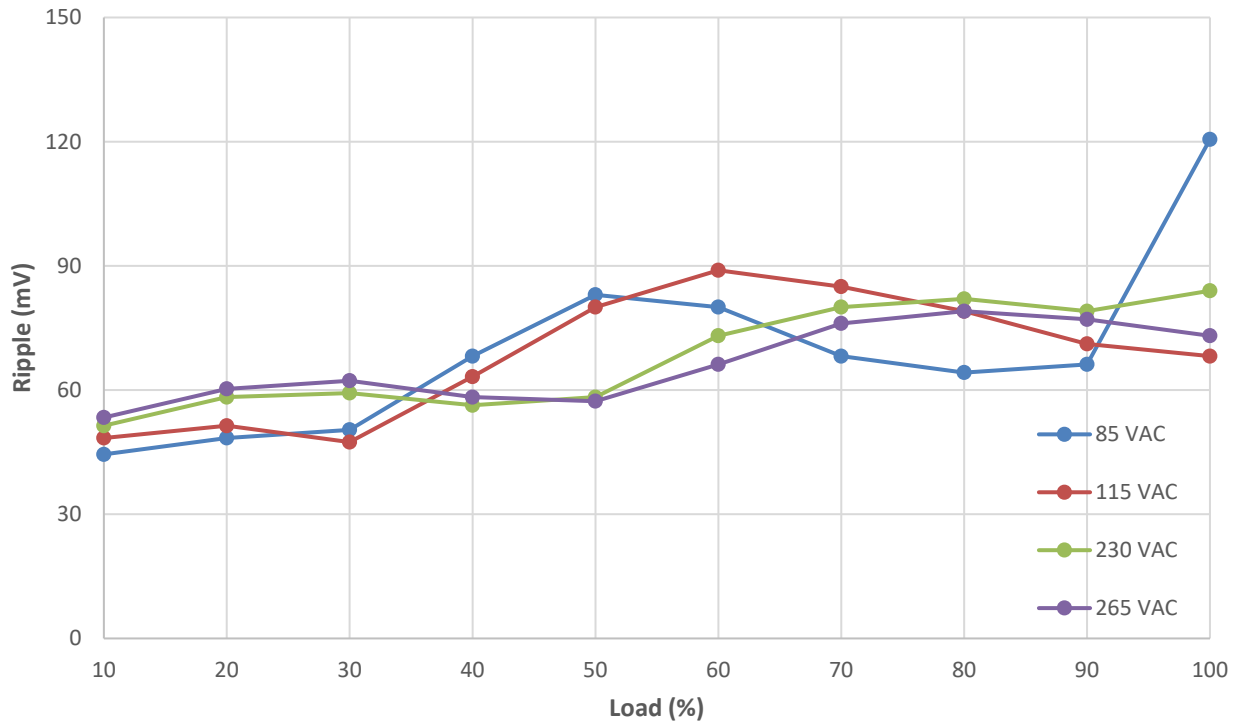

Figure 123 – 12 Voltage Ripple (Measured at PCB End at Room Temperature).

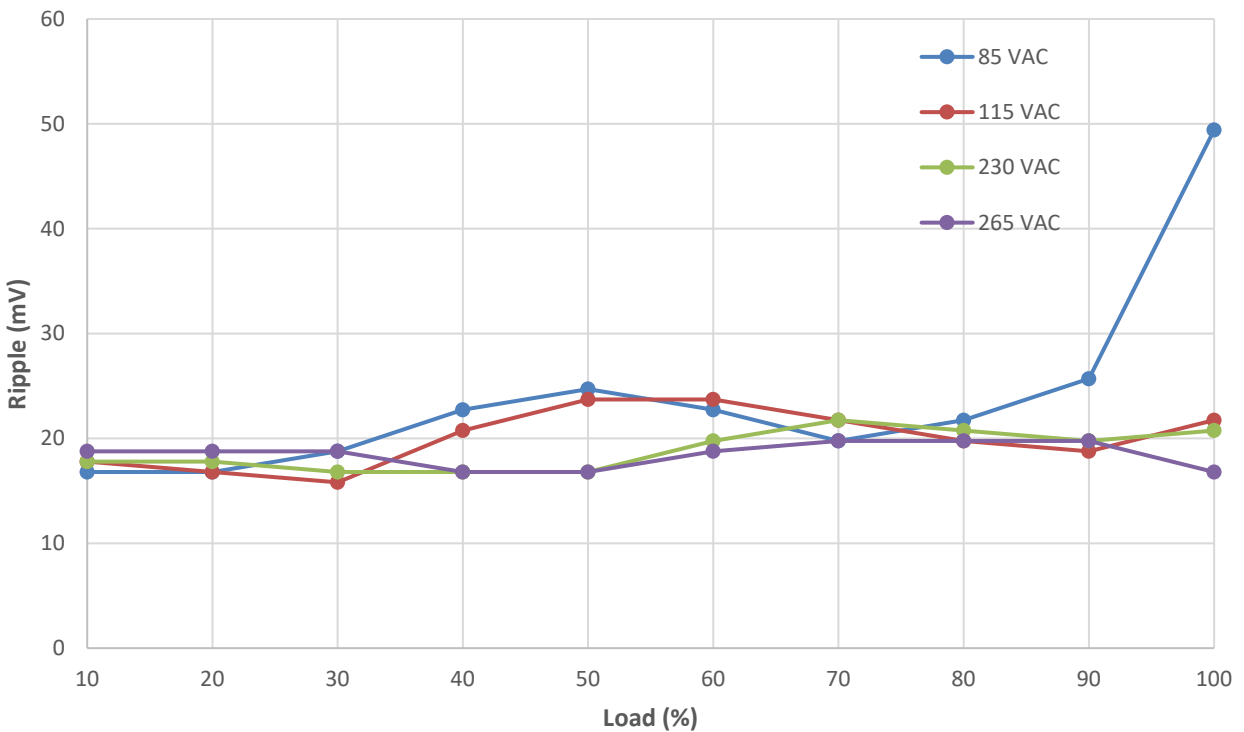

Figure 124 – 5 Voltage Ripple (Measured at PCB End at Room Temperature).

10.4 Thermal Performance

10.4.1 85 VAC Full Load at 25 °C Ambient

Test result after 60 minutes running continuously inside an enclosure at 85 VAC full load using FLIR thermal camera to measure component temperatures.

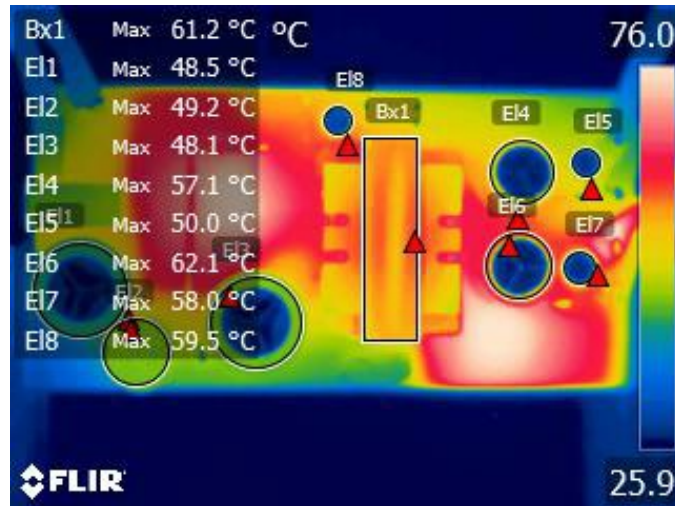

Figure 125 – 85 VAC 60 Hz Top Side Discrete Component Thermals.

Component	Temperature (°C)
Ambient	25.9
Transformer Core (T1)	61.2
Input Capacitor 1(Cin19)	48.5
Diff. Mode Choke (L4)	49.2
Input Capacitor 2 (Cin2)	48.1
12 V _{OUT} Output Capacitor 1(Cout9)	57.1
12 V _{OUT} Output Capacitor 2(Cout10)	50.0
5 V _{OUT} Output Capacitor 1(Cout12)	62.1
5 V _{OUT} Output Capacitor 2(Cout13)	58.0
Bias Capacitor (C4)	59.5

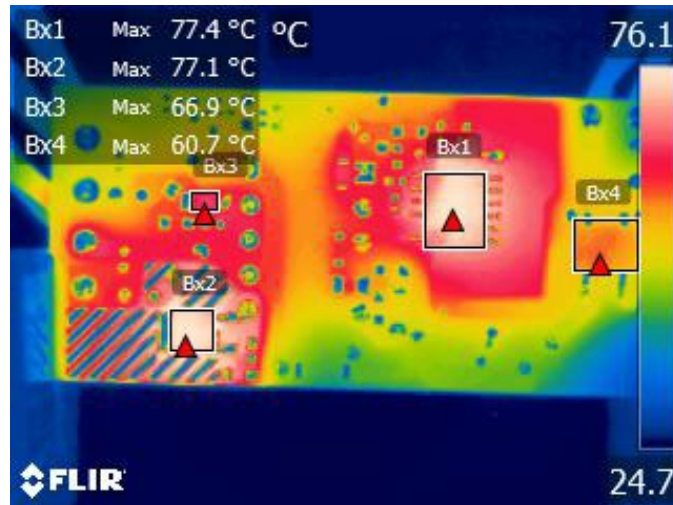

Figure 126 – 85 VAC 60 Hz Bottom Side Thermals.

Component	Temperature (°C)
Ambient	24.7
TNY50732K (U41)	77.4
12 V Secondary Diode (D4)	77.1
5 V Secondary Diode (D5)	66.9
BR Diode (BR2)	60.7

10.4.2 265 VAC Full Load at 25 °C Ambient

Test result after 60 minutes running continuously inside thermal chamber at 265 VAC full load using FLIR thermal camera to measure component temperatures.

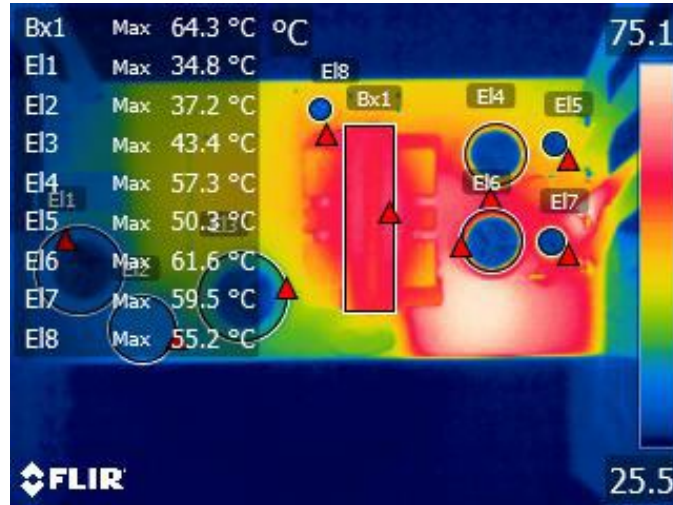

Figure 127 – 265 VAC 50 Hz Top Side Discrete Component Thermals.

Component	Temperature (°C)
Ambient	25.5
Transformer Core (T1)	64.3
Input Capacitor 1(Cin19)	34.8
Diff. Mode Choke (L4)	37.2
Input Capacitor 2 (Cin2)	43.4
12 V _{OUT} Output Capacitor 1(Cout9)	57.3
12 V _{OUT} Output Capacitor 2(Cout10)	50.3
5 V _{OUT} Output Capacitor 1(Cout12)	61.6
5 V _{OUT} Output Capacitor 2(Cout13)	59.5
Bias Capacitor (C4)	55.2

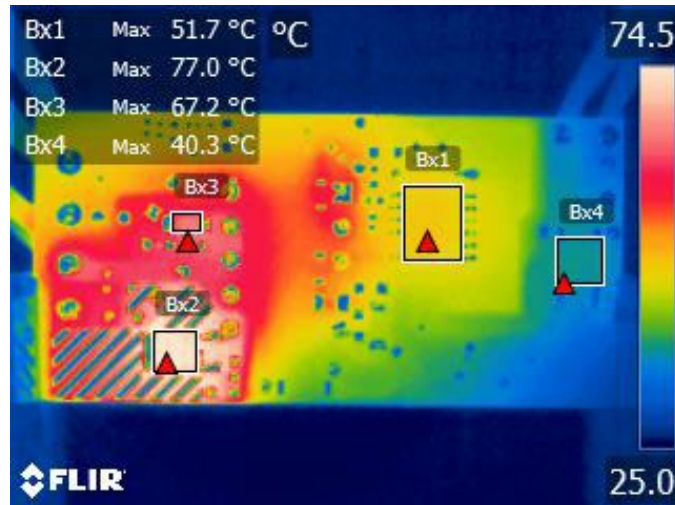

Figure 128 – 265 VAC 50 Hz Bottom Side Thermals.

Component	Temperature (°C)
Ambient	25.0
TNY50732K (U41)	51.7
12 V Secondary Diode (D4)	77.0
5 V Secondary Diode (D5)	67.2
BR Diode (BR2)	40.3

11 Fault Condition

11.1 Output Short-Circuit Protection

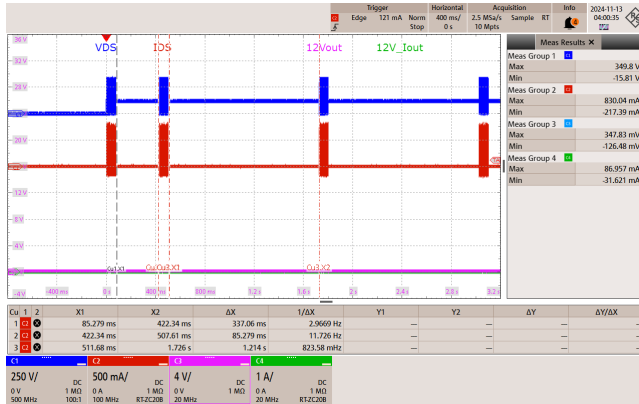

Figure 129 – 85 VAC 60 Hz 12 V Start-Up Output Short.

CH1: Drain Voltage, 250 V / div., 400 ms / div.
 CH2: Drain Current, 500 mA / div., 400 ms / div.
 CH3: 12 V_VOUT, 4 V / div., 400 ms / div.
 CH4: 12 V_IOUT, 1 A / div., 400 ms / div.

Drain Voltage (MAX) = 350 V
 Drain Current (MAX) = 830 mA
 $t_{AR(OFF)1}$ = 337 ms
 $t_{AR(OFF)2}$ = 1.21 s
 $t_{AR(ON)}$ = 85.3 ms



Figure 130 – 265 VAC 50 Hz 12 V Start-Up Output Short.

CH1: Drain Voltage, 250 V / div., 400 ms / div.
 CH2: Drain Current, 500 mA / div., 400 ms / div.
 CH3: 12V_VOUT, 4 V / div., 400 ms / div.
 CH4: 12V_IOUT, 1 A / div., 400 ms / div.

Drain Voltage (MAX) = 597 V
 Drain Current (MAX) = 909 mA
 $t_{AR(OFF)1}$ = 345 ms
 $t_{AR(OFF)2}$ = 1.21 s
 $t_{AR(ON)}$ = 142 ms

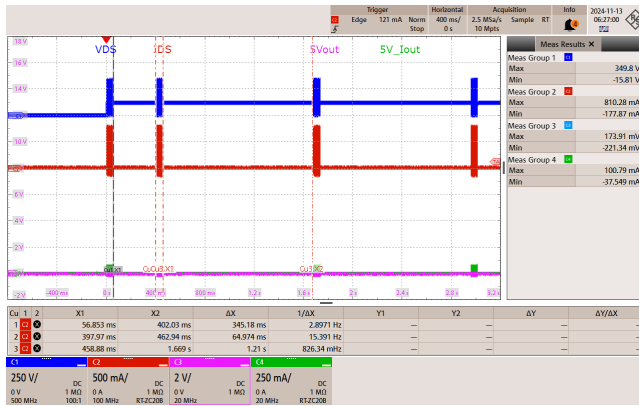

Figure 131 – 85 VAC 60 Hz 5 V Start-Up Output Short.
 CH1: Drain Voltage, 250 V / div., 400 ms / div.
 CH2: Drain Current, 500 mA / div., 400 ms / div.
 CH3: 5 V_Vout, 2 V / div., 400 ms / div.
 CH4: 5 V_Iout, 250 mA / div., 400 ms / div.
 Drain Voltage (MAX) = 350 V
 Drain Current (MAX) = 810 mA
 $t_{AR(OFF)1}$ = 345 ms
 $t_{AR(OFF)2}$ = 1.21 s
 $t_{AR(ON)}$ = 65 ms

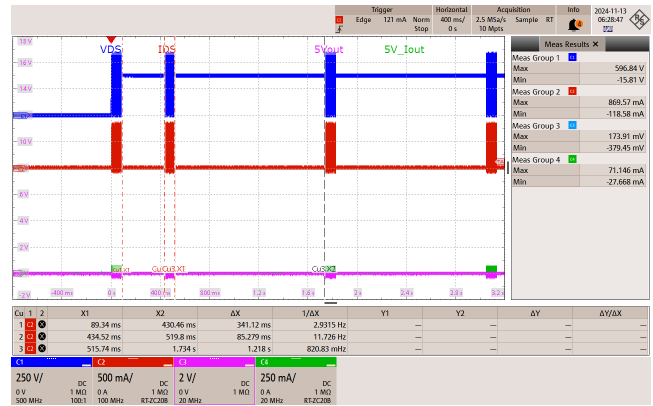

Figure 132 – 265 VAC 50 Hz 5 V Start-Up Output Short.
 CH1: Drain Voltage, 250 V / div., 400 ms / div.
 CH2: Drain Current, 500 mA / div., 400 ms / div.
 CH3: 5 V_Vout, 2 V / div., 400 ms / div.
 CH4: 5 V_Iout, 250 mA / div., 400 ms / div.
 Drain Voltage (MAX) = 597 V
 Drain Current (MAX) = 870 mA
 $t_{AR(OFF)1}$ = 341 ms
 $t_{AR(OFF)2}$ = 1.22 s
 $t_{AR(ON)}$ = 85.2 ms

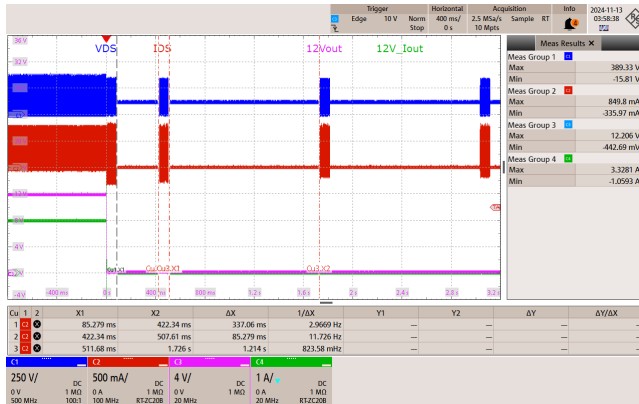

Figure 133 – 85 VAC 60 Hz 12 V Running Output Short.
 CH1: Drain Voltage, 250 V / div., 400 ms / div.
 CH2: Drain Current, 500 mA / div., 400 ms / div.
 CH3: 12 V_Vout, 4 V / div., 400 ms / div.
 CH4: 12 V_Iout, 1 A / div., 400 ms / div.
 Drain Voltage (MAX) = 389 V
 Drain Current (MAX) = 850 mA
 $t_{AR(OFF)1}$ = 337 ms
 $t_{AR(OFF)2}$ = 1.21 s
 $t_{AR(ON)}$ = 85.3 ms

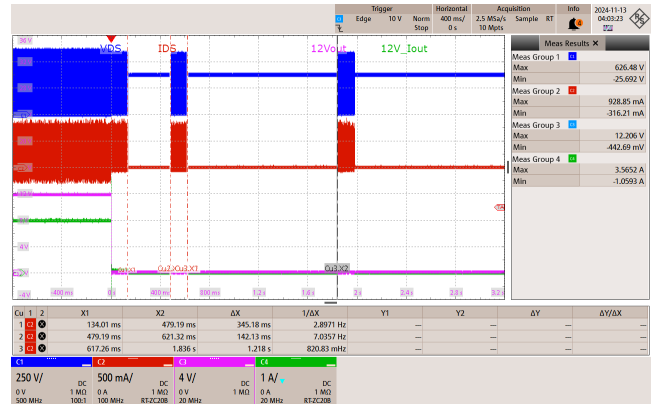

Figure 134 – 265 VAC 50 Hz 12 V Running Output Short.
 CH1: Drain Voltage, 250 V / div., 400 ms / div.
 CH2: Drain Current, 500 mA / div., 400 ms / div.
 CH3: 12 V_Vout, 4 V / div., 400 ms / div.
 CH4: 12 V_Iout, 1 A / div., 400 ms / div.
 Drain Voltage (MAX) = 626 V
 Drain Current (MAX) = 929 mA
 $t_{AR(OFF)1}$ = 345 ms
 $t_{AR(OFF)2}$ = 1.22 s
 $t_{AR(ON)}$ = 142 ms

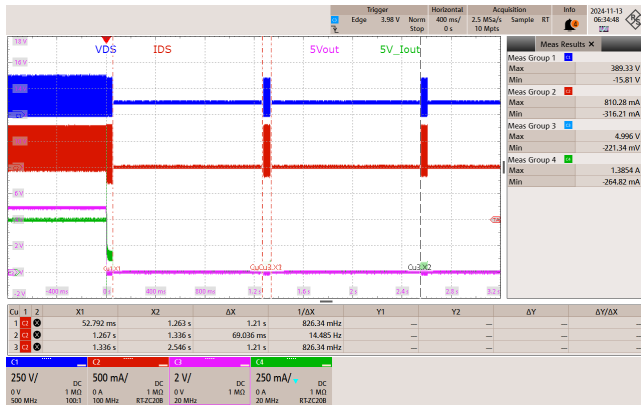

Figure 135 – 85 VAC 60 Hz 5 V Running Output Short.
 CH1: Drain Voltage, 250 V / div., 400 ms / div.
 CH2: Drain Current, 500 mA / div., 400 ms / div.
 CH3: 5 V_V_{OUT}, 2 V / div., 400 ms / div.
 CH4: 5 V_I_{OUT}, 250 mA / div., 400 ms / div.
 Drain Voltage (MAX) = 389 V
 Drain Current (MAX) = 810 mA
 t_{AR(OFF)1} = 1.21 s
 t_{AR(OFF)2} = 1.21 s
 t_{AR(ON)} = 69 ms

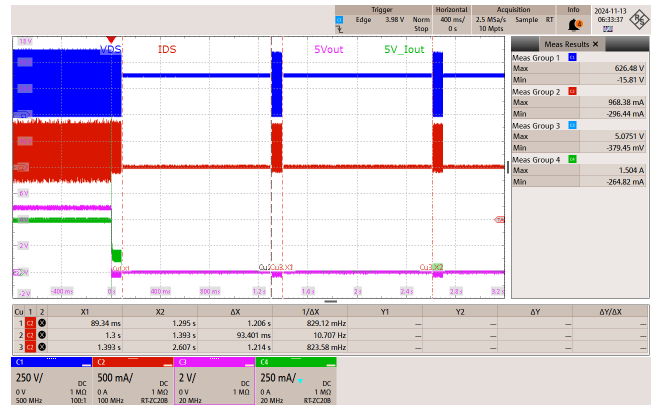

Figure 136 – 265 VAC 50 Hz 5 V Running Output Short.
 CH1: Drain Voltage, 250 V / div., 400 ms / div.
 CH2: Drain Current, 500 mA / div., 400 ms / div.
 CH3: 5 V_V_{OUT}, 2 V / div., 400 ms / div.
 CH4: 5 V_I_{OUT}, 250 mA / div., 400 ms / div.
 Drain Voltage (MAX) = 626 V
 Drain Current (MAX) = 968 mA
 t_{AR(OFF)1} = 1.21 s
 t_{AR(OFF)2} = 1.21 s
 t_{AR(ON)} = 93.4 ms

11.2 Overpower Protection

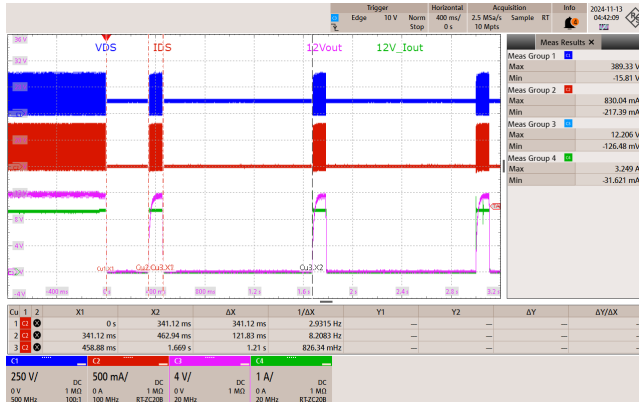

Figure 137 – 85 VAC 60 Hz 12 V / 2.3 A, 5 V / 0.575 A.
 CH1: Drain Voltage, 250 V / div., 400 ms / div.
 CH2: Drain Current, 500 mA / div., 400 ms / div.
 CH3: 12 V_V_{OUT}, 4 V / div., 400 ms / div.
 CH4: 12 V_I_{OUT}, 1 A / div., 400 ms / div.
 Drain Voltage (MAX) = 389 V
 Drain Current (MAX) = 830 mA
 $t_{AR(OFF)1}$ = 341 ms
 $t_{AR(OFF)2}$ = 1.24 s
 $t_{AR(ON)}$ = 122 ms



Figure 138 – 265 VAC 60 Hz. 12 V / 3.5 A, 5 V / 0.875 A.
 CH1: Drain Voltage, 250 V / div., 400 ms / div.
 CH2: Drain Current, 500 mA / div., 400 ms / div.
 CH3: 12 V_V_{OUT}, 4 V / div., 400 ms / div.
 CH4: 12 V_I_{OUT}, 1 A / div., 400 ms / div.
 Drain Voltage (MAX) = 636 V
 Drain Current (MAX) = 1.01 A
 $t_{AR(OFF)1}$ = 341 ms
 $t_{AR(OFF)2}$ = 1.22 s
 $t_{AR(ON)}$ = 97.5 ms

11.3 Over Temperature Protection

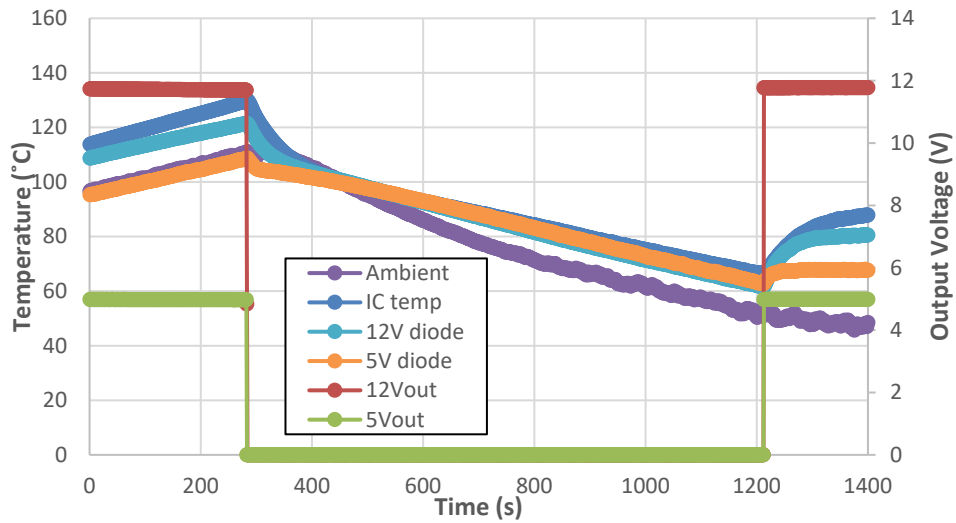

Figure 139 – 85 VAC 60 Hz Full Load OTP.

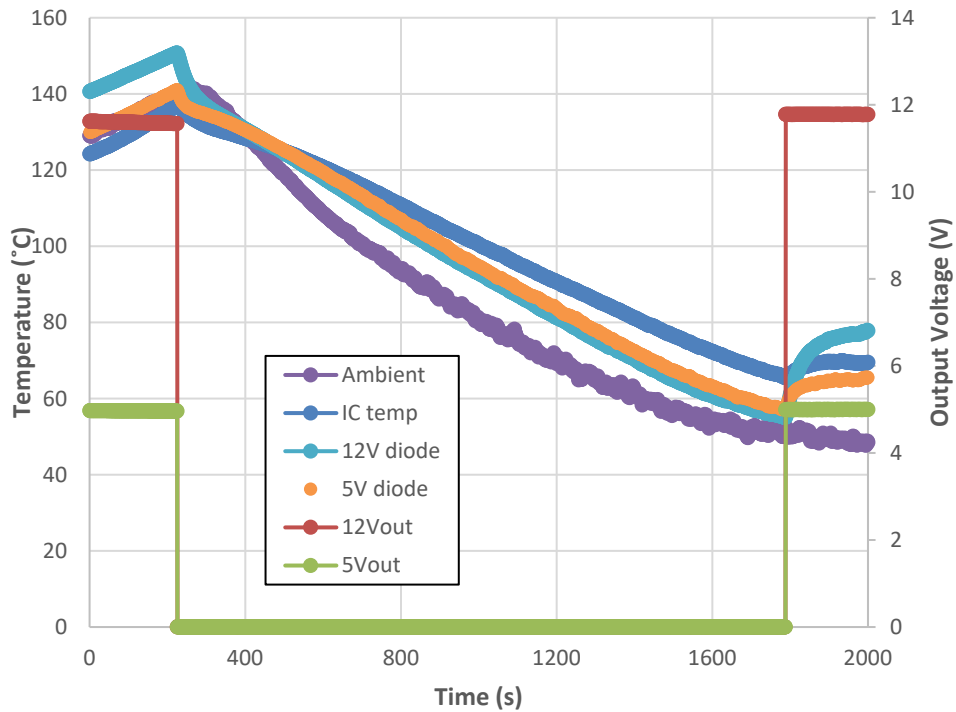

Figure 140 – 265 VAC 50 Hz Full Load OTP.

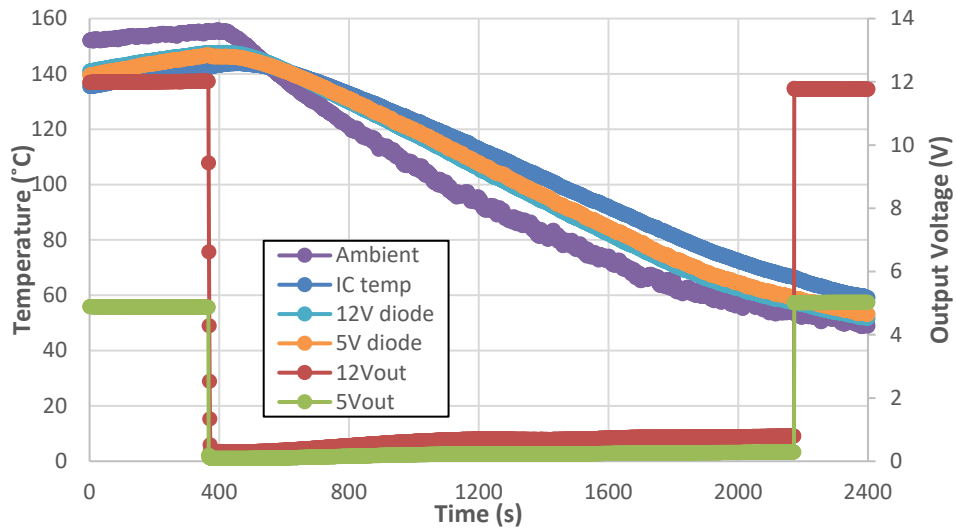

Figure 141 – 85 VAC 60 Hz No Load OTP.

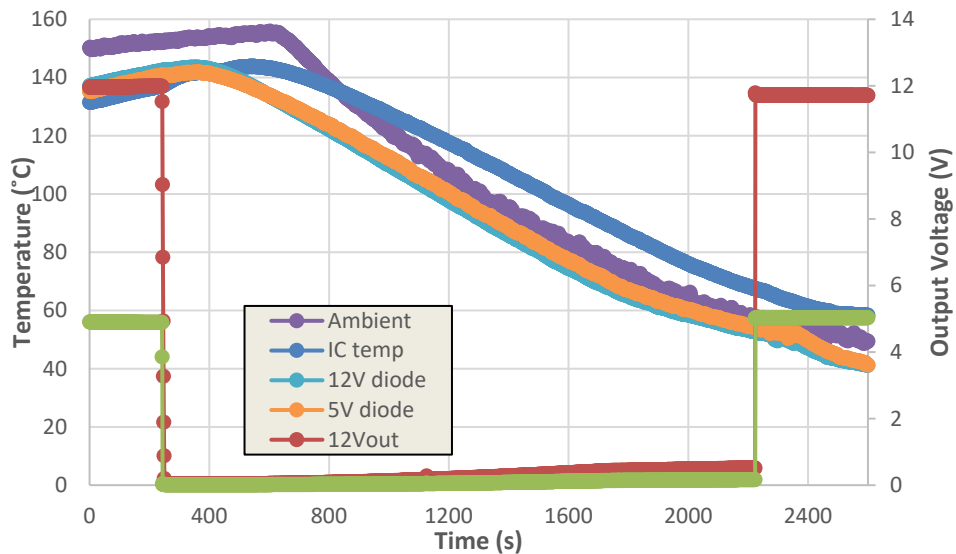

Figure 142 – 265 VAC 50 Hz No Load OTP.

Input (VAC) and Loading	IC Temperature (°C)	
	OTP Shutdown	Recover
85 VAC Full Load	123	66.4
265 VAC Full Load	137	65.5
85 VAC No Load	142	66.4
265 VAC No Load	137	67.4



12 Conducted EMI

Conducted emissions tests were performed at 115 VAC and 230 VAC at full load (12 V / 2 A and 5 V / 0.5 A). Measurements were taken with floating ground.

12.1 Test Set-up Equipment

12.1.1 Equipment and Load Used

1. Rohde and Schwarz ENV216 two-line V-network.
2. Rohde and Schwarz ESRP EMI test receiver.
3. Input voltage set at 115 VAC and 230 VAC.
4. 12 V R_{LOAD} resistance is 6 Ohms and 5 V R_{LOAD} resistance is 10 Ohms.

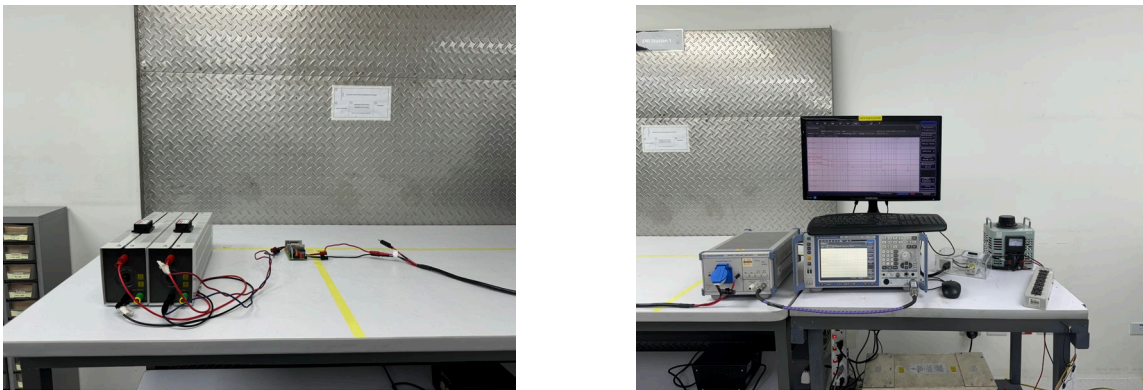

Figure 143 – EMI Test Set-up.

12.2 Output Float

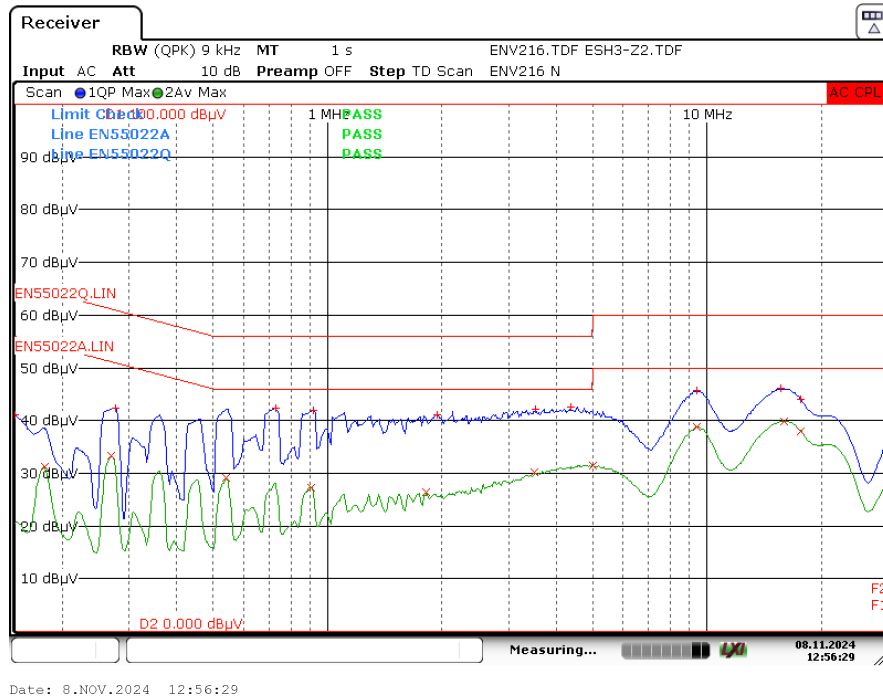

Figure 144 – 115 VAC 50 Hz.
Line / Neutral - Floating

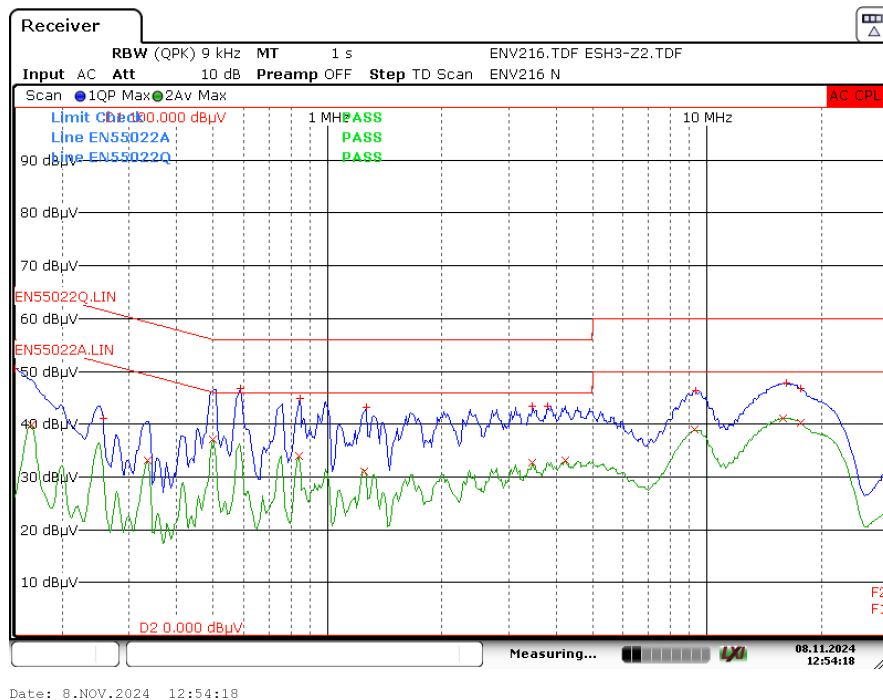

Figure 145 – 230 VAC 50 Hz.
Line / Neutral - Floating

13 Line Surge

IEC61000-4-5 differential mode and common mode input line surge testing was completed on a single test unit. Input voltage was set at 230 VAC / 60 Hz output was loaded at full load and operation was verified following each surge event.

13.1 Differential Mode Surge

DM Surge Level (kV)	Input Voltage (VAC)	Injection Location	Injection Phase (°)	Test Result (Pass/Fail)
+1	115	L to N	0	Pass
-1	115	L to N	0	Pass
+1	115	L to N	90	Pass
-1	115	L to N	90	Pass
+1	115	L to N	180	Pass
-1	115	L to N	180	Pass
+1	115	L to N	270	Pass
-1	115	L to N	270	Pass

Note: In all PASS results, power supply is still functional after the test.

DM Surge Level (kV)	Input Voltage (VAC)	Injection Location	Injection Phase (°)	Test Result (Pass/Fail)
+1	230	L to N	0	Pass
-1	230	L to N	0	Pass
+1	230	L to N	90	Pass
-1	230	L to N	90	Pass
+1	230	L to N	180	Pass
-1	230	L to N	180	Pass
+1	230	L to N	270	Pass
-1	230	L to N	270	Pass

Note: In all PASS results, power supply is still functional after the test.

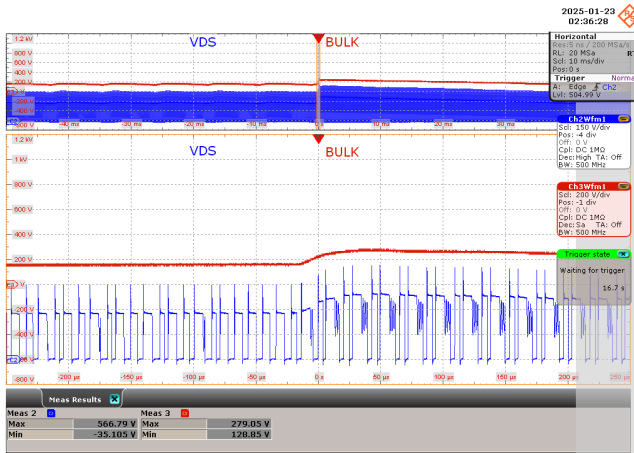

Figure 146 – 115 VAC 60 Hz +1kV_90°
 CH2: Drain Voltage, 150 V / div., 10 ms / div.
 CH3: Bulk Voltage, 200 V / div., 10 ms / div.
 Zoom: 50 µs / div
 V_{DS} Max Voltage = 567 V.

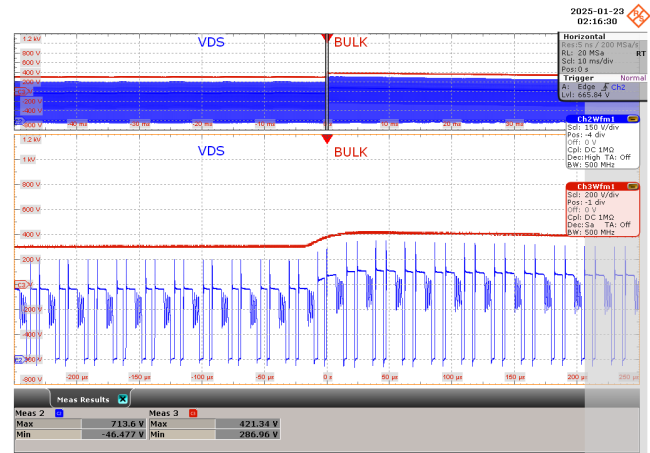

Figure 147 – 230 VAC 60 Hz +1kV_90°
 CH2: Drain Voltage, 150 V / div., 10 ms / div.
 CH3: Bulk Voltage, 200 V / div., 10 ms / div.
 Zoom: 50 µs / div
 V_{DS} Max Voltage = 714 V.

13.2 Common Mode Surge – Ring Wave

Surge Voltage (kV)	Phase Angle (°)	Input Voltage (VAC)	IEC Coupling	Generator Impedance (W)	Number of Strikes	Result
+4	0	115	L, N - PE	12	10	PASS
-4	0	115	L, N - PE	12	10	PASS
+4	90	115	L, N - PE	12	10	PASS
-4	90	115	L, N - PE	12	10	PASS
+4	270	115	L, N - PE	12	10	PASS
-4	270	115	L, N - PE	12	10	PASS

Note: In all PASS results, power supply is still functional after the test.

Surge Voltage (kV)	Phase Angle (°)	Input Voltage (VAC)	IEC Coupling	Generator Impedance (W)	Number of Strikes	Result
+4	0	230	L, N - PE	12	10	PASS
-4	0	230	L, N - PE	12	10	PASS
+4	90	230	L, N - PE	12	10	PASS
-4	90	230	L, N - PE	12	10	PASS
+4	270	230	L, N - PE	12	10	PASS
-4	270	230	L, N - PE	12	10	PASS

Note: In all PASS results, power supply is still functional after the test.

13.3 EFT Burst

EFT DM Surge Level (kV)	Input Voltage (VAC)	Injection Location	Injection Phase (°)	Frequency	T-Burst	T-Rep	Test Duration	Test Result
+4	115	L to N	0	5 kHz	15 ms	300 ms	120 s	Pass
-4	115	L to N	0	5 kHz	15 ms	300 ms	120 s	Pass
+4	115	L to N	0	100 kHz	750 μ s	300 ms	120 s	Pass
-4	115	L to N	0	100 kHz	750 μ s	300 ms	120 s	Pass
+4	115	L to N	90	5 kHz	15 ms	300 ms	120 s	Pass
-4	115	L to N	90	5 kHz	15 ms	300 ms	120 s	Pass
+4	115	L to N	90	100 kHz	750 μ s	300 ms	120 s	Pass
-4	115	L to N	90	100 kHz	750 μ s	300 ms	120 s	Pass
+4	115	L to N	180	5 kHz	15 ms	300 ms	120 s	Pass
-4	115	L to N	180	5 kHz	15 ms	300 ms	120 s	Pass
+4	115	L to N	180	100 kHz	750 μ s	300 ms	120 s	Pass
-4	115	L to N	180	100 kHz	750 μ s	300 ms	120 s	Pass
+4	115	L to N	270	5 kHz	15 ms	300 ms	120 s	Pass
-4	115	L to N	270	5 kHz	15 ms	300 ms	120 s	Pass
+4	115	L to N	270	100 kHz	750 μ s	300 ms	120 s	Pass
-4	115	L to N	270	100 kHz	750 μ s	300 ms	120 s	Pass

EFT DM Surge Level (kV)	Input Voltage (VAC)	Injection Location	Injection Phase (°)	Frequency	T-Burst	T-Rep	Test Duration	Test Result
+4	230	L to N	0	5 kHz	15 ms	300 ms	120 s	Pass
-4	230	L to N	0	5 kHz	15 ms	300 ms	120 s	Pass
+4	230	L to N	0	100 kHz	750 μ s	300 ms	120 s	Pass
-4	230	L to N	0	100 kHz	750 μ s	300 ms	120 s	Pass
+4	230	L to N	90	5 kHz	15 ms	300 ms	120 s	Pass
-4	230	L to N	90	5 kHz	15 ms	300 ms	120 s	Pass
+4	230	L to N	90	100 kHz	750 μ s	300 ms	120 s	Pass
-4	230	L to N	90	100 kHz	750 μ s	300 ms	120 s	Pass
+4	230	L to N	180	5 kHz	15 ms	300 ms	120 s	Pass
-4	230	L to N	180	5 kHz	15 ms	300 ms	120 s	Pass
+4	230	L to N	180	100 kHz	750 μ s	300 ms	120 s	Pass
-4	230	L to N	180	100 kHz	750 μ s	300 ms	120 s	Pass
+4	230	L to N	270	5 kHz	15 ms	300 ms	120 s	Pass
-4	230	L to N	270	5 kHz	15 ms	300 ms	120 s	Pass
+4	230	L to N	270	100 kHz	750 μ s	300 ms	120 s	Pass
-4	230	L to N	270	100 kHz	750 μ s	300 ms	120 s	Pass



14 ESD

All ESD strikes were applied at end of PCB with 230 VAC and 115 VAC input voltage and full load.

Passed ± 8.8 kV contact discharge at 115 VAC

Contact Discharge Voltage (kV)	Applied to	Number of Strikes	Test Result
+8.8	12 V	10	PASS
-8.8	12 V	10	PASS
+8.8	5 V	10	PASS
-8.8	5 V	10	PASS
+8.8	GND	10	PASS
-8.8	GND	10	PASS

Passed ± 16.5 kV air discharge at 115 VAC

Air Discharge Voltage (kV)	Applied to	Number of Strikes	Test Result
+16.5	12 V	10	PASS
-16.5	12 V	10	PASS
+16.5	5 V	10	PASS
-16.5	5 V	10	PASS
+16.5	GND	10	PASS
-16.5	GND	10	PASS

Passed ± 8.8 kV contact discharge at 230 VAC

Contact Discharge Voltage (kV)	Applied to	Number of Strikes	Test Result
+8.8	12 V	10	PASS
-8.8	12 V	10	PASS
+8.8	5 V	10	PASS
-8.8	5 V	10	PASS
+8.8	GND	10	PASS
-8.8	GND	10	PASS



Passed ± 16.5 kV air discharge at 230 VAC

Air Discharge Voltage (kV)	Applied to	Number of Strikes	Test Result
+16.5	12 V	10	PASS
-16.5	12 V	10	PASS
+16.5	5 V	10	PASS
-16.5	5 V	10	PASS
+16.5	GND	10	PASS
-16.5	GND	10	PASS

Note: In all PASS results, power supply is still functional after the test.

15 Bode Plot

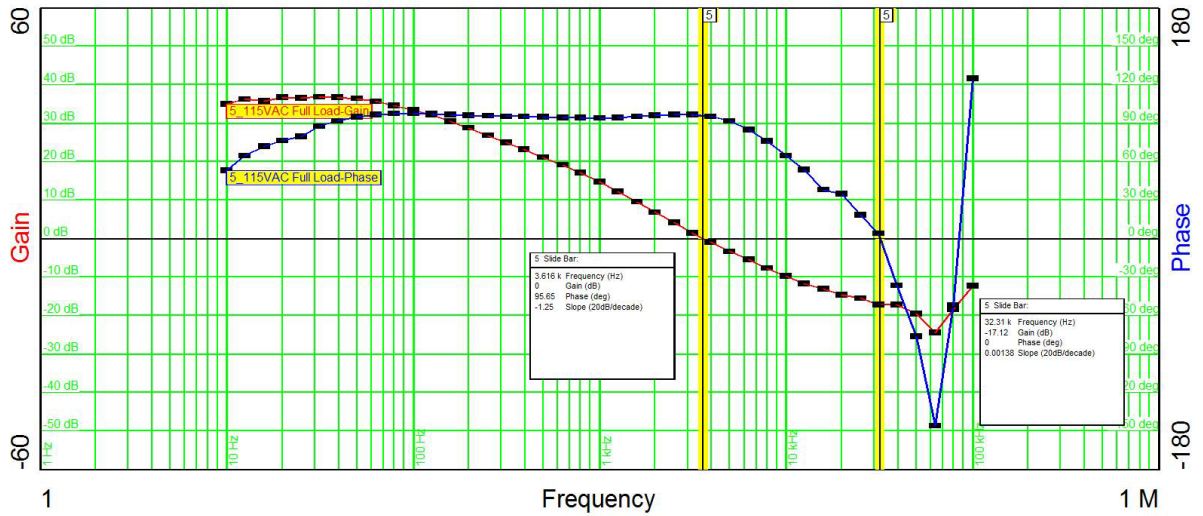

Figure 148 – 115 VAC 60 Hz Full Load.

$F_{cross_over} = 3.62 \text{ kHz}$
 Phase Margin = 95.7°
 Gain Margin = 17.1 dB

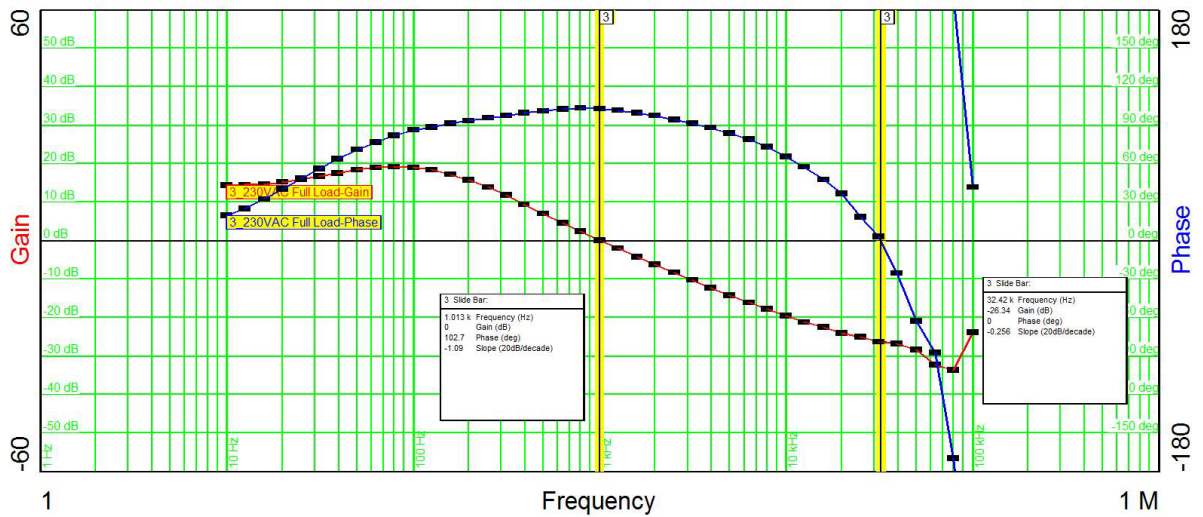

Figure 149 – 230 VAC 50 Hz. Full Load

$F_{cross_over} = 1.01 \text{ kHz}$
 Phase Margin = 103°
 Gain Margin = 26.3 dB



16 Revision History

Date	Author	Revision	Description and Changes	Reviewed
31-Jan-25	RN / RPA	A	Initial Release	Apps & Mktg
12-Dec-25	RN / RPA	B	Removed all ILIM selection as per PCN-25481.	Apps & Mktg
20-May-26	RPA	C	Update figure 1. Section 2: Change 12 V Regulation to 10%. Add alternate parts for C4, C9, C10, C12, C13, and T1. Add Section 15 Bode Plot.	Apps & Mktg



For the latest updates, visit our website: www.power.com

For patent information, Life support policy, trademark information and to access a list of Power Integrations worldwide Sales and engineering support locations and services, please use the links below.



<https://www.power.com/company/sales/sales-offices>

