

SCALE-iFlex™ Single Plug-and-Play Gate Driver

- Fully qualified solution, reduces time-to-market
- Compact footprint, isolated housing
- Advanced active clamping (AAC)
- Comprehensive protection features
- In-line conformal coating

Ready-to-use Gate Driver Solution for 100 x 140 mm IGBT Modules up to 3300 V

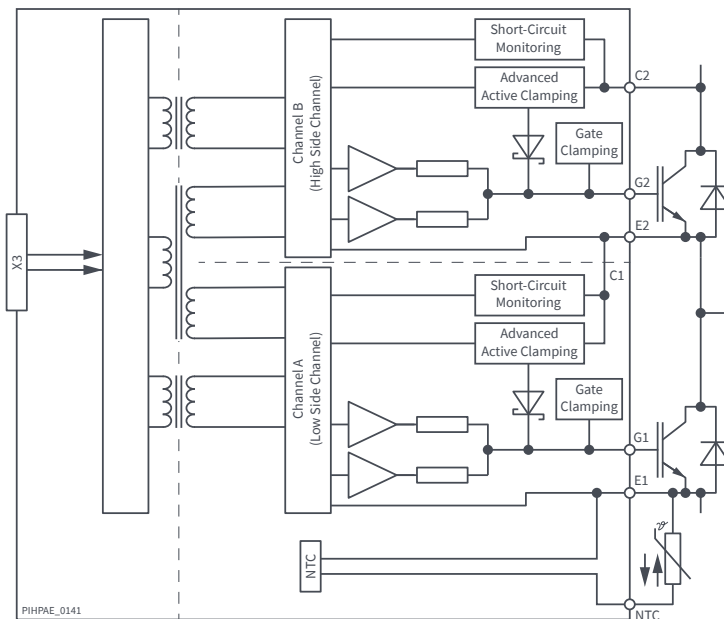

Applications

- Railway main and auxiliary converters
- Wind converters
- Power quality
- Other high-reliability applications

Product Details

Part Number	Power Module	Voltage Class	Current Class	Package	Power Device Supplier
2SIS0400T2C0C-33	N.A.	3300 V	N.N.	XHP™ 2, LV100	N.A.
2SMS0220D2C0C-CM1200DC-34X	CM1200DC-34X	1700 V	1200 A	LV100	Mitsubishi
2SMS0220D2C0C-CM600DA-66X	CM600DA-66X	3300 V	600 A	LV100	Mitsubishi
2SMS0220D2C0C-CM450DA-66X	CM450DA-66X	3300 V	450 A	LV100	Mitsubishi
2SMS0220D2C0C-CM1200DW-24T	CM1200DW-24T	1200 V	1200 A	LV100	Mitsubishi
2SMS0220D2C0C-CM1200DW-40T	CM1200DW-40T	2000 V	1200 A	LV100	Mitsubishi



Design Support

Data Sheet

SCALE-iFlex Single data sheet (www.power.com/scale-iflex-single-data-sheet)