

SCALE™ -2+ Gate Driver Core 2SC0108T

- Switching frequency up to 50 kHz
- 8 A peak output gate current
- 2 x 1 W output power
- +15 V (regulated) / -8 V gate driving
- Interface for 3.3 V – 15 V logic level
- Direct and half-bridge modes
- Supports two-level and multi-level topologies

E321757



Ultra-Compact Dual-Channel Gate Driver Core for up to 1700 V IGBTs

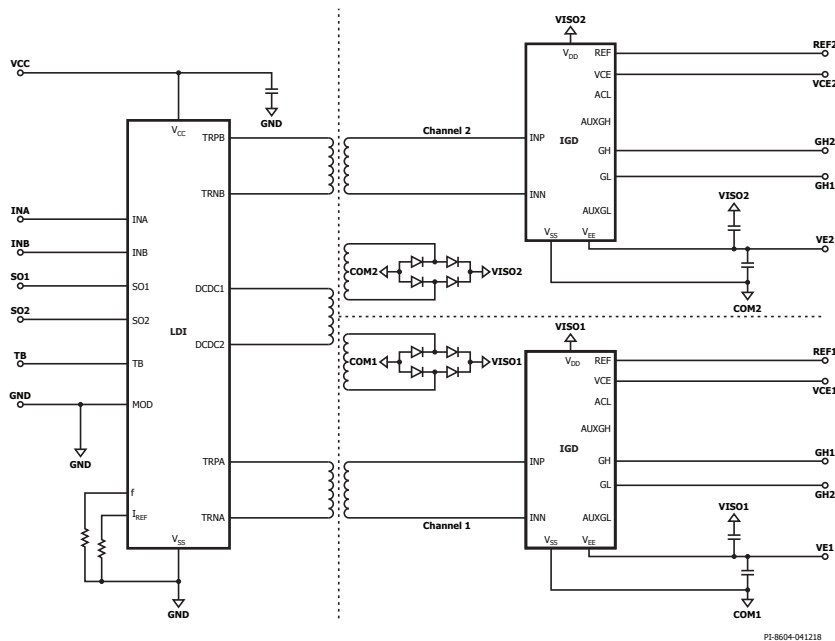

Applications

- General purpose drives (E-bus, E-truck, CAV)
- Uninterruptible power supplies (UPS) • Railway auxiliary inverters • Medical (MRT, CT, X-ray)
- Photovoltaic and wind power inverters • Commercial e-mobility • Medium-voltage drives

Certifications

- Reinforced isolation according to IEC 60664-1
- UL-recognized under E321757 for UL 61800-5-1

Product Details

Parameter	Min	Typical	Max	Unit
Nominal supply voltage		15		V
Supply current @ $f_{in} = 0$ Hz		31		mA
Supply current, full load			260	mA
Output power per channel			1	W
Gate voltage		+15 / -8		V
Peak output current (gate current)	-8		+8	A
Switching frequency (f_s)	0		50	kHz
Duty cycle	0		100	%
Creepage distance primary-secondary	12.9			mm
Clearance distance primary-secondary	12.9			mm
Dielectric test voltage	5000			V_{RMS}
Partial discharge extinction voltage	1768			V_{PEAK}
dv / dt immunity, input-to-output			75	kV/ μ s



Design Support

Available Products 2SC0108 Products list (www.power.com/2SC0108)