

Application Note

# Handling Instructions for SCALE™-1 and SCALE™-2 Gate Drivers

**Scope**

This Application Note defines the requirements for handling the high-power SCALE™-1 and SCALE™-2 products (gate driver cores, plug-and-play gate drivers) and accessories from Power Integrations in terms of:

- Recommended ambient conditions
- Soldering instructions for gate driver core products
- Mechanical handling
- ESD handling

The information given here applies to all customers, distributors and suppliers receiving high-power products from Power Integrations.

**Content**

<b>Scope</b> .....	<b>1</b>
<b>Content</b> .....	<b>1</b>
<b>Recommended Ambient Conditions</b> .....	<b>2</b>
<b>Soldering Instructions for Driver Core Products</b> .....	<b>3</b>
Reflow Soldering.....	3
Wave Soldering .....	3
Selective Soldering.....	3
Manual Soldering .....	4
<b>Mechanical Handling</b> .....	<b>4</b>
Insertion of Gate Driver Cores into the Carrier PCB .....	4
<b>ESD Handling</b> .....	<b>6</b>
IGBT Gate Driver Structure.....	6
<b>Legal Disclaimer</b> .....	<b>7</b>
<b>Manufacturer</b> .....	<b>7</b>
<b>Power Integrations Worldwide High Power Customer Support Locations</b> .....	<b>8</b>

---

 Application Note

**Recommended Ambient Conditions**

Power Integrations products mentioned in this Application Note must be stored according to the environmental conditions specified in Table 1.

<b>Material</b>	<b>Measures</b>	<b>Ambient Atmosphere</b>	<b>Ambient Conditions [Temp. / RH]</b>	<b>Max. Storage Time [Months]</b>
Non-dry pack <sup>1</sup>	Store in original packaging	Dry and dust-free air + free of airborne contaminants	23 °C ± 5 °C <sup>2</sup> RH: 30% to 60%	12

Table 1 : "Environmental conditions and lifetime during storage"

Products must be processed before the end of the maximum storage time. 12 months apply from the day of shipment ex Power Integrations warehouse (In case of exceeding period, customer must perform solderability test)

Processing after the maximum storage time can increase the risk of non-processability or malfunction and is within the responsibility of the customer. Extended warranty products need to be processed within the same maximum storage time to maintain warranty as defined in the terms and conditions of sale.

---

<sup>1</sup> ...Low-pollution atmosphere and packaging

<sup>2</sup> ...Under shipping conditions, recommended ambient temperature range is 0 °C to 60 °C

## Application Note

### Soldering Instructions for Driver Core Products

Power Integrations gate driver cores can be soldered with the following techniques, which are defined for different process conditions.

#### Reflow Soldering

Reflow soldering of drivers is not permitted.

#### Wave Soldering

Parameter	Leaded	Lead-Free
Flux	25 weight % rosin, 75 weight % isopropanol	25 weight % rosin, 75 weight % isopropanol
Solder alloy	Sn63Pb37	Sn96.5Ag3.0Cu0.5
Flux amount	Depending on the PCB size and assembly complexity, the flux is determined to obtain maximum solder on the top side of the PCB with minimal flux residues on the bottom.	
Pot temperature	250 °C	255 °C
Preheating rate	3...4 K/s <sup>3</sup>	
PCB top-side temperature	90...110 °C <sup>4</sup>	
Dipping/dwelling time	3...5 s	
Solder pot contact width	20 mm	
Cooling-down rate	5 K/s <sup>3</sup>	

#### Selective Soldering

Name	Leaded	Lead-Free
Flux	25 weight % rosin, 75 weight % isopropanol	25 weight % rosin, 75 weight % isopropanol
Solder alloy	Sn63Pb37	Sn96.5Ag3.0Cu0.5
Flux amount	The fluxing is determined as per the requirement of the board area and the solder joint size.	
Pot temperature	280...300 °C	
PCB top-side temperature	100...125 °C <sup>4</sup>	
Nozzle dragging rate	2...8 mm/s <sup>5</sup>	
Point soldering time	3...5 s <sup>6</sup>	

<sup>3</sup> ...depending on the length of the wave soldering machine

<sup>4</sup> ...depending on the thermal mass and components on the board when it reaches the solder pot

<sup>5</sup> ...depending on the solder joint size

The solder nozzle should be selected depending on the surface area of the solder joint.

<sup>6</sup> ...depending on the size of the solder joint

## Application Note

### Manual Soldering

Name	Leaded	Lead-Free
Solder iron temperature	320 °C	340 °C (SAC305)
Maximum solder time	3-4 s	

It is recommended to use lead-free solder EF2210, SAC305 alloy. However, other solder types may also be used.

### Mechanical Handling

The correct handling of mechanical gate drivers is based on two fundamental principles:

- 1) No excessive mechanical force must be applied to transformers.
- 2) No excessive mechanical force causing bending (reflected to IPC-T-650) must be applied to PCBs.

The root causes of possible driver failure mentioned above may appear during mounting and later during operation. If the carrier PCB on which the driver core is placed is large, there is a risk of driver PCB bending referring to the carrier PCB. These phenomena can be seen during vibrations tests where momentary displacement between driver core and carrier PCB can be observed. Therefore, if significant vibrations are foreseeable, it is necessary to mechanically stabilize the driver.

### Insertion of Gate Driver Cores into the Carrier PCB

It is recommended that no large steady-state or temporary mechanical force be applied to the transformers or terminals of the gate core drivers. Applying excessive mechanical force to the transformer bends the PCB and considerably stresses the transformer solder joints, leading to potential pre-damage. This increases the probability of cracks at the transformer solder points and other assembled SMD components, especially ceramic capacitors and resistors.

The transformer may be held by hand during removal or insertion from/into the packaging or assembly to carrier PCB, but the PCB should be free from bending.

Fig. 1 illustrates the correct removal and assembly of the driver core. If mechanical force applied to transformer causes PCB bending or excessive mechanical stress to the solder joints, the force must be shifted directly to the corresponding terminals of the driver PCB.

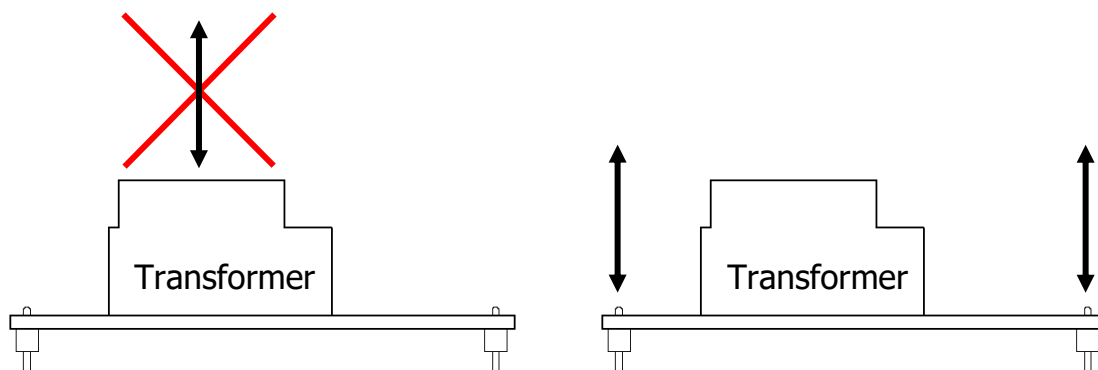

*Fig. 1 Not recommended (left) and recommended (right) ways of handling Power Integrations gate driver cores during assembly (body plan of a driver)*

The IPC-T-650 standard gives general guidance for PCB handling and recommends that PCBs with surface mount components are not exposed to bending or twisting of more than 0.5% in relation to their length and width.



Application Note

**ESD Handling**

The gate driver PCBA's must be processed in an EPA (Electrostatic Protected Area) and a control program for the handling is implemented based on the definitions in IEC 61340-5-1 (or equivalent standard, e.g. ANSI/ESD s20.20).

**IGBT Gate Driver Structure**

Power Integrations gate drivers are based on highly integrated ASIC chipsets of the SCALE™ (SCALE™-1, SCALE™-2) series. These ASIC chipsets are based on bipolar (SCALE-1) and CMOS (SCALE-2) technology respectively. They provide only limited protection against ESD. ESD-appropriate handling is therefore mandatory in order to guarantee correct operation and high reliability.

Fig. 1 shows a schematic of the SCALE-2 gate driver core 2SC0108T, including the direct input and output signals of the chipset.

All driver pins on the high- and low-voltage sides are directly connected to the SCALE-2 chipset. Even though the chipset has integrated ESD protection, the ASIC cannot withstand excessive ESD events and requires sensitive handling regarding electrostatic discharges.

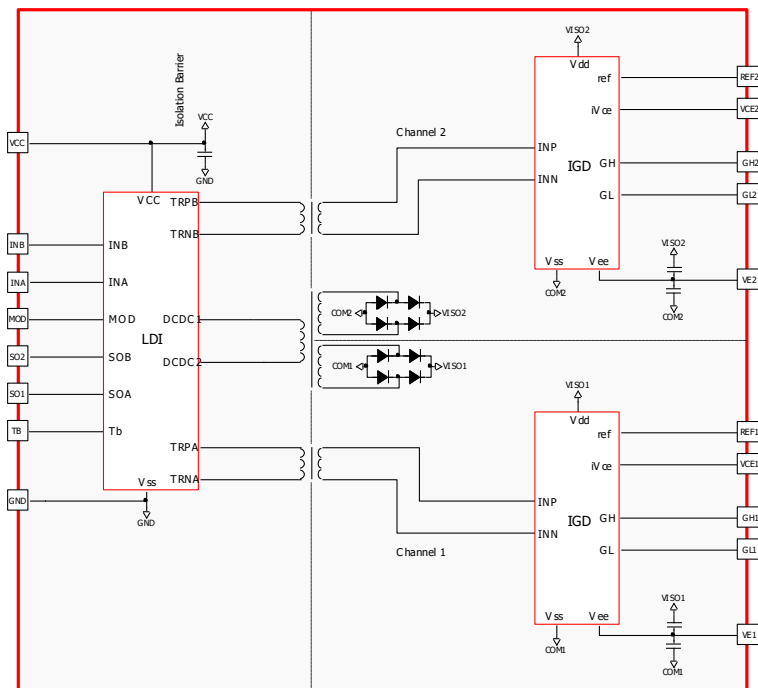

Fig. 4 Schematics of gate driver core 2SC0108T

---

## Application Note

### Legal Disclaimer

The statements, technical information and recommendations contained herein are believed to be accurate as of the date hereof. All parameters, numbers, values and other technical data included in the technical information were calculated and determined to our best knowledge in accordance with the relevant technical norms (if any). They may base on assumptions or operational conditions that do not necessarily apply in general. We exclude any representation or warranty, express or implied, in relation to the accuracy or completeness of the statements, technical information and recommendations contained herein. No responsibility is accepted for the accuracy or sufficiency of any of the statements, technical information, recommendations or opinions communicated and any liability for any direct, indirect or consequential loss or damage suffered by any person arising therefrom is expressly disclaimed.

### Manufacturer

Power Integrations Switzerland  
Längfeldweg 87  
2504 Biel, Switzerland

Phone +41 32 344 47 47  
Fax +41 32 344 47 40  
Email [igbt-driver.support@power.com](mailto:igbt-driver.support@power.com)  
Website [www.power.com/gate-drivers](http://www.power.com/gate-drivers)

© 2026 Power Integrations Switzerland GmbH.

All rights reserved.

We reserve the right to make any technical modifications without prior notice. Version 1.2 from 2026-04-29

## Application Note

**Power Integrations Worldwide High Power Customer Support Locations****WORLD HEADQUARTERS**

5245 Hellyer Avenue  
San Jose, CA 95138 USA  
Tel: +1-408-414-9200  
Fax: +1-408-414-9765  
Email: [usasales@power.com](mailto:usasales@power.com)

**AMERICAS WEST**

5245 Hellyer Avenue  
San Jose, CA 95138 USA  
Tel: +1-408-414-8778  
Fax: +1-408-414-3760  
Email: [usasales@power.com](mailto:usasales@power.com)

**GERMANY** (AC-DC/LED Sales)

Einsteinring 24  
85609 Aschheim, Germany  
Tel: +49-89-5527-39100  
Fax: +49-89-1228-5374  
Email: [eurossales@power.com](mailto:eurossales@power.com)

**INDIA** (Mumbai)

Unit: 106-107, Sagar Tech Plaza-B  
Sakinaka, Andheri Kurla Road  
Mumbai, Maharashtra 400072 India  
Tel 1: +91-22-4003-3700  
Tel 2: +91-22-4003-3600  
Email: [indiasales@power.com](mailto:indiasales@power.com)

**JAPAN**

Kosei Dai-3 Bldg.  
2-12-11, Shin-Yokohama, Kohoku-ku  
Yokohama-shi, Kanagawa  
Japan 222-0033  
Tel: +81-45-471-1021  
Fax: +81-45-471-3717  
Email: [japansales@power.com](mailto:japansales@power.com)

**TAIWAN**

5F, No. 318, Nei Hu Rd., Sec. 1  
Nei Hu Dist.  
Taipei, 114 Taiwan  
Tel: +886-2-2659-4570  
Fax: +886-2-2659-4550  
Email: [taiwansales@power.com](mailto:taiwansales@power.com)

**AMERICAS EAST**

7360 McGinnis Ferry Road  
Suite 225  
Suwannee, GA 30024 USA  
Tel: +1-678-957-0724  
Fax: +1-678-957-0784  
Email: [usasales@power.com](mailto:usasales@power.com)

**CHINA** (Shanghai)

Room 2410, Charity Plaza  
No. 88 North Caoxi Road  
Shanghai, 200030 China  
Tel: +86-21-6354-6323  
Fax: +86-21-6354-6325  
Email: [chinasales@power.com](mailto:chinasales@power.com)

**GERMANY** (Gate Driver Sales)

HellwegForum 3  
59469 Ense, Germany  
Tel: +49-2938-64-39990  
Email: [gate-drivers.sales@power.com](mailto:gate-drivers.sales@power.com)

**INDIA** (New Delhi)

#45, Top Floor  
Okhla Industrial Area, Phase - III  
New Delhi, 110020 India  
Tel 1: +91-11-4055-2351  
Tel 2: +91-11-4055-2353  
Email: [indiasales@power.com](mailto:indiasales@power.com)

**KOREA**

RM602, 6FL, 22  
Teheran-ro 87-gil, Gangnam-gu  
Seoul, 06164 Korea  
Tel: +82-2-2016-6610  
Fax: +82-2-2016-6630  
Email: [koreasales@power.com](mailto:koreasales@power.com)

**UNITED KINGDOM**

Building 5, Suite 21  
The Westbrook Centre  
Milton Road  
Cambridge, CB4 1YG United Kingdom  
Tel: +44-7823-557-484  
Email: [eurossales@power.com](mailto:eurossales@power.com)

**AMERICAS CENTRAL**

333 Sheridan Road  
Winnetka, IL 60093 USA  
Tel: +1-847-721-6293  
Email: [usasales@power.com](mailto:usasales@power.com)

**CHINA** (Shenzhen)

17/F, Hivac Building, No 2  
Keji South 8th Road, Nanshan District  
Shenzhen, 518057 China  
Tel: +86-755-8672-8689  
Fax: +86-755-8672-8690  
Email: [chinasales@power.com](mailto:chinasales@power.com)

**INDIA** (Bangalore)

#1, 14th Main Road  
Vasanthangar  
Bangalore, 560052 India  
Tel 1: +91-80-4113-8020  
Tel 2: +91-80-4113-8028  
Fax: +91-80-4113-8023  
Email: [indiasales@power.com](mailto:indiasales@power.com)

**ITALY**

Via Milanese 20  
20099 Sesto San Giovanni (MI), Italy  
Tel: +39-02-4550-8708  
Email: [eurossales@power.com](mailto:eurossales@power.com)

**SINGAPORE**

51 Newton Road  
#19-01/05 Goldhill Plaza  
Singapore, 308900  
Tel 1: +65-6358-2160  
Tel 2: +65-6358-4480  
Fax: +65-6358-2015  
Email: [singaporesales@power.com](mailto:singaporesales@power.com)