



---

## Design Example Report

<b>Title</b>	<b><i>175 mW Constant Voltage, Universal Input, Non-Isolated Buck Converter Using LinkSwitch™-TN2 LNK3202D</i></b>
<b>Specification</b>	85 VAC – 265 VAC Input; 5.0 V, 35 mA Output
<b>Application</b>	Small Appliance
<b>Author</b>	Applications Engineering Department
<b>Document Number</b>	DER-507
<b>Date</b>	November 8, 2016
<b>Revision</b>	1.0

### **Summary and Features**

- Lowest cost and component count Buck-converter solution
- Excellent output voltage load regulation (<5% 5 V<sub>TYP</sub>)
- Excellent output voltage line regulation (<2% 5 V<sub>TYP</sub>)
- Programmable current limit enables selection of inductor with low current rating
- Reduced dissipation during output short circuit fault
- Low no-load input power, <120 mW
- Low output voltage ripple <100 mV<sub>PK-PK</sub>
- > 5 dB conducted EMI margin

### **PATENT INFORMATION**

The products and applications illustrated herein (including transformer construction and circuits external to the products) may be covered by one or more U.S. and foreign patents, or potentially by pending U.S. and foreign patent applications assigned to Power Integrations. A complete list of Power Integrations' patents may be found at [www.powerint.com](http://www.powerint.com). Power Integrations grants its customers a license under certain patent rights as set forth at <<http://www.powerint.com/ip.htm>>.

---

### **Power Integrations**

5245 Hellyer Avenue, San Jose, CA 95138 USA.  
Tel: +1 408 414 9200 Fax: +1 408 414 9201  
[www.power.com](http://www.power.com)

## Table of Contents

1	Introduction .....	4
2	Power Supply Specification .....	6
3	Schematic.....	7
4	Circuit Description .....	8
4.1	Input Stage.....	8
4.2	EMI Filters.....	8
4.3	LinkSwitch-TN2 Circuit Operation.....	8
5	PCB Layout .....	9
6	Bill of Materials .....	10
7	Transformer Design Spreadsheet .....	11
8	Performance Data .....	13
8.1	Full Load Efficiency vs. Input Line Voltage.....	13
8.2	Efficiency vs. Load .....	14
8.3	No-Load Input Power .....	15
8.4	Line and Load Regulation .....	16
8.4.1	Line Regulation.....	16
8.4.2	Load Regulation.....	17
9	Waveforms .....	18
9.1	Output Voltage Ripple.....	18
9.1.1	Measurement Results .....	19
9.2	Output Voltage Start-up .....	21
9.3	Output Load Transient (Dynamic Load).....	21
9.3.1	0% - 100% Load .....	21
9.3.2	50% - 100% Load.....	22
9.4	Drain Waveforms.....	23
9.4.1	Normal Operation $V_{DS}$ and $I_{DS}$ .....	23
9.4.2	Start-up Operation $V_{DS}$ and $I_{DS}$ .....	24
9.5	Free Wheel Diode Waveforms.....	24
9.5.1	Normal Operation 100% Load.....	24
9.6	Output Short Waveforms.....	25
9.6.1	Output Short-Circuit Protection .....	25
9.7	Thermal Performance at Room Temperature .....	26
9.7.1	Thermal Performance at 85 VAC .....	26
9.7.2	Thermal Performance at 265 VAC .....	27
10	Conducted EMI .....	28
10.1	Test Set-up Equipment .....	28
10.1.1	Equipment and Load Used .....	28
10.2	Test Set-up .....	28
10.3	Floating Output (QP / AV) .....	29
10.3.1	115 VAC.....	29
10.3.2	230 VAC.....	31



11 Line Surge.....33  
12 Revision History .....34

**Important Note:**

Although this board is designed to satisfy safety isolation requirements, the engineering prototype has not been agency approved. Therefore, all testing should be performed using an isolation transformer to provide the AC input to the prototype board.



## 1 Introduction

This engineering report describes a buck converter power supply designed to provide a nominal output voltage of 5 V at 35 mA load from a wide input voltage range of 85 VAC to 265 VAC. It utilizes the LNK3202D from the LinkSwitch™-TN2 family of devices.

The LinkSwitch-TN2 ICs are specifically designed to replace all linear and capacitor-fed (cap dropper) non-isolated power supplies in the under 360 mA output current range at equal system cost while offering much higher performance and energy efficiency.

The DER-507 provides a single 5 V buck output. The key design goal is a low cost solution intended for adapter applications.

The document contains the power supply specification, schematic, bill of materials, transformer documentation, printed circuit layout, performance and test data.





Figure 1 – Populated Circuit Board, Top View.

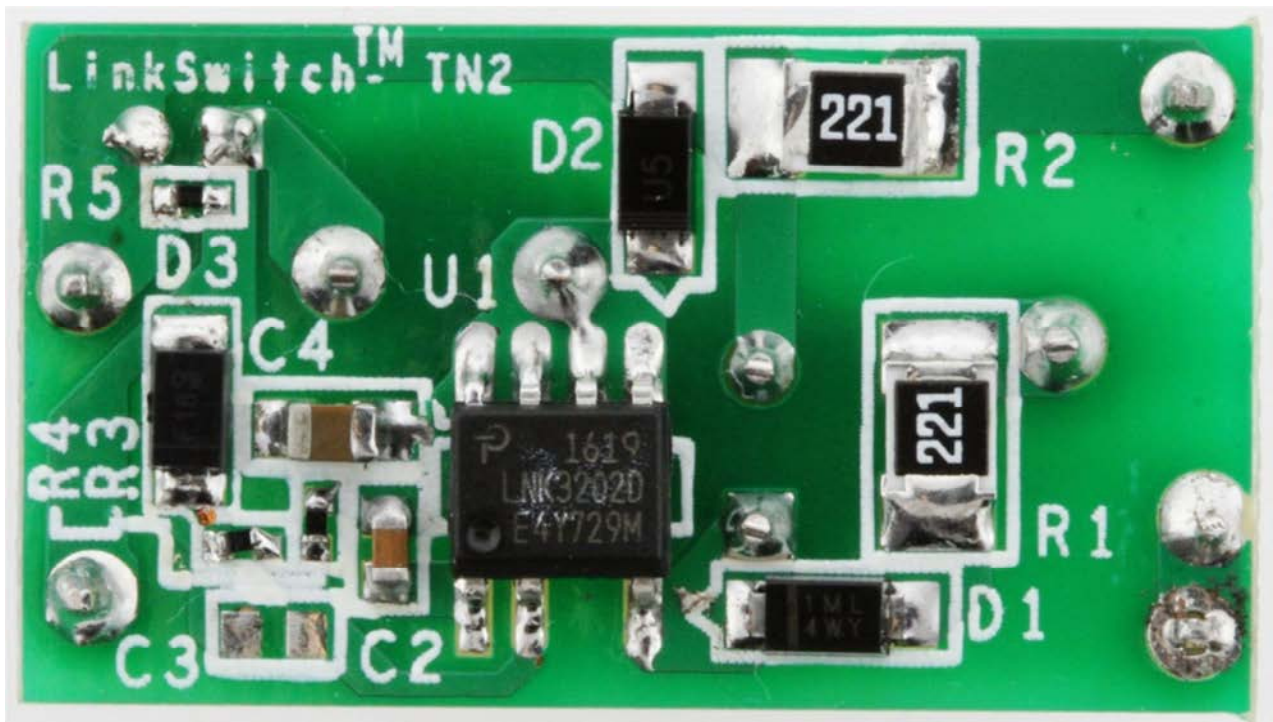


Figure 2 – Populated Circuit Board, Bottom View.

## 2 Power Supply Specification

The table below represents the minimum acceptable performance of the design. Actual performance is listed in the results section.

Description	Symbol	Min	Typ	Max	Units	Comment
<b>Input</b>						
Voltage	$V_{IN}$	85		265	VAC	2 Wire – no P.E.
Frequency	$f_{LINE}$	47	50/60	63	Hz	
No-load Input Power				120	mW	
<b>Output</b>						
Output Voltage	$V_{OUT}$	4.75	5	5.25	V	Output Ripple Voltage Measured at the Board Output Terminals.
Output Current	$I_{OUT}$		35		mA	
Output Ripple Voltage	$V_{RIPPLE}$			100	mV	
Rated Output Power	$P_{OUT}$		175		mW	
<b>Efficiency</b>						
Full Load	$\eta$	45%				With rated full load
<b>Environmental</b>						
Conducted EMI			CISPR22B / EN55022B Load Floating			>5 dB Margin Using Resistive Load.
Line Surge Differential mode (L1/N)				1	kV	Differential: 2 $\Omega$ .
<b>Ambient Temperature</b>	$T_{AMB}$	0		40	$^{\circ}C$	Free Convection, Sea Level

### 3 Schematic

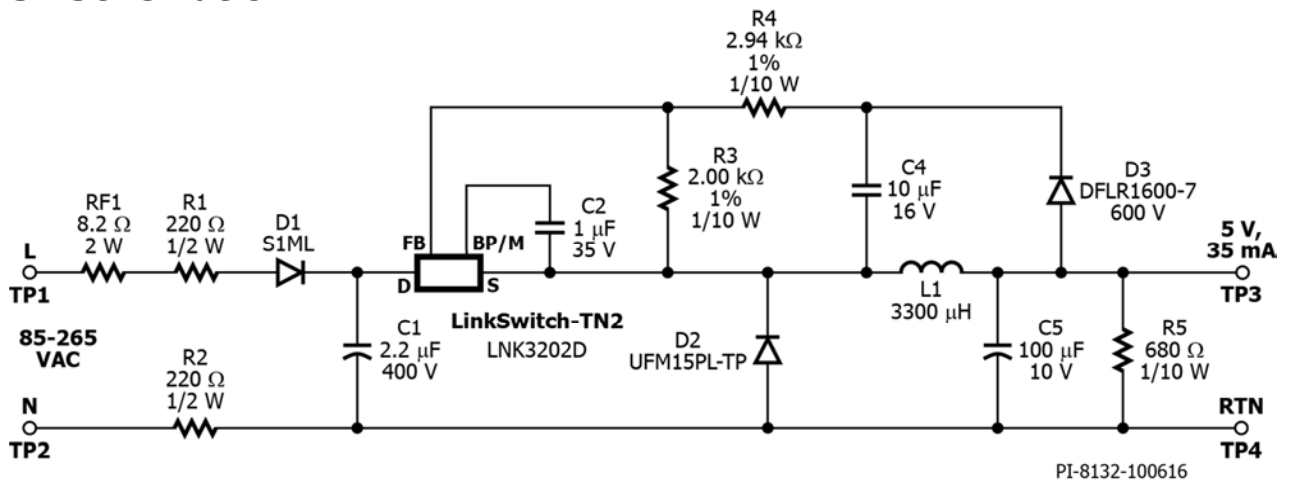


Figure 3 – Schematic.



## 4 Circuit Description

### 4.1 *Input Stage*

Fusible resistor RF1 provides protection against component short circuit failure drawing large current from the input. Half-wave rectified input to LinkSwitch-TN2 IC is provided by D1.

### 4.2 *EMI Filters*

The resistors R1, R2 together with the input filter capacitor C1, work as an EMI filter. These EMI filters ensure compliance with the EN55022 Class B emission limit.

### 4.3 *LinkSwitch-TN2 Circuit Operation*

The controller IC, U1, is configured as a high-side buck switch regulator. IC U1, inductor L1, capacitor C5 and diode D2 form the buck converter.

During normal operation, the IC is powered by the DRAIN (D) pin and charges the BP-pin capacitor C2. This BP-pin capacitor sets the programmable current limit. IC U1 uses ON-OFF control to regulate the output voltage. When the MOSFET inside IC U1 turns OFF, freewheeling diode D2 conducts. When the diode D2 conducts, voltage across inductor L1 is the sum of output voltage and the diode drop of D2. This voltage is impressed at the input of the rectifier and filter stage comprising of diode D3 and capacitor C4. With the voltage drops of diodes D2 and D3 approximately the same, the voltage across capacitor C4 tracks the voltage across output capacitor C5.

Output voltage is sampled by the FEEDBACK (FB) pin through the feedback resistors R3 and R4 by sampling the voltage across capacitor C4 which is the direct representation of the output voltage.

Resistor R5 acts as a pre-load to control the output voltage during no-load condition. Increasing the value of this resistor can help to reduce the no-load power consumption however it also leads to higher voltage regulation at no-load.



### 5 PCB Layout

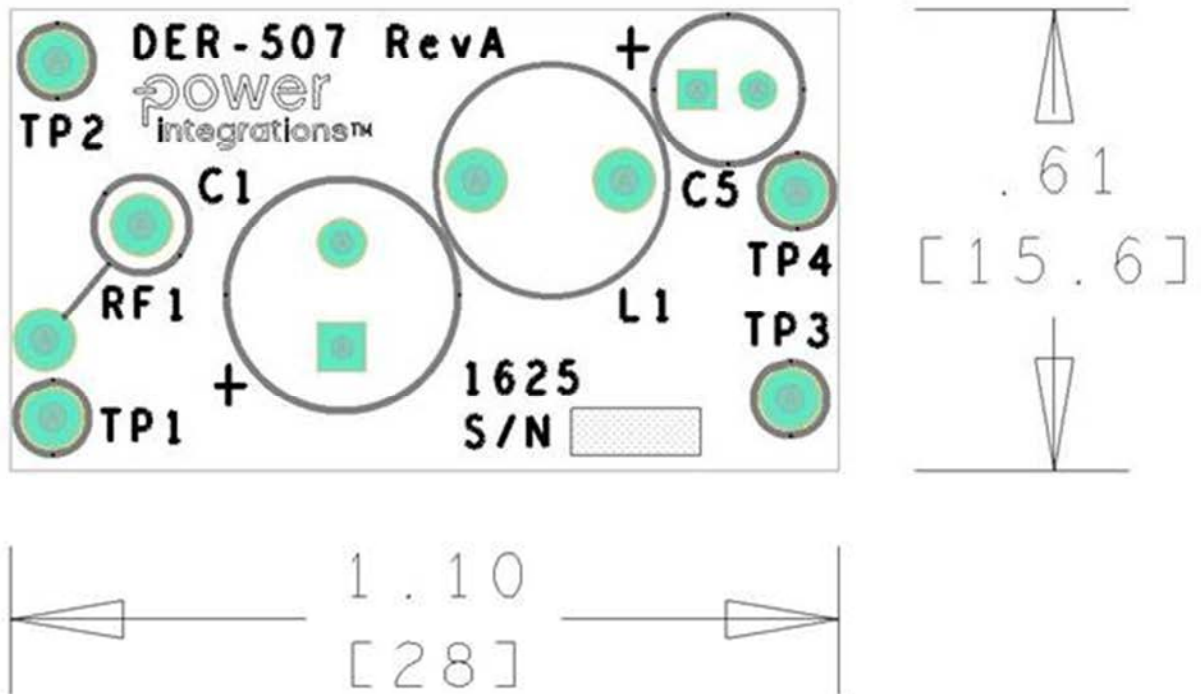


Figure 4 – Top Side.

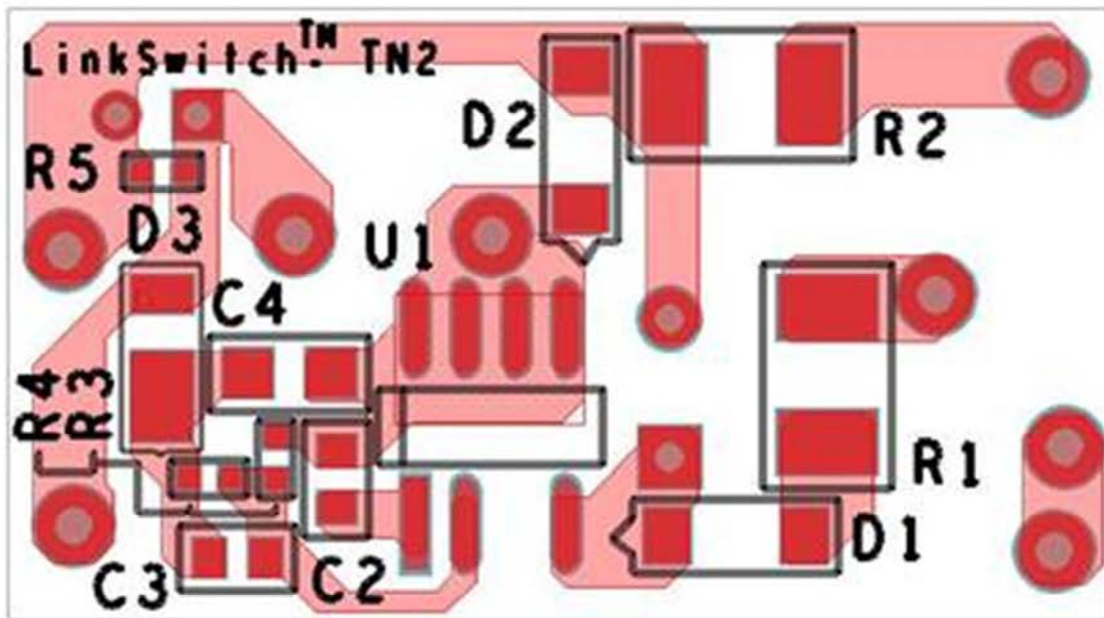


Figure 5 – Bottom Side.

## 6 Bill of Materials

Item	Qty	Ref Des	Description	Mfg Part Number	Manufacturer
1	1	C1	2.2 $\mu$ F, 400 V, Electrolytic, (8 x 11.5)	EKMG401ELL2R2MHB5D	United Chemi-con
2	1	C2	1 $\mu$ f 35 V, Ceramic, X7R, 0603	C1608X7R1V105M	TDK
3	1	C4	10 $\mu$ F, $\pm$ 10%, 16 V, X7R, Ceramic Capacitor, -55 $^{\circ}$ C ~ 125 $^{\circ}$ C, SMT, MLCC 0805 (2012 Metric), 0.079" L x 0.049" W (2.00 mm x 1.25 mm)	CL21B106KOQNNNG	Samsung
4	1	C5	100 $\mu$ F, 10 V, Electrolytic, Low ESR, 500 m $\Omega$ , (5 x 11.5)	ELXZ100ELL101MEB5D	Nippon Chemi-Con
5	1	D1	1 kV, 1 A, Standard Recovery, SMA	S1ML	TAIWAN SEMI
6	1	D2	600 V, 1 A, Ultrafast Recovery, 75 ns, SOD-123	UFM15PL-TP	Micro Commercial
7	1	D3	600 V, 1 A, Rectifier, Glass Passivated, POWERDI123	DFLR1600-7	Diodes, Inc.
8	1	L1	Inductor 3300 $\mu$ H .28 A 8095 RAD	744772332	Würth
9	1	R1	RES, 220 $\Omega$ , 5%, 1/2 W, Thick Film, 1210	ERJ-14YJ221U	Panasonic
10	1	R2	RES, 220 $\Omega$ , 5%, 1/2 W, Thick Film, 1210	ERJ-14YJ221U	Panasonic
11	1	R3	RES, 2.00 k $\Omega$ , 1%, 1/10 W, Thick Film, 0402	ERJ-2RKF2001X	Panasonic
12	1	R4	RES, 2.94 k $\Omega$ , 1%, 1/10 W, Thick Film, 0402	ERJ-2RKF2941X	Panasonic
13	1	R5	RES, 680 $\Omega$ , 5%, 1/10 W, Thick Film, 0402	ERJ-2GEJ681X	Panasonic
14	1	RF1	RES, 8.2 $\Omega$ , 2 W, Fusible/Flame Proof Wire Wound	CRF253-4 5T 8R2	Vitrohm
15	1	TP1	Test Point, WHT, Miniature THRU-HOLE MOUNT	5002	Keystone
16	2	TP2 TP4	Test Point, BLK, Miniature THRU-HOLE MOUNT	5001	Keystone
17	1	TP3	Test Point, RED, Miniature THRU-HOLE MOUNT	5000	Keystone
18	1	U1	LinkSwitch-TN2, SO-8C	LNK3202D	Power Integrations



## 7 Transformer Design Spreadsheet

ACDC_LinkSwitchTN2-Buck_071816; Rev.0.1; Copyright Power Integrations 2016	INPUT	INFO	OUTPUT	UNIT	ACDC_LinkSwitchTN2 Buck
<b>ENTER APPLICATION VARIABLES</b>					
LINE VOLTAGE RANGE			Universal		AC line voltage range
VACMIN			85.00	volts AC	Minimum AC line voltage
VACTYP			115.00	volts AC	Typical AC line voltage
VACMAX			265.00	volts AC	Maximum AC line voltage
fL			50.00	Hz	AC mains frequency
LINE RECTIFICATION TYPE	H		H		Select 'F'ull wave rectification or 'H'alf wave rectification
VOUT	5.00		5.00	volts DC	Output voltage
IOUT	0.035		0.035	A	Average output current
EFFICIENCY	0.47		0.47		Efficiency estimate at output terminals
POUT			0.18	W	Continuous Output Power
CIN	2.20		2.20	uF	Input capacitor
VMIN			93.2	volts DC	Valley of the rectified input voltage
<b>ENTER LINKSWITCH-TN2 VARIABLES</b>					
OPERATION MODE			MDCM		Mostly discontinuous mode of operation
CURRENT LIMIT MODE	RED		RED		Choose 'RED' for reduced current limit or 'STD' for standard current limit
PACKAGE	SO-8C		SO-8C		Select the device package
DEVICE SERIES	LNK32X2		LNK32X2		Generic LinkSwitch-TN2 device
DEVICE CODE			LNK3202		Required LinkSwitch-TN2 device
ILIMITMIN			0.070	A	Minimum current limit of the device
ILIMITTYP			0.080	A	Typical current limit of the device
ILIMITMAX			0.090	A	Maximum current limit of the device
RDSON			88.40	ohms	MOSFET's on-time drain to source resistance at 100degC
FSMIN			62000	Hz	Minimum switching frequency
FSTYP			68000	Hz	Typical switching frequency
FSMAX			72000	Hz	Maximum switching frequency
VDSON			2.00	volts DC	MOSFET on-time drain to source voltage estimate
DUTY			0.15		Maximum duty cycle
TIME_ON			2.411	us	MOSFET conduction time at the minimum line voltage
TIME_ON_MIN			0.714	us	MOSFET conduction time at the maximum line voltage
IRMS_MOSFET			0.016	A	MOSFET RMS current
<b>BUCK INDUCTOR PARAMETERS</b>					
INDUCTANCE_MIN			2970	uH	Minimum design inductance required for power delivery
INDUCTANCE_TYP	3300		3300	uH	Typical design inductance required for power delivery
INDUCTANCE_MAX			3630	uH	Maximum design inductance required for power delivery
TOLERANCE_INDUCTANCE			10	%	Tolerance of the design inductance
FACTOR_LOSS			0.85		Factor that accounts for "off-state" power loss to be supplied by inductor
IRMS_INDUCTOR			0.063	A	Inductor RMS current
<b>FREEWHEELING DIODE PARAMETERS</b>					
VF_FREEWHEELING			0.70	volts DC	Forward voltage drop of the freewheeling

					diode
PIV			600	volts DC	Peak inverse voltage rating of the freewheeling diode
IRMS_DIODE			0.061	A	Diode RMS current
TRR			<75	ns	Required reverse recovery time of the selected diode
<b>BIAS/FEEDBACK PARAMETERS</b>					
VF_BIAS			0.70	volts DC	Forward voltage drop of the bias diode
RBIAS			2490	Ohms	Bias resistor
RBP			1.0	uF	BP pin capacitor
RFB			3480	Ohms	Feedback resistor
CFB			10	uF	Feedback capacitor
C_SOFTSTART				uF	No soft-start capacitor required



## 8 Performance Data

### 8.1 Full Load Efficiency vs. Input Line Voltage

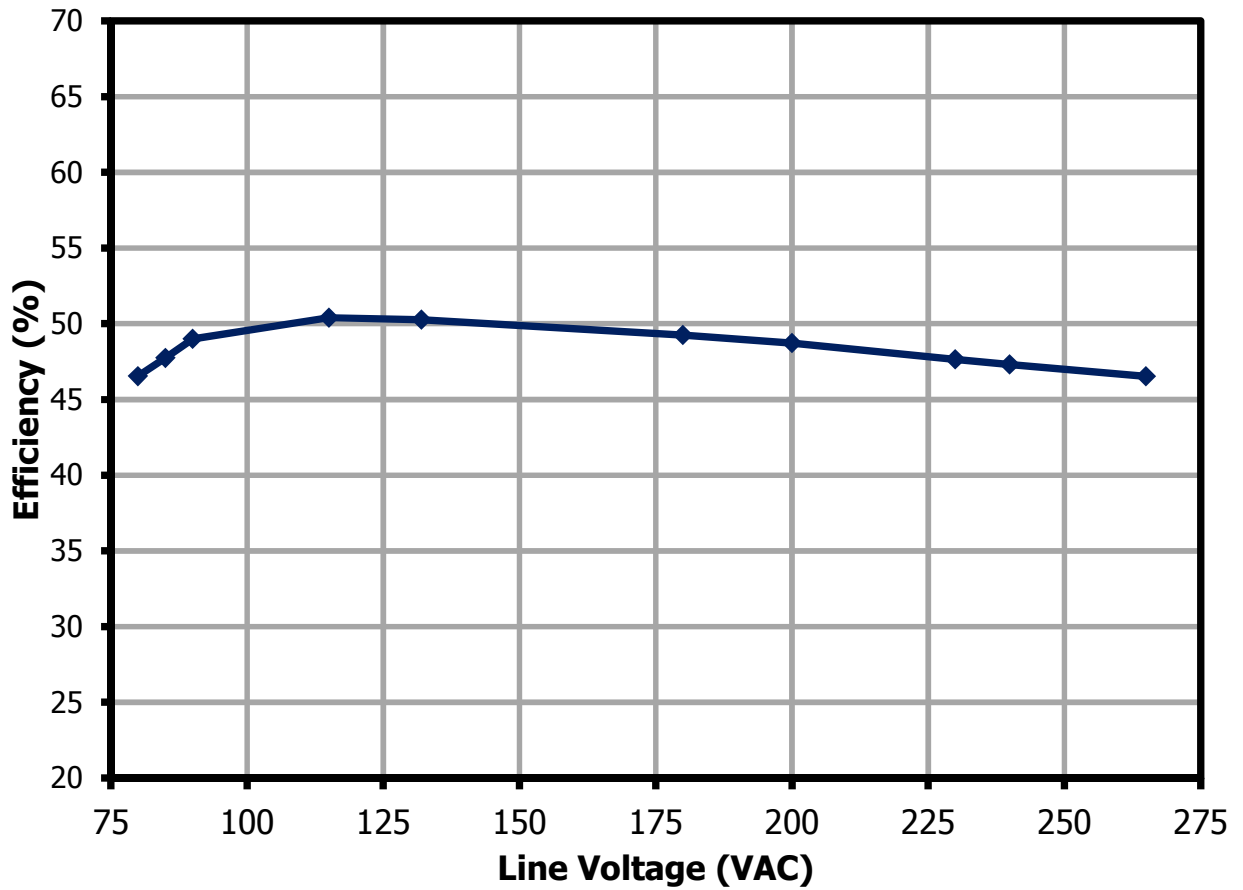


Figure 6 – Efficiency vs. Line Voltage, Room Temperature.



### 8.2 Efficiency vs. Load

Efficiency at 5 V Output (5%-100% on 5 V)

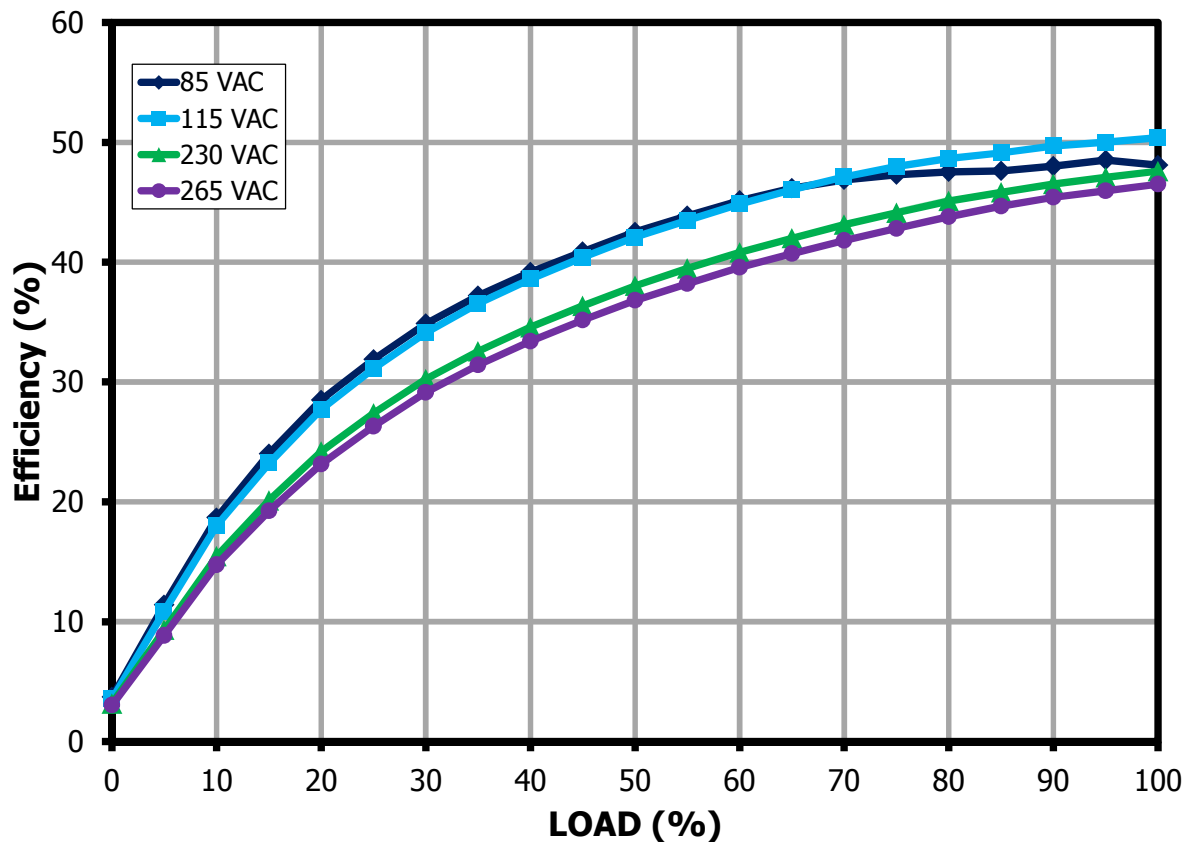
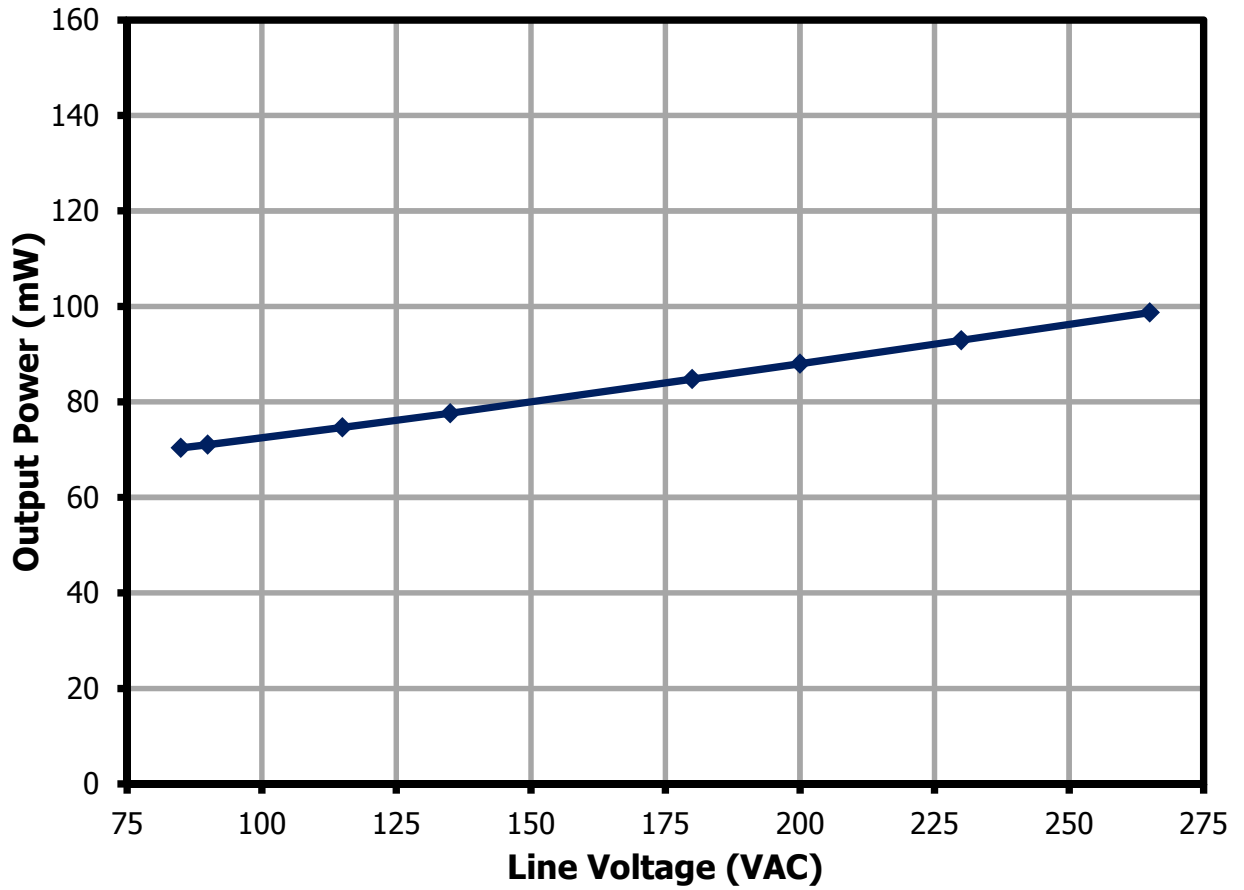


Figure 7 – Efficiency vs. Load, Room Temperature (Measured at the Output Terminal).

8.3 **No-Load Input Power**



**Figure 8** – Input Power vs. Input Line Voltage at No-Load, Room Temperature.



### 8.4 Line and Load Regulation

#### 8.4.1 Line Regulation

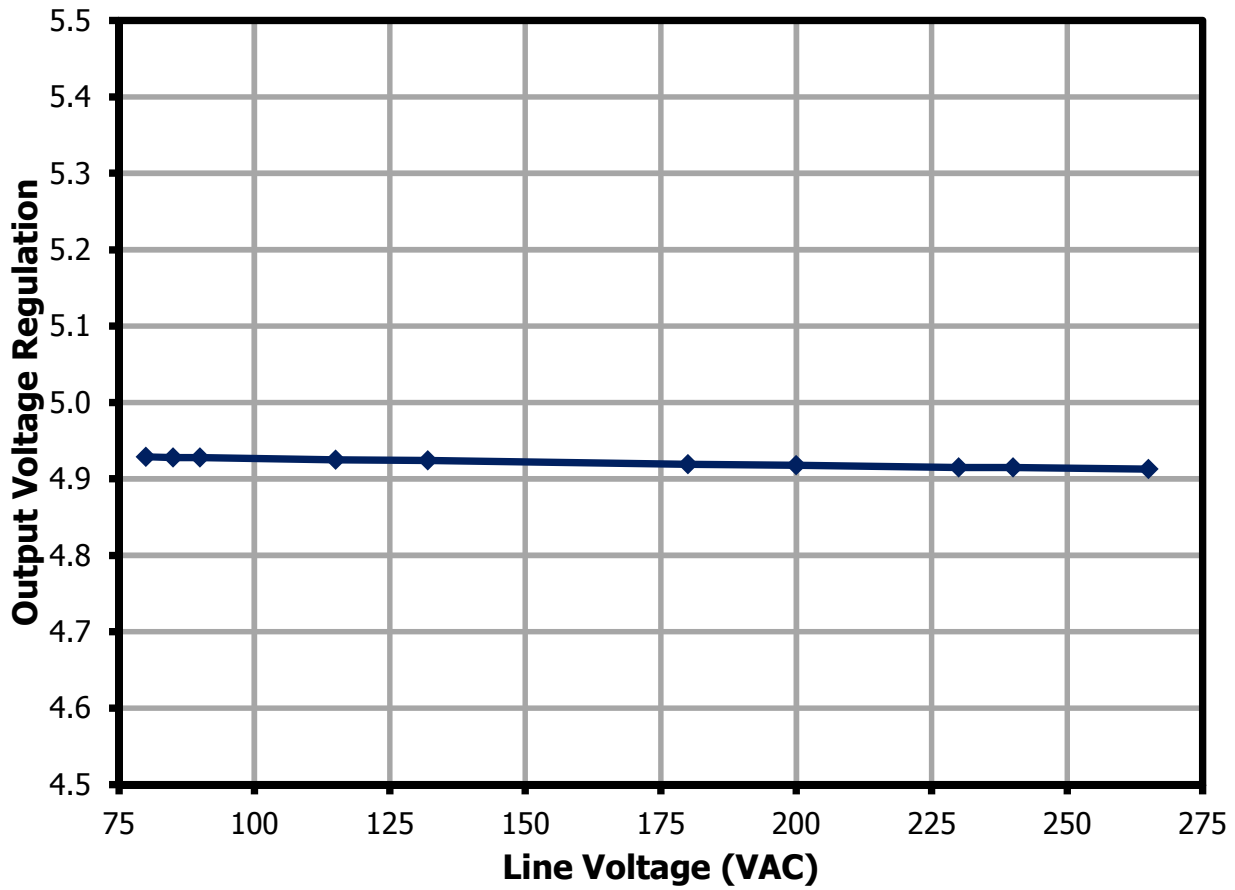


Figure 9 – Measured at the Board Output Terminals at Room Temperature.



8.4.2 Load Regulation

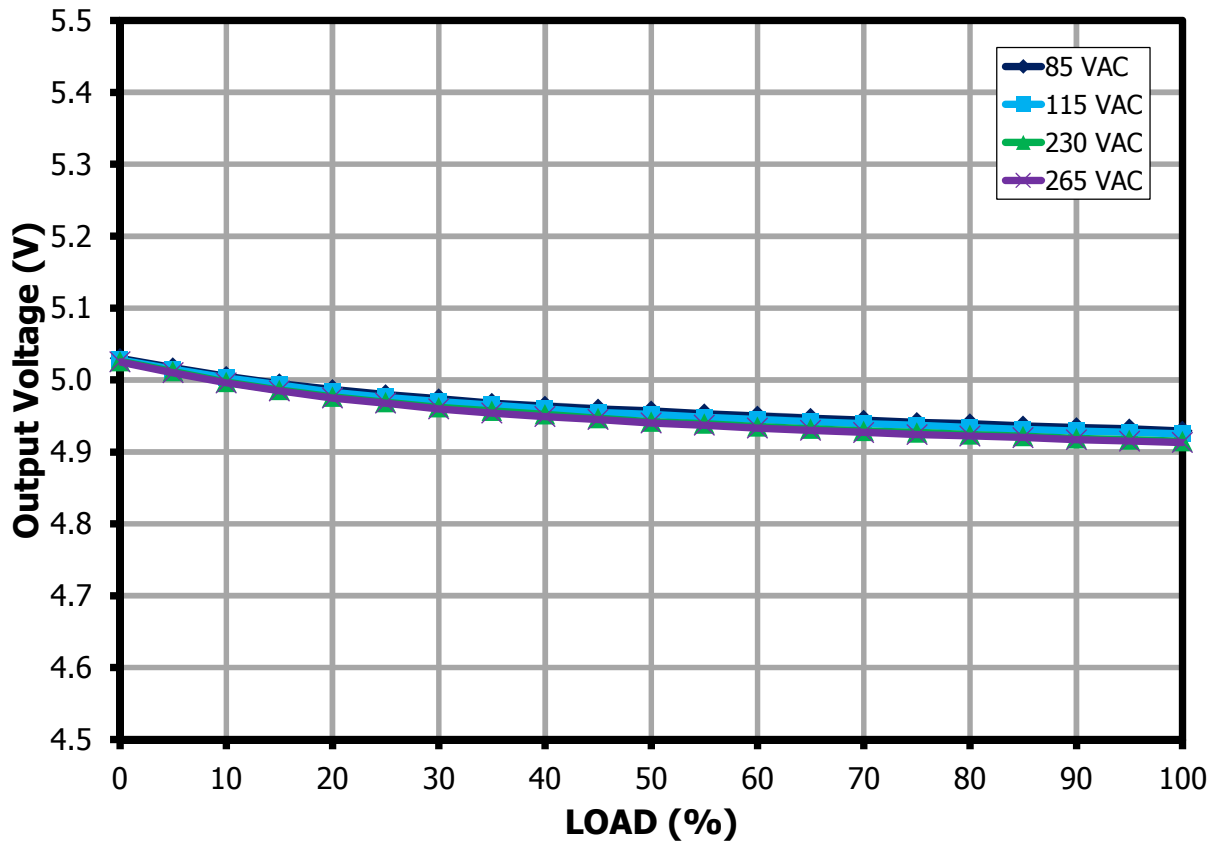


Figure 10 – Measured at the Board Output Terminals at Room Temperature.

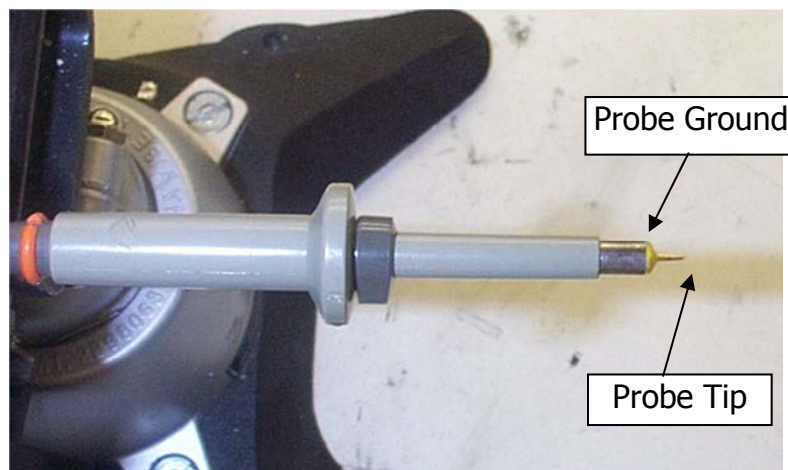


## 9 Waveforms

### 9.1 Output Voltage Ripple

For DC output ripple measurements, a modified oscilloscope test probe must be utilized in order to reduce spurious signals due to pick-up. Details of the probe modification are provided in the Figures below.

The 4987BA probe adapter is affixed with two capacitors tied in parallel across the probe tip. The capacitors include one (1) 0.1  $\mu\text{F}/50\text{ V}$  ceramic type and one (1) 1  $\mu\text{F}/50\text{ V}$  aluminum electrolytic. The aluminum electrolytic type capacitor is polarized, so proper polarity across DC outputs must be maintained (see below).



**Figure 11** – Oscilloscope Probe Prepared for Ripple Measurement. (End Cap and Ground Lead Removed)



**Figure 12** – Oscilloscope Probe with Probe Master ([www.probemaster.com](http://www.probemaster.com)) 4987A BNC Adapter. (Modified with wires for ripple measurement, and two parallel decoupling capacitors added)

9.1.1 Measurement Results

9.1.1.1 Output Ripple Graph from 0-100%

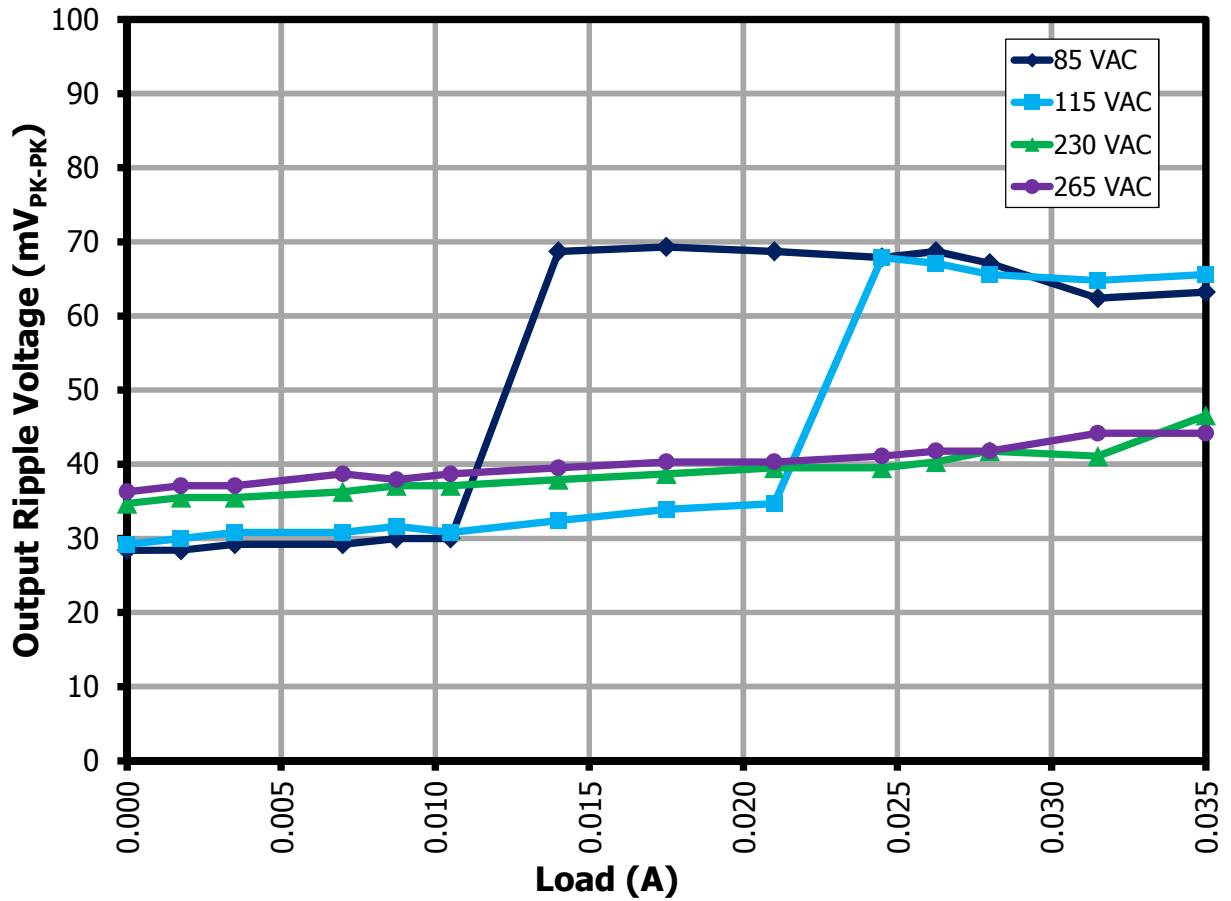
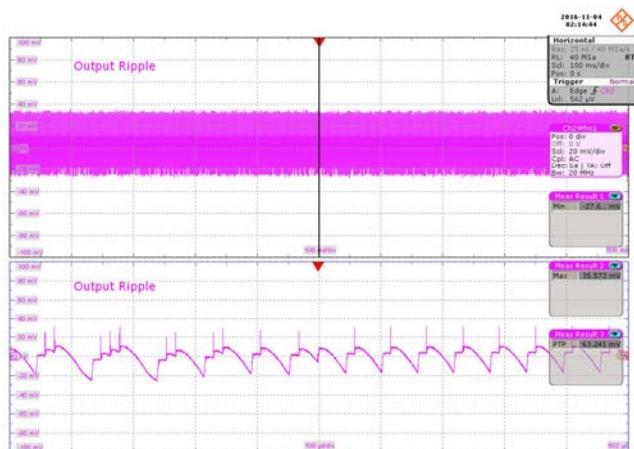


Figure 13 – Measured at the Board Output Terminals at Room Temperature.

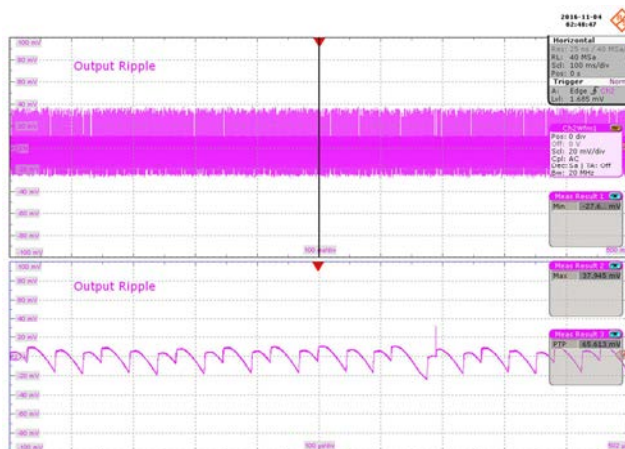
85 V RIPPLE (mV <sub>PK-PK</sub> )	115 V RIPPLE (mV <sub>PK-PK</sub> )	230 V RIPPLE (mV <sub>PK-PK</sub> )	265 V RIPPLE (mV <sub>PK-PK</sub> )
63.241	65.613	46.64	44.269



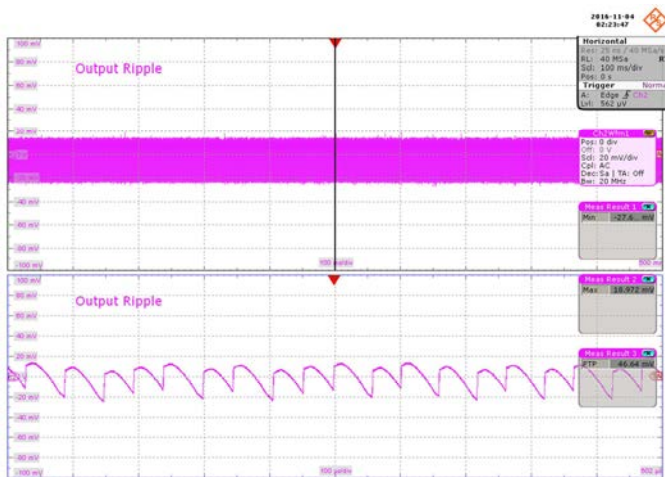
9.1.1.2 Output Ripple Voltage Waveforms for 5 V Output



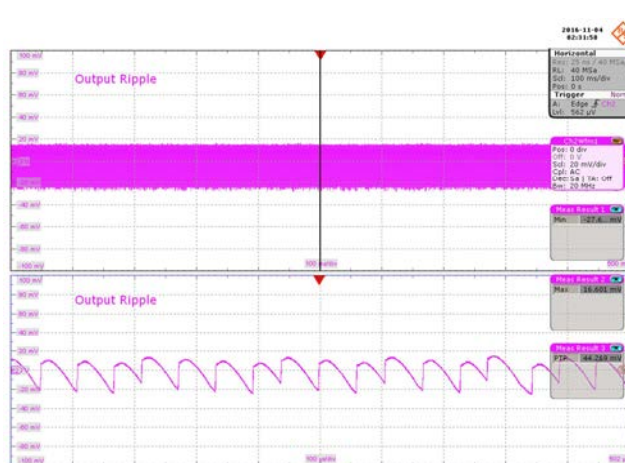
**Figure 14** – 85 VAC Input.  
 Condition: 5 V – 35 mA.  
 $V_{RIPPLE}$ , 20 mV / div., 100 ms / div.  
 Zoom, 100  $\mu$ s / div.  
 $V_{RIPPLE(PK-PK)}$ : 63.241 mV.



**Figure 15** – 115 VAC Input.  
 Condition: 5 V – 35 mA.  
 $V_{RIPPLE}$ , 20 mV / div., 100 ms / div.  
 Zoom, 100  $\mu$ s / div.  
 $V_{RIPPLE(PK-PK)}$ : 65.613 mV.



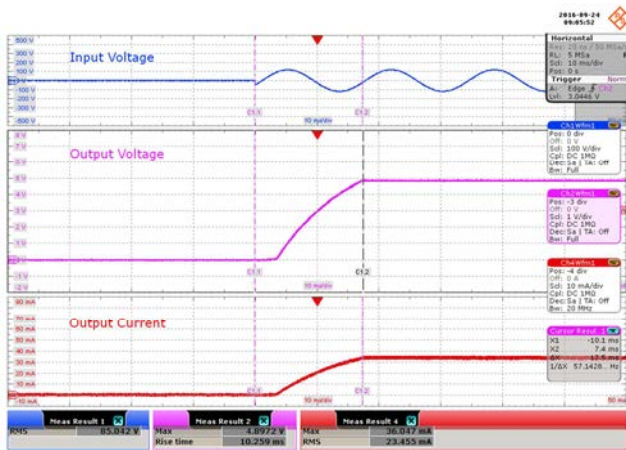
**Figure 16** – 230 VAC Input.  
 Condition: 5V – 35 mA.  
 $V_{RIPPLE}$ , 50 mV / div., 100 ms / div.  
 Zoom, 100  $\mu$ s / div.  
 $V_{RIPPLE(PK-PK)}$ : 46.64 mV.



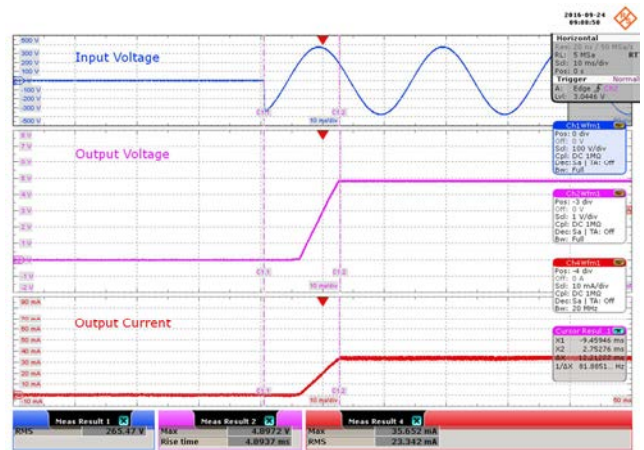
**Figure 17** – 265 VAC Input.  
 Condition: 5 V – 35 mA.  
 $V_{RIPPLE}$ , 50 mV / div., 100 ms / div.  
 Zoom, 100  $\mu$ s / div.  
 $V_{RIPPLE(PK-PK)}$ : 44.269 mV.

## 9.2 Output Voltage Start-up

Measured at the board output terminals with 150 Ω resistive load.



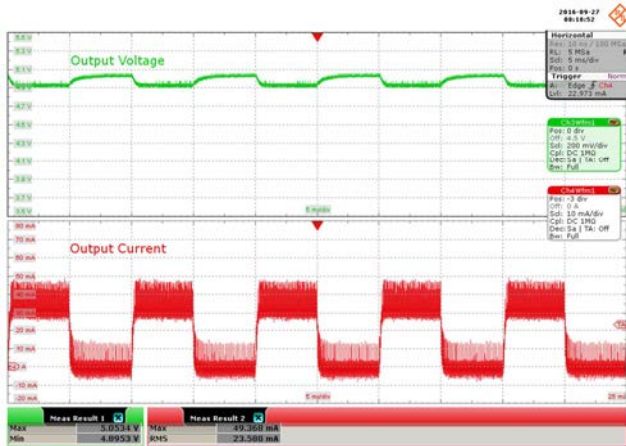
**Figure 18** – 85 VAC Input.  
 Upper:  $V_{IN}$ , 100 V / div.  
 Middle:  $V_{OUT}$ , 1 V / div.  
 Lower:  $I_{OUT}$ , 10 mA / div., 10 ms / div.



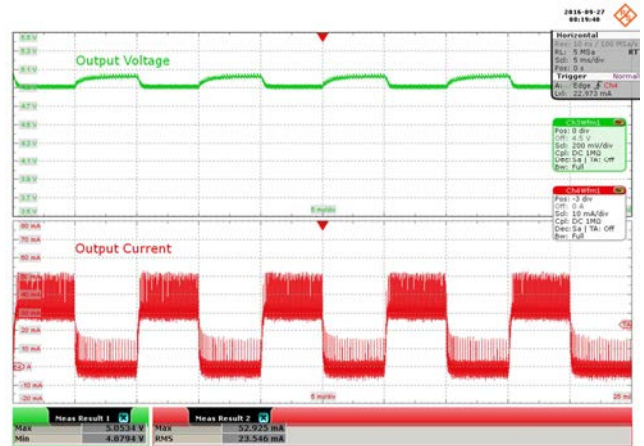
**Figure 19** – 265 VAC Input.  
 Upper:  $V_{IN}$ , 100 V / div.  
 Middle:  $V_{OUT}$ , 1 V / div.  
 Lower:  $I_{OUT}$ , 10 mA / div., 10 ms / div.

## 9.3 Output Load Transient (Dynamic Load)

### 9.3.1 0% - 100% Load

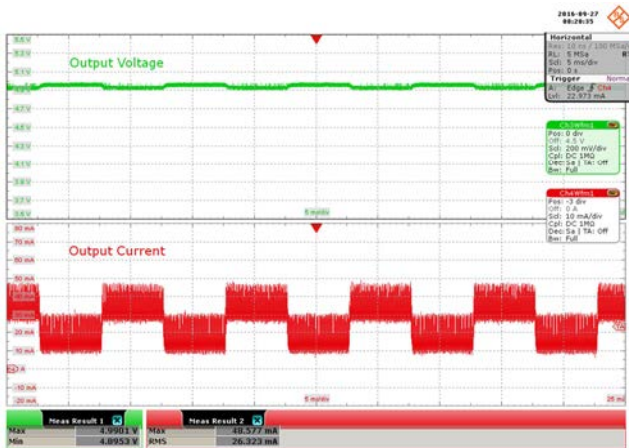


**Figure 20** – 85 VAC Input.  
 $V_{OUT}$ , 200 mV / div.  
 $I_{OUT}$ , 10 mA / div, 5 ms / div.  
 $V_{MAX}$ : 5.0534 V.  
 $V_{MIN}$ : 4.8953 V.

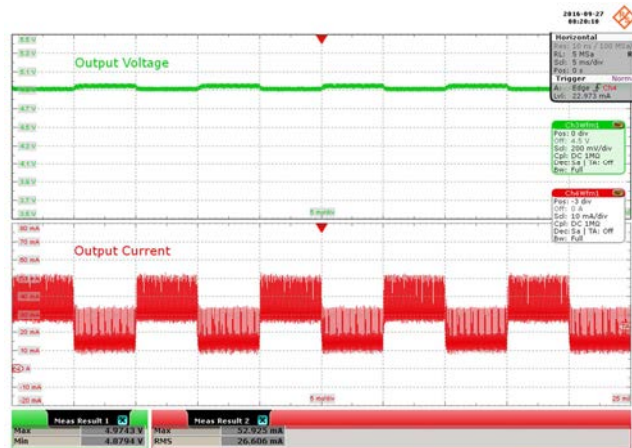


**Figure 21** – 265 VAC Input.  
 $V_{OUT}$ , 200 mV / div.  
 $I_{OUT}$ , 10 mA / div, 5 ms / div.  
 $V_{MAX}$ : 5.0534 V.  
 $V_{MIN}$ : 4.8794 V.

9.3.2 50% - 100% Load



**Figure 22** – 85 VAC Input.  
 $V_{OUT}$ , 200 mV / div.  
 $I_{OUT}$ , 10 mA / div., 5 ms / div.  
 $V_{MAX}$ : 4.9901 V.  
 $V_{MIN}$ : 4.8953 V.

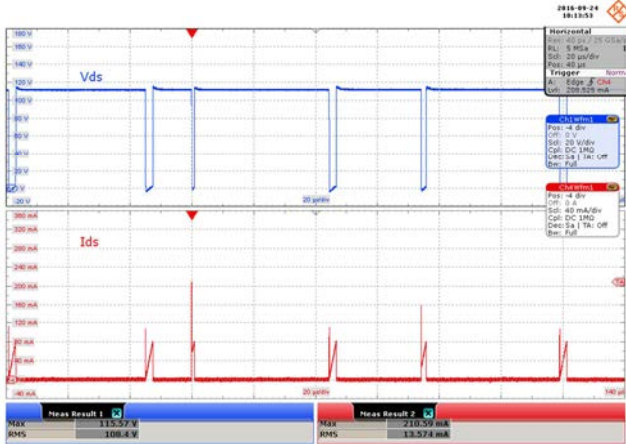


**Figure 23** – 265 VAC Input.  
 $V_{OUT}$ , 200 mV / div.  
 $I_{OUT}$ , 10 mA / div., 5 ms / div.  
 $V_{MAX}$ : 4.9743 V.  
 $V_{MIN}$ : 4.8794 V.

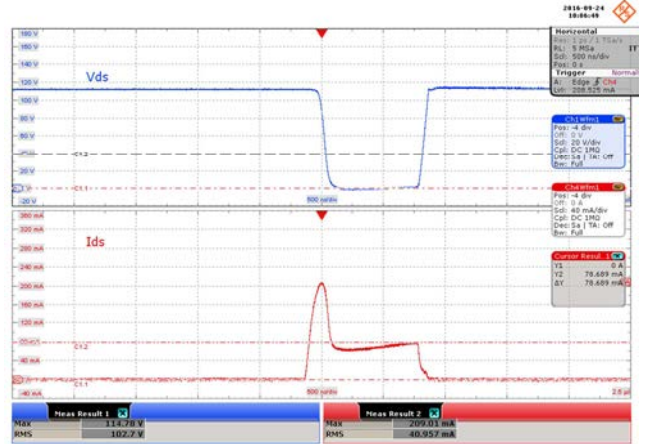
### 9.4 Drain Waveforms

#### 9.4.1 Normal Operation $V_{DS}$ and $I_{DS}$

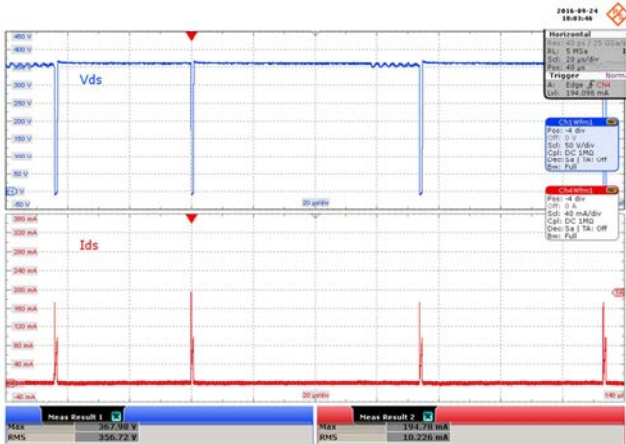
##### 9.4.1.1 100% Load



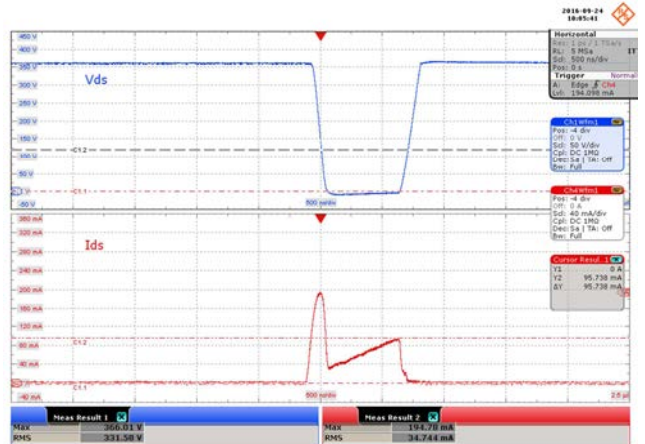
**Figure 24** – 85 VAC Input.  
 Upper:  $V_{DS}$ , 20 V / div.  
 Lower:  $I_{DS}$ , 40 mA / div, 20  $\mu$ s / div.



**Figure 25** – 85 VAC Input.  
 Upper:  $V_{DS}$ , 20 V / div.  
 Lower:  $I_{DS}$ , 40 mA / div., 500 ns / div.  
 $V_{DSMAX}$ : 114.78 V.  
 $I_{DSMAX}$ : 78.689 mA.

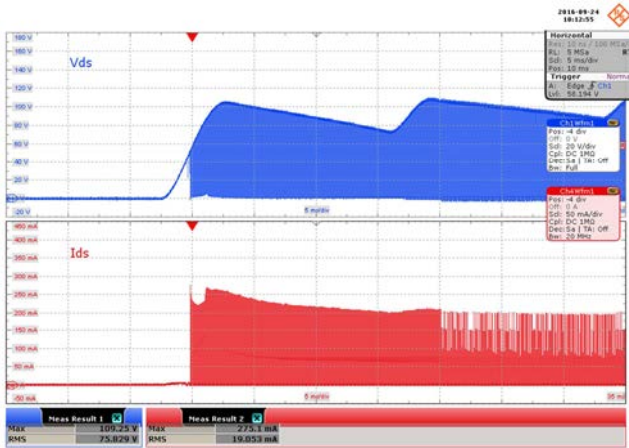


**Figure 26** – 265 VAC Input.  
 Upper:  $V_{DS}$ , 50 V / div.  
 Lower:  $I_{DS}$ , 40 mA / div., 20  $\mu$ s / div.

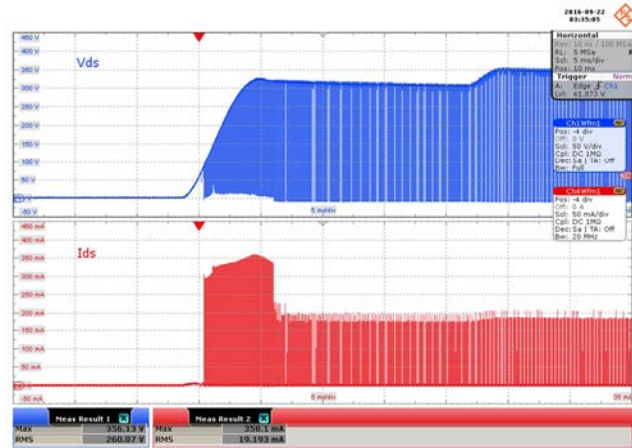


**Figure 27** – 265 VAC Input.  
 Upper:  $V_{DS}$ , 50 V / div.  
 Lower:  $I_{DS}$ , 40 mA / div., 500 ns / div.  
 $V_{DSMAX}$ : 366.01 V.  
 $I_{DSMAX}$ : 95.738 mA.

9.4.2 Start-up Operation  $V_{DS}$  and  $I_{DS}$



**Figure 28** – 85 VAC Input.  
 Upper:  $V_{DS}$ , 20 V / div.  
 Lower:  $I_{DS}$ , 50 mA / div., 5 ms / div.  
 $V_{DSMAX}$ : 109.25 V.  
 $I_{DSMAX}$ : 275.10 mA.



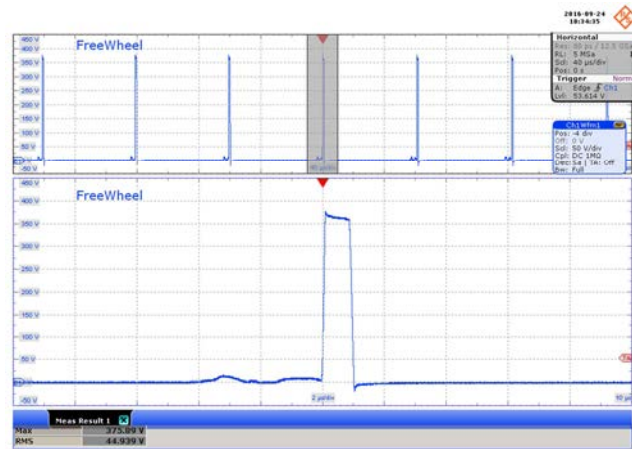
**Figure 29** – 265 VAC Input.  
 Upper:  $V_{DS}$ , 50 V / div.  
 Lower:  $I_{DS}$ , 50 mA / div., 5 ms / div.  
 $V_{DSMAX}$ : 356.13 V.  
 $I_{DSMAX}$ : 358.10 mA.

9.5 *Free Wheel Diode Waveforms*

9.5.1 Normal Operation 100% Load



**Figure 30** – 85 VAC Input.  
 $V_{FWL}$ , 20 V / div, 40  $\mu$ s / div.  
 Zoom: 2  $\mu$ s / div.  
 $I_{FWLMAX}$ : 110.04 V.



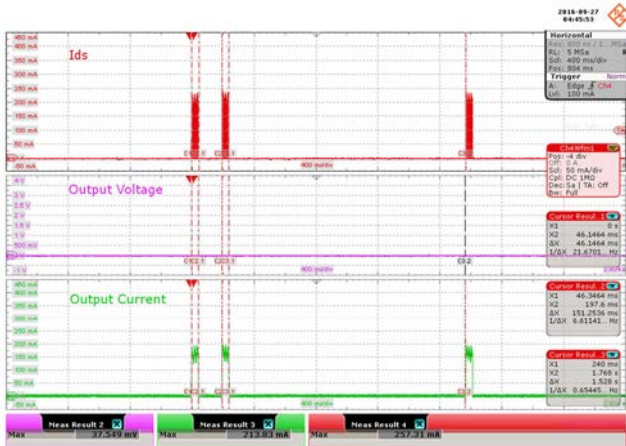
**Figure 31** – 265 VAC Input.  
 $V_{FWL}$ , 50 V / div, 40  $\mu$ s / div.  
 Zoom: 2  $\mu$ s / div.  
 $I_{FWLMAX}$ : 375.09 V.



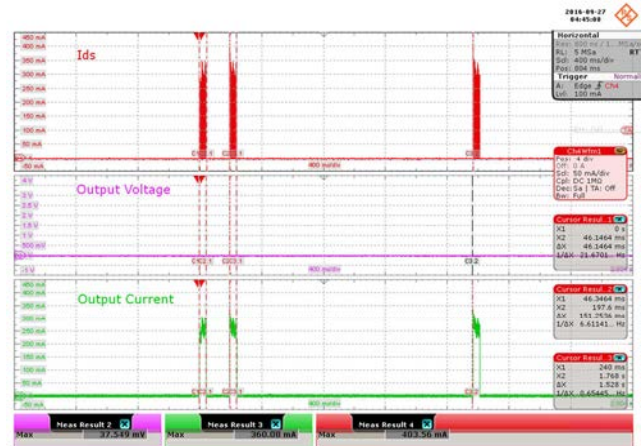
### 9.6 Output Short Waveforms

Short the main output (5 V) and monitor  $I_{DS}$ , output voltage and output current. The first time a fault is asserted the off-time is 150 ms ( $t_{AR(OFF)}$  first off period). If the fault condition persists, subsequent off-times are 1500 ms long ( $t_{AR(OFF)}$  subsequent periods).

#### 9.6.1 Output Short-Circuit Protection



**Figure 32** – 85 VAC Input.  
 Condition: 5 V – Shorted.  
 Upper:  $I_{DS}$ , 50 mA / div.  
 Middle:  $V_{OUT}$ , 500 mV / div.  
 Lower:  $I_{OUT}$ , 50 mA / div., 400 ms / div.



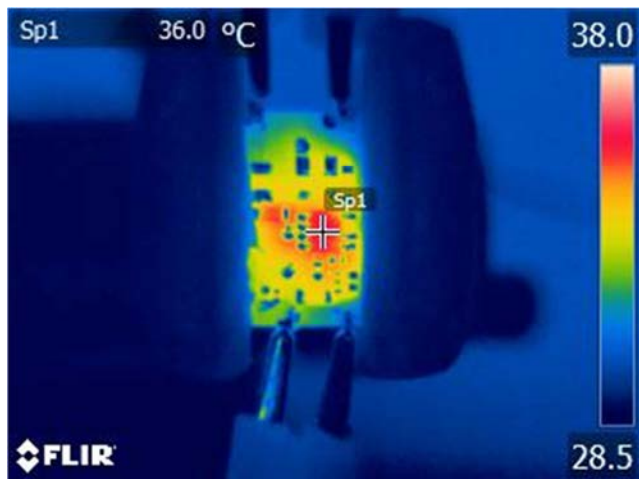
**Figure 33** – 265 VAC Input.  
 Condition: 5 V – Shorted.  
 Upper:  $I_{DS}$ , 50 mA / div.  
 Middle:  $V_{OUT}$ , 500 mV / div.  
 Lower:  $I_{OUT}$ , 50 mA / div., 400 ms / div.

9.7 **Thermal Performance at Room Temperature**

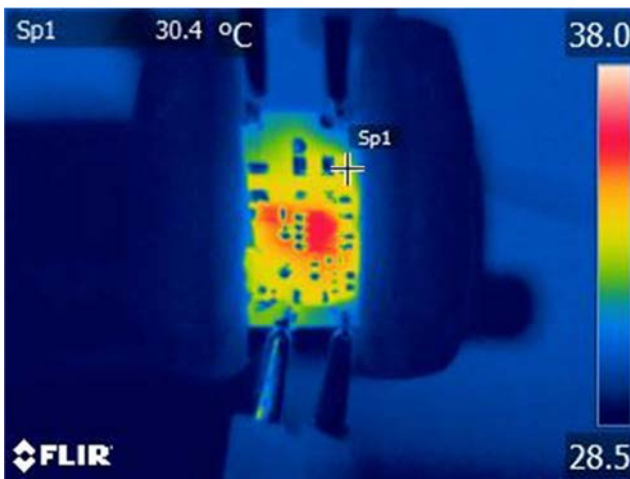
This was done inside an acrylic box under room temperature condition. The board was mounted vertical. The output set to 100% load. Soak the power supply for 2 hours.

9.7.1 Thermal Performance at 85 VAC

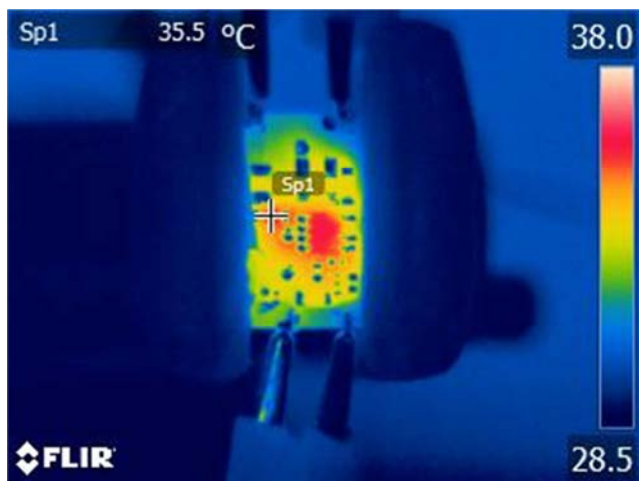
Ambient temperature is 28.0 °C



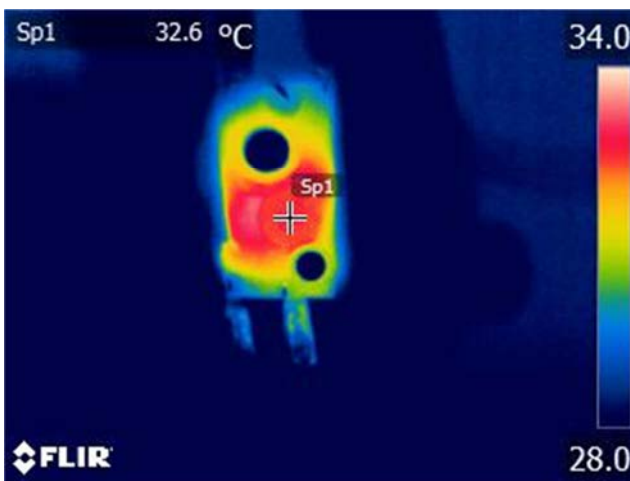
**Figure 34** – LinkSwitch-TN2 (U1).  
Spot: 36.0 °C.



**Figure 35** – Input Rectifier (D1).  
Spot: 30.4 °C.



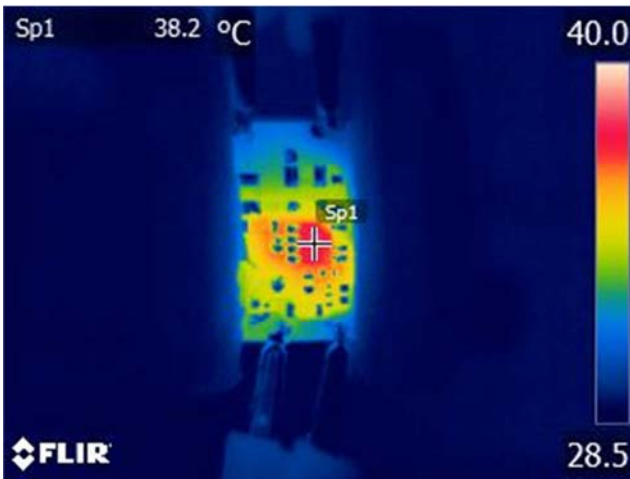
**Figure 36** – Freewheeling Diode (D2).  
Spot: 35.5 °C.



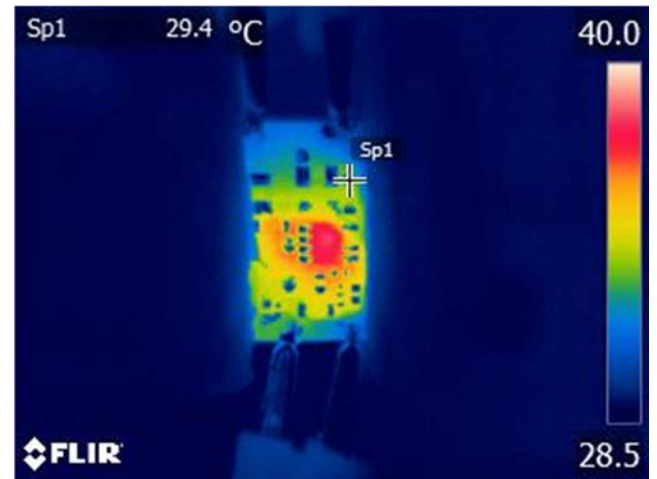
**Figure 37** – Output Inductor (L1).  
Spot: 32.6 °C.

### 9.7.2 Thermal Performance at 265 VAC

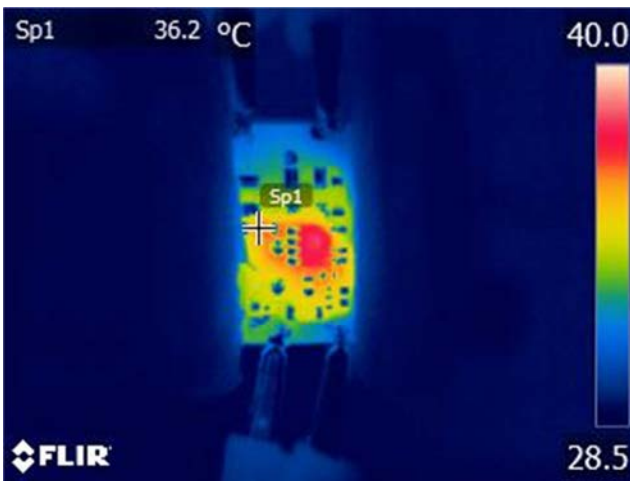
Ambient temperature is 28.0 °C.



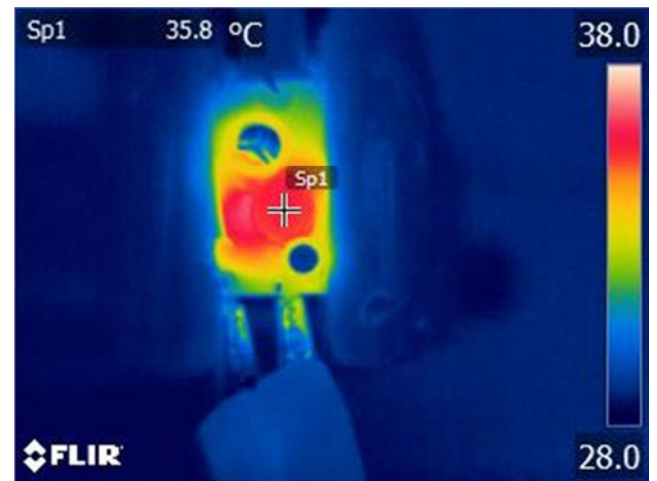
**Figure 38** – LinkSwitch-TN2 (U1).  
Spot: 38.2°C.



**Figure 39** – Input Rectifier (D1).  
Spot: 29.4 °C.



**Figure 40** – Freewheeling Diode (D2).  
Spot: 36.2 °C.



**Figure 41** – Output Inductor (L1).  
Spot: 35.8 °C.

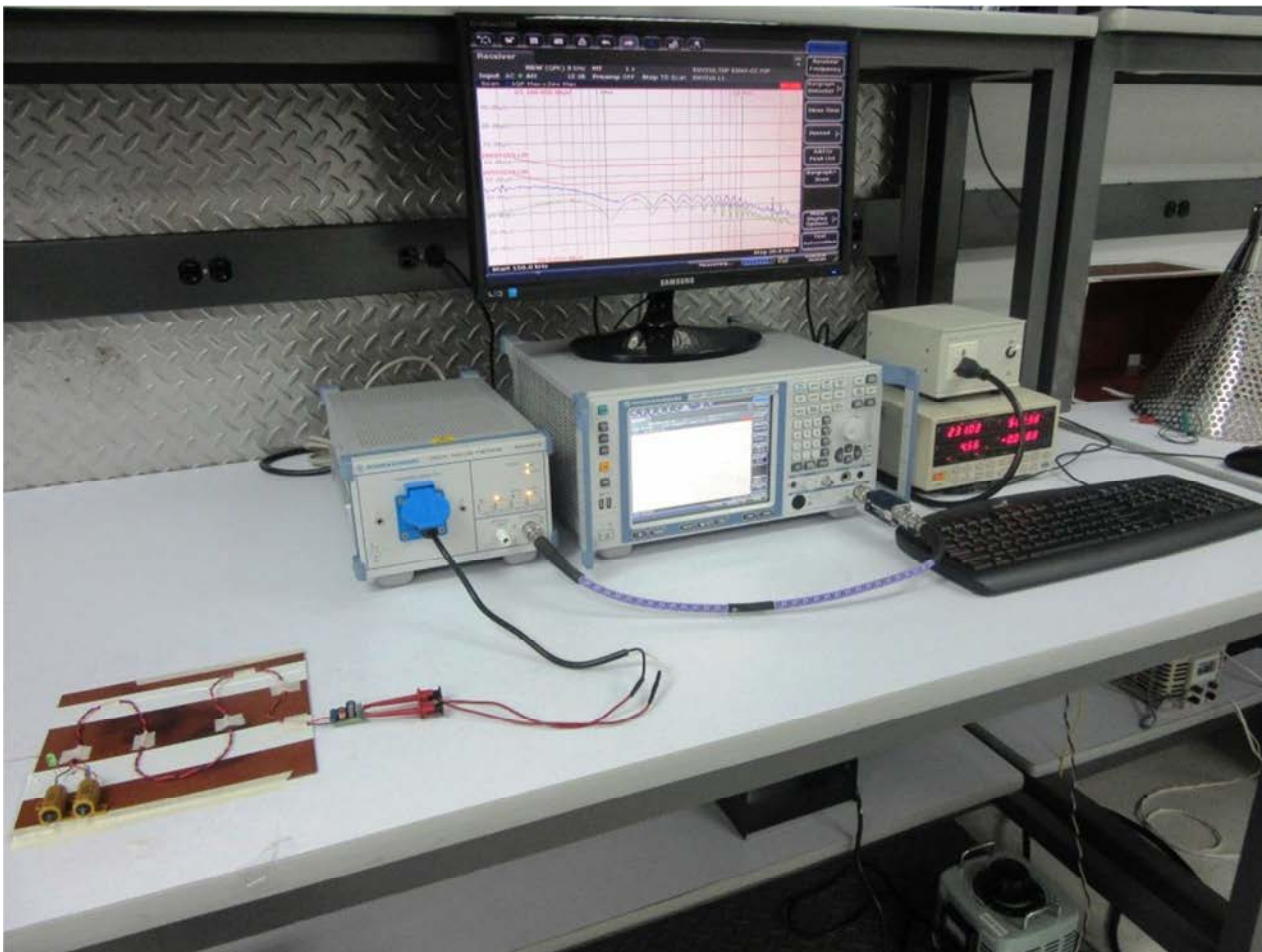
## 10 Conducted EMI

### 10.1 *Test Set-up Equipment*

#### 10.1.1 Equipment and Load Used

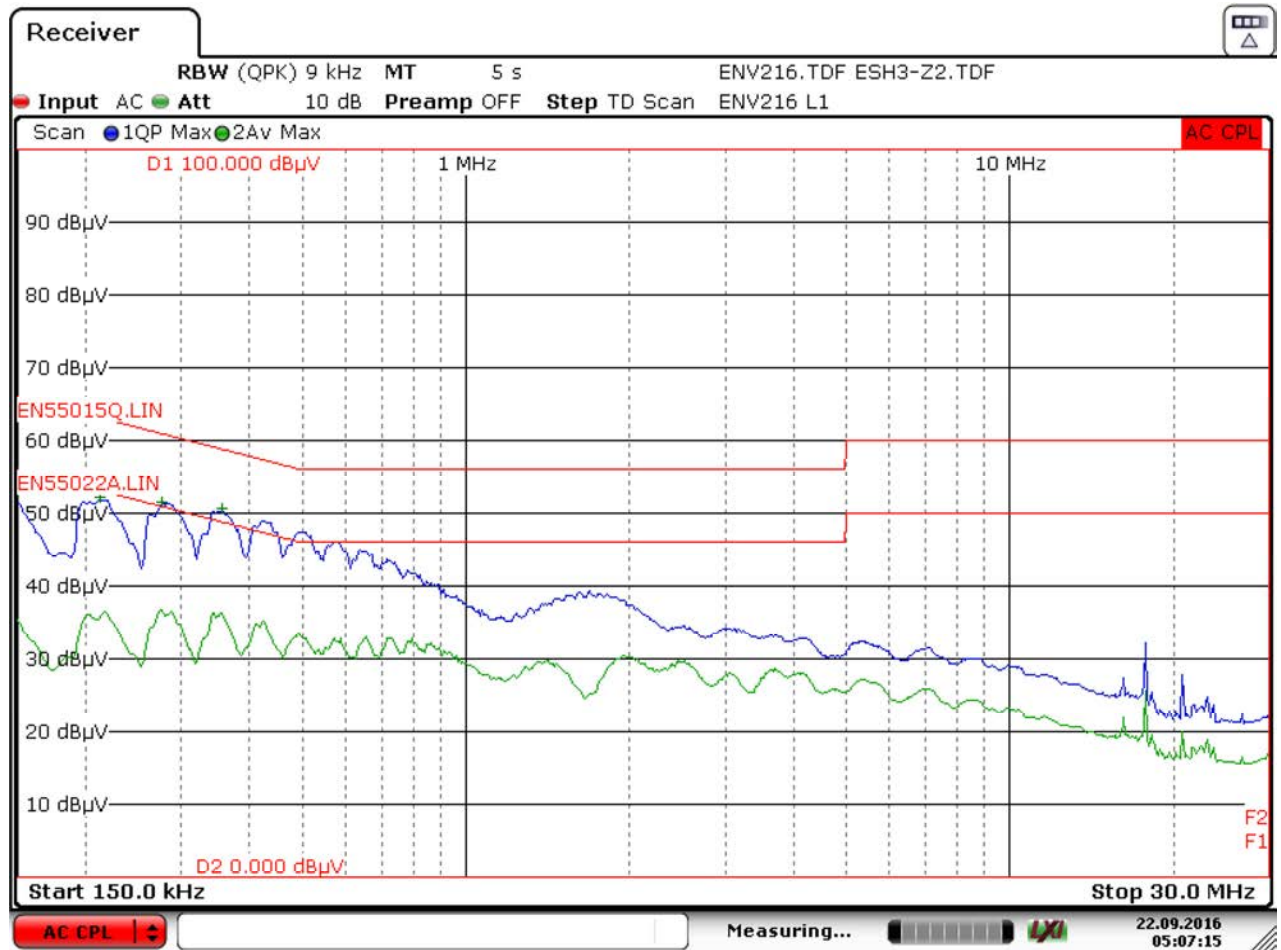
1. Rohde and Schwarz ENV216 two line V-network.
2. Rohde and Schwarz ESRP EMI test receiver.
3. Hioki 3322 power hitester.
4. Chroma measurement test fixture.
5. 142  $\Omega$  resistor load.
6. Input voltage set at 115 VAC and 230 VAC.

### 10.2 *Test Set-up*



### 10.3 Floating Output (QP / AV)

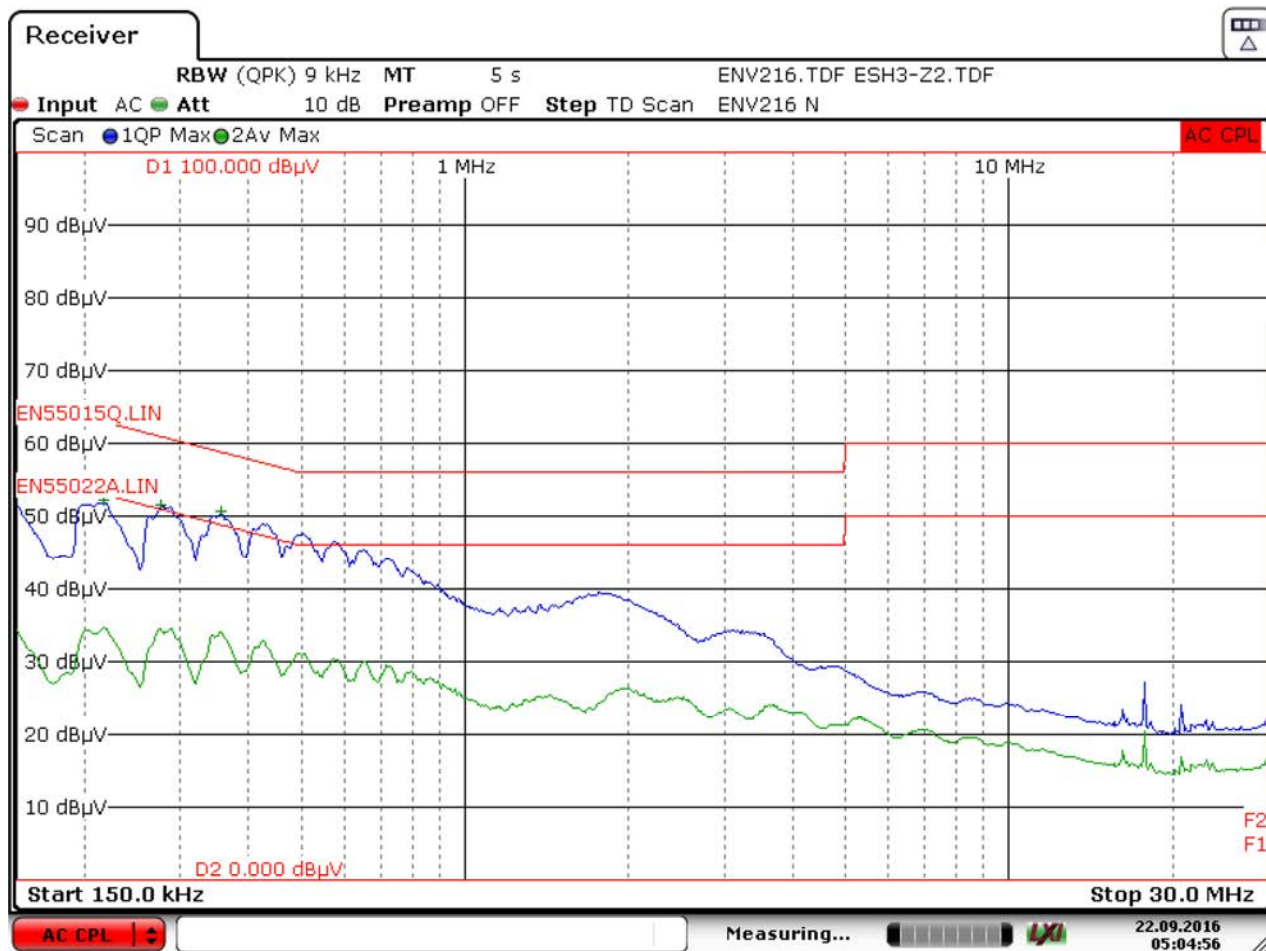
#### 10.3.1 115 VAC



Date: 22.SEP.2016 05:07:14

Figure 42 – Floating Output at 115 VAC, LINE.

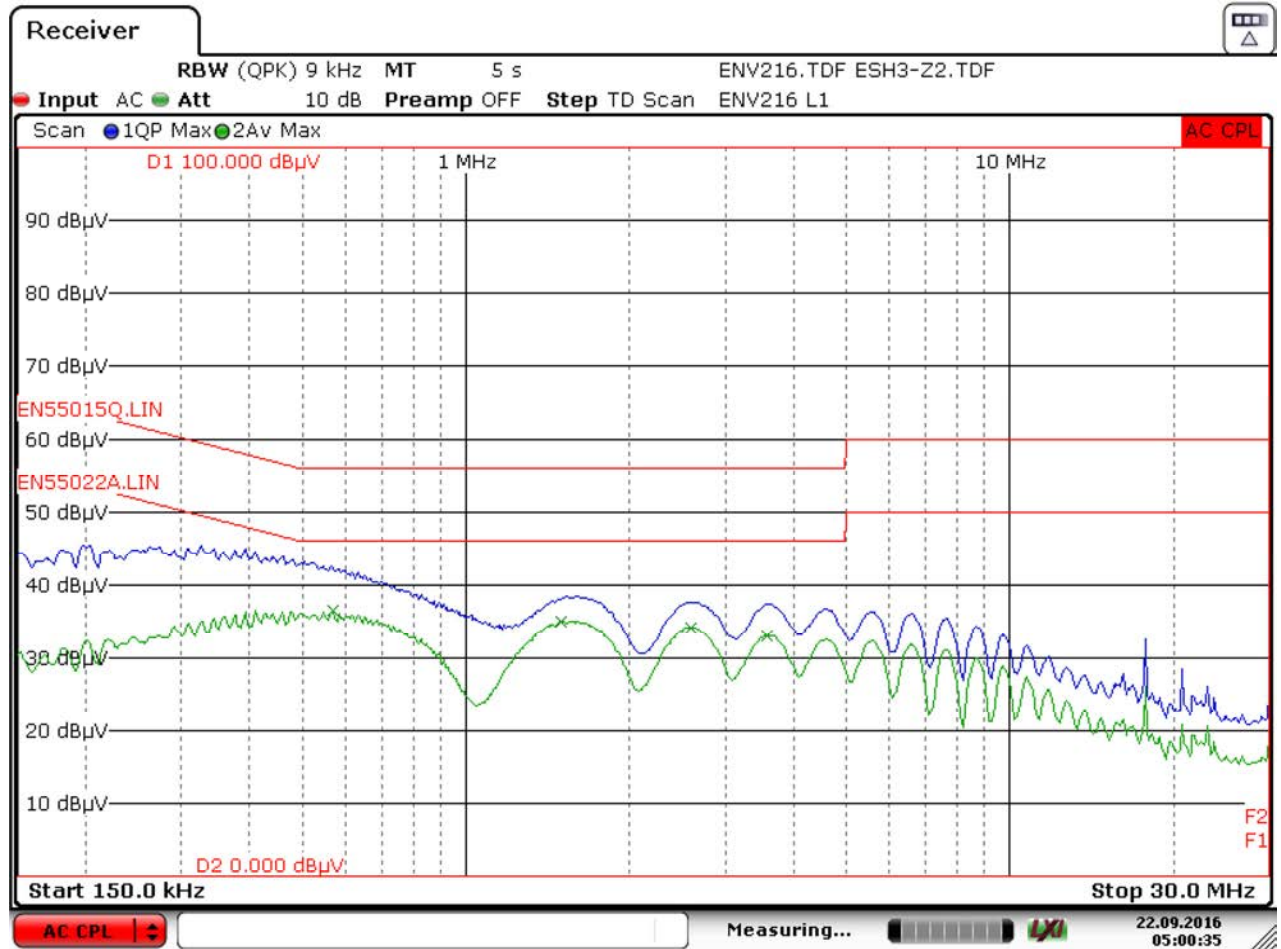




Date: 22.SEP.2016 05:04:56

Figure 43 – Floating Output at 115 VAC, NEUTRAL.

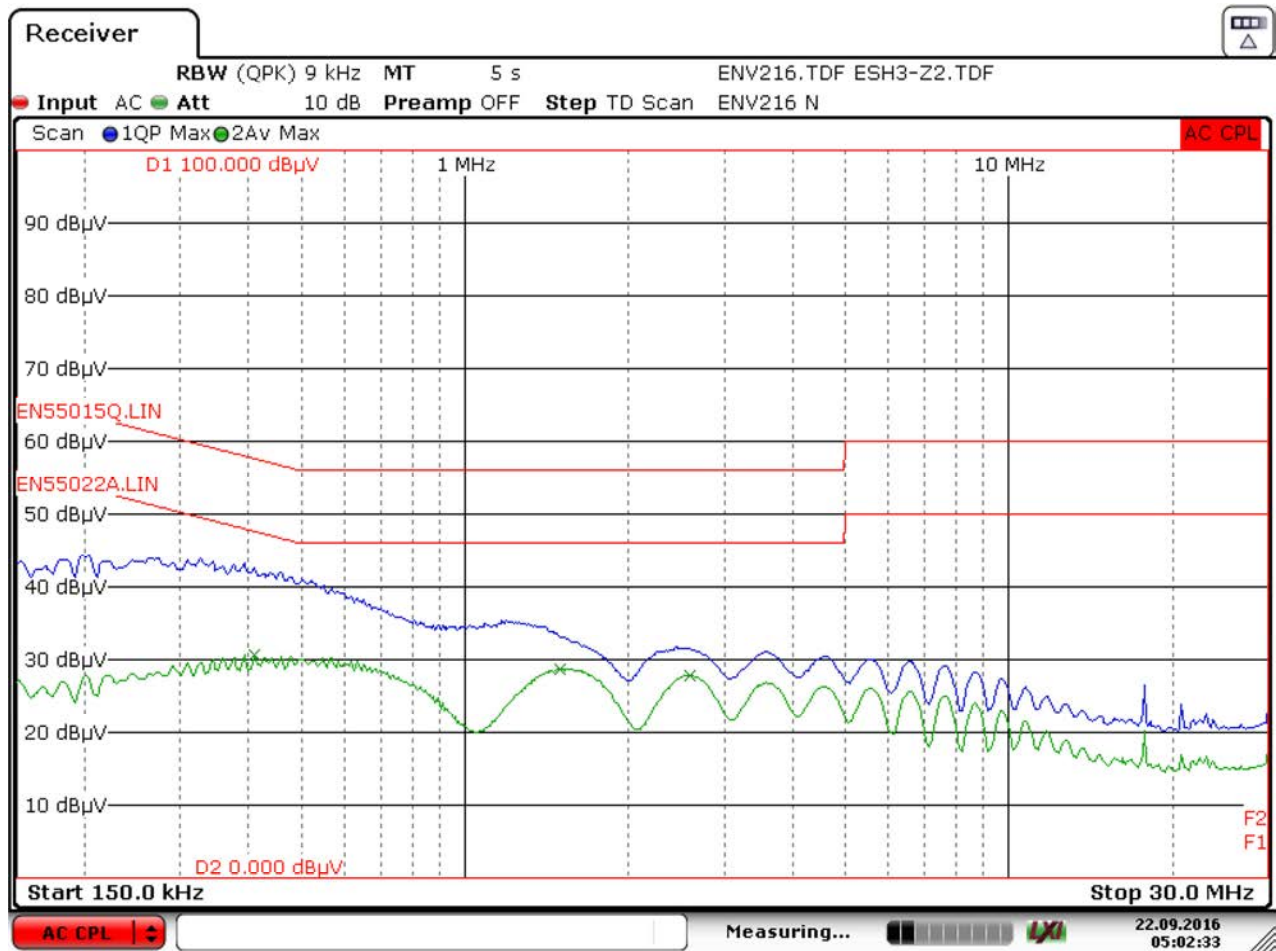
10.3.2 230 VAC



Date: 22.SEP.2016 05:00:35

Figure 44 – Floating Output at 230 VAC, LINE.





Date: 22.SEP.2016 05:02:33

Figure 45 – Floating Output at 230 VAC, NEUTRAL.



## 11 Line Surge

The unit was subjected to  $\pm 1000$  V, differential surge using 10 strikes at each condition. A test failure was defined as a non-recoverable interruption of output requiring repair or recycling of input voltage.

DM Surge Level (V)	Input Voltage (VAC)	Injection Location	Injection Phase (°)	Test Result (Pass/Fail)
+1000	230	L to N	0	Pass
-1000	230	L to N	0	Pass
+1000	230	L to N	90	Pass
-1000	230	L to N	90	Pass
+1000	230	L to N	180	Pass
-1000	230	L to N	180	Pass
+1000	230	L to N	270	Pass
-1000	230	L to N	270	Pass

## 12 Revision History

Date	Author	Revision	Description and Changes	Reviewed
08-Nov-16	AO & CC	1.0	Initial Release.	Apps & Mktg



---

**For the latest updates, visit our website: [www.power.com](http://www.power.com)**

Power Integrations reserves the right to make changes to its products at any time to improve reliability or manufacturability. Power Integrations does not assume any liability arising from the use of any device or circuit described herein. POWER INTEGRATIONS MAKES NO WARRANTY HEREIN AND SPECIFICALLY DISCLAIMS ALL WARRANTIES INCLUDING, WITHOUT LIMITATION, THE IMPLIED WARRANTIES OF MERCHANTABILITY, FITNESS FOR A PARTICULAR PURPOSE, AND NON-INFRINGEMENT OF THIRD PARTY RIGHTS.

**Patent Information**

The products and applications illustrated herein (including transformer construction and circuits' external to the products) may be covered by one or more U.S. and foreign patents, or potentially by pending U.S. and foreign patent applications assigned to Power Integrations. A complete list of Power Integrations' patents may be found at [www.power.com](http://www.power.com). Power Integrations grants its customers a license under certain patent rights as set forth at <http://www.power.com/ip.htm>.

The PI Logo, TOPSwitch, TinySwitch, LinkSwitch, LYTSwitch, InnoSwitch, DPA-Switch, PeakSwitch, CAPZero, SENZero, LinkZero, HiperPFS, HiperTFS, HiperLCS, Qspeed, EcoSmart, Clampless, E-Shield, Filterfuse, FluxLink, StackFET, PI Expert and PI FACTS are trademarks of Power Integrations, Inc. Other trademarks are property of their respective companies. ©Copyright 2015 Power Integrations, Inc.

---

**Power Integrations Worldwide Sales Support Locations****WORLD HEADQUARTERS**

5245 Hellyer Avenue  
San Jose, CA 95138, USA  
Main: +1-408-414-9200  
Customer Service:  
Phone: +1-408-414-9665  
Fax: +1-408-414-9765  
e-mail: [usasales@power.com](mailto:usasales@power.com)

**GERMANY**

Lindwurmstrasse 114  
80337, Munich  
Germany  
Phone: +49-895-527-39110  
Fax: +49-895-527-39200  
e-mail: [eurosales@power.com](mailto:eurosales@power.com)

**JAPAN**

Kosei Dai-3 Building  
2-12-11, Shin-Yokohama,  
Kohoku-ku, Yokohama-shi,  
Kanagawa 222-0033  
Japan  
Phone: +81-45-471-1021  
Fax: +81-45-471-3717  
e-mail: [japansales@power.com](mailto:japansales@power.com)

**TAIWAN**

5F, No. 318, Nei Hu Rd.,  
Sec. 1  
Nei Hu District  
Taipei 11493, Taiwan R.O.C.  
Phone: +886-2-2659-4570  
Fax: +886-2-2659-4550  
e-mail:  
[taiwansales@power.com](mailto:taiwansales@power.com)

**CHINA (SHANGHAI)**

Rm 2410, Charity Plaza, No. 88,  
North Caoxi Road,  
Shanghai, PRC 200030  
Phone: +86-21-6354-6323  
Fax: +86-21-6354-6325  
e-mail: [chinasales@power.com](mailto:chinasales@power.com)

**INDIA**

#1, 14<sup>th</sup> Main Road  
Vasanthanagar  
Bangalore-560052  
India  
Phone: +91-80-4113-8020  
Fax: +91-80-4113-8023  
e-mail: [indiasales@power.com](mailto:indiasales@power.com)

**KOREA**

RM 602, 6FL  
Korea City Air Terminal B/D,  
159-6  
Samsung-Dong, Kangnam-Gu,  
Seoul, 135-728 Korea  
Phone: +82-2-2016-6610  
Fax: +82-2-2016-6630  
e-mail: [koreasales@power.com](mailto:koreasales@power.com)

**UK**

Cambridge Semiconductor,  
a Power Integrations company  
Westbrook Centre, Block 5,  
2nd Floor  
Milton Road  
Cambridge CB4 1YG  
Phone: +44 (0) 1223-446483  
e-mail: [eurosales@power.com](mailto:eurosales@power.com)

**CHINA (SHENZHEN)**

17/F, Hivac Building, No. 2, Keji  
Nan 8th Road, Nanshan District,  
Shenzhen, China, 518057  
Phone: +86-755-8672-8689  
Fax: +86-755-8672-8690  
e-mail: [chinasales@power.com](mailto:chinasales@power.com)

**ITALY**

Via Milanese 20, 3<sup>rd</sup>. Fl.  
20099 Sesto San Giovanni (MI)  
Italy  
Phone: +39-024-550-8701  
Fax: +39-028-928-6009  
e-mail: [eurosales@power.com](mailto:eurosales@power.com)

**SINGAPORE**

51 Newton Road,  
#19-01/05 Goldhill Plaza  
Singapore, 308900  
Phone: +65-6358-2160  
Fax: +65-6358-2015  
e-mail: [singaporesales@power.com](mailto:singaporesales@power.com)

