



Design Example Report

Title	2.4W Charger using TNY264P
Specification	Input: 85 - 265 VAC Output: 6V / 0.4A
Application	Cell Phone Charger
Author	Power Integrations Applications Department
Document Number	DER-3
Date	February 4, 2004
Revision	1.0

Summary and Features

This report details the design of an isolated Flyback converter for Wall mount adapter.

- Uses TinySwitch TNY264
- Universal input voltage
- Typical Efficiency 62 %
- Meets EN550022 Class B EMI tests with No Y1 capacitor
- Very low earth leakage current

The products and applications illustrated herein (including circuits external to the products and transformer construction) may be covered by one or more U.S. and foreign patents or potentially by pending U.S. and foreign patent applications assigned to Power Integrations. A complete list of Power Integrations' patents may be found at www.powerint.com

Table Of Contents

1	Introduction.....	4
2	Power Supply Specification.....	4
3	Schematic.....	5
4	PCB Layout.....	6
5	Bill Of Materials.....	7
6	Transformer.....	8
6.1	Transformer Winding.....	8
6.2	Electrical Specifications.....	8
6.3	Transformer Construction.....	9
6.4	Winding Instructions.....	9
6.5	Materials.....	10
6.6	Design Notes:.....	10
7	Performance Data.....	11
7.1	Efficiency.....	11
7.2	Regulation.....	12
7.3	No Load Input Power.....	12
7.4	Output Ripple Measurements.....	13
7.4.1	Ripple Measurement Technique.....	13
7.4.2	Output Voltage Ripple.....	14
8	EMI Tests.....	15
9	Revision History.....	17



List Of Figures

Figure 1 – Flyback Converter – 2.4W 6V 0.4A.....	5
Figure 2 – PCB Layout	6
Figure 3 – Transformer Winding.....	8
Figure 4 – Transformer construction	9
Figure 5 – Efficiency Vs Output Current.....	11
Figure 6 – Load Regulation	12
Figure 7 – No Load Input Power.....	12
Figure 8 – Oscilloscope Probe Prepared for Ripple Measurement.....	13
Figure 9 – Oscilloscope Probe with Probe Master 5125BA BNC Adapter.....	13
Figure 10 – Output Voltage Ripple (worst case) at $V_{in} = 264 \text{ Vac}$, $V_o = 6.0 \text{ V}$, $I_o = 400 \text{ mA}$	14
Figure 11 – EN55022 Class B, Line, artificial hand connected to output return	15
Figure 12 – EN55022 Class B, Neutral, artificial hand connected to output return.....	15
Figure 13 – EN55022 Class B, Line, with out artificial hand connected to output return	16
Figure 14 – EN55022 Class B, Neutral, with out artificial hand connected to output return	16

List Of Tables

Table 1 – Power Supply Specification	4
Table 2 – Bill of Materials.....	7
Table 3 – Transformer BOM.....	10

Important Notes:

Although this board is designed to satisfy safety isolation requirements, the engineering prototype has not been agency approved. Therefore, all testing should be performed using an isolation transformer to provide the AC input to the prototype board.

Design Reports contain a power supply design specification, schematic, bill of materials, and transformer documentation. Performance data and typical operation characteristics are included. Typically only a single prototype has been built.



1 Introduction

This document is an engineering report giving performance characteristics of an isolated Flyback converter with universal input voltage and 6V 0.4A output CV/ CC characteristics. This design uses TinySwitch – an integrated IC comprising a high voltage MOSFET, PWM controller.

This document contains the power supply specification, schematic, and bill of materials, transformer documentation, printed circuit layout, and performance data.

2 Power Supply Specification

Description	Symbol	Min	Typ	Max	Units	Comment
Input Voltage	V_{IN}	85		264	Vac	
Output Output Voltage 1 Output Ripple Voltage 1 Output Current 1	V_{OUT1} $V_{RIPPLE1}$ I_{OUT1}	5.7	6.0	6.3 100 0.4	V mV A	at 400 mA load 20 MHz Bandwidth
Total Output Power Continuous Output Power	P_{OUT}			2.4	W	
Constant Current Limit			0.4		A	
Conducted EMI Margin		5			dB	EN550022 B, FCC B
Efficiency	η		50		%	At full load
Ambient Temperature	T_{AMB}	-10		40	°C	Free convection, Sea level

Table 1 – Power Supply Specification



4 PCB Layout

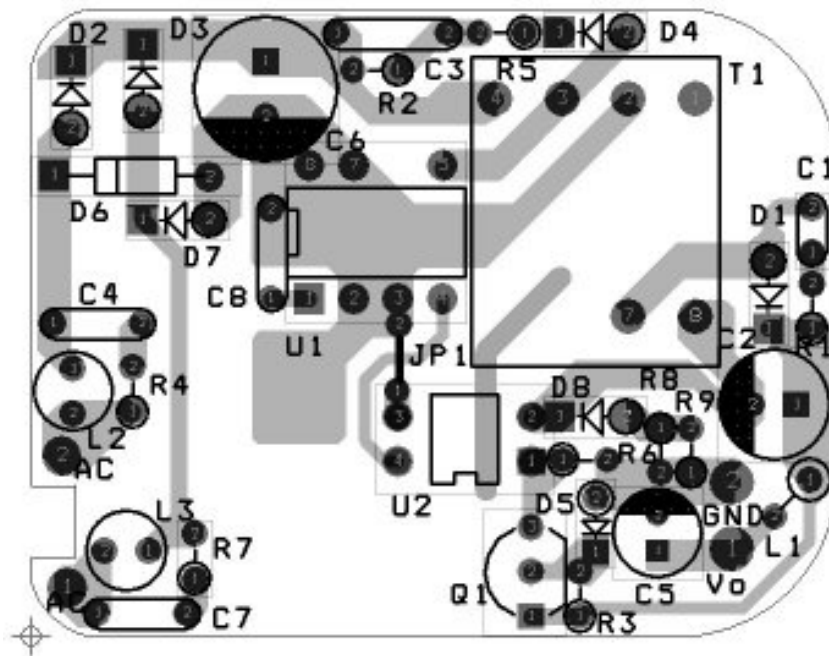

Figure 2 – PCB Layout



5 Bill Of Materials

Item	Quantity	Reference	Part
1	1	C1	470 pF, 100V, Ceramic capacitor
2	1	C2	220 μ F, 10V, Low ESR AL capacitor
3	1	C3	2200 pF, 1KV, Ceramic capacitor
4	1	C4	100 pF, 1KV, Ceramic capacitor
5	1	C5	100 μ F, 10V, Low ESR AL capacitor
6	1	C6	4.7 μ F, 400V, AL capacitor
7	1	C7	100 pF, 1KV, Ceramic capacitor
8	1	C8	0.1 μ F, 50V, Ceramic capacitor
9	1	D1	11DQ06, 60V, 1.1A Schottky diode
10	4	D2, D3, D6, D7	1N4005, 600V, 1A GP diode
11	1	D4	1N4937, 600V, 1A, FR diode
12	1	D5	BZX79C5.6V, 5.6V Zener diode
13	1	D8	1N4001, 100V, 1A, GP Diode
14	1	L1	Large Ferrite Bead
15	1	L2	1 mH, Inductor
16	1	L3	1mH, Inductor
17	1	Q1	2N3906, PNP Transistor
18	1	R1	51 Ω , 1/4W, 5%
19	1	R2	200 K Ω , 1/4W, 5%
20	1	R3	330 Ω , 1/8W, 5%
21	2	R4, R7	10 K Ω , 1/8W, 5%
22	1	R5	200 Ω , 1/8W, 5%
23	1	R6	100 Ω , 1/8W, 5%
24	1	R8	1.5 Ω , 1/8W, 5%
25	1	R9	1.5 Ω , 1/8W, 5%
26	1	T1	Flyback Transformer
27	1	U1	TNY264, TinySwitch
28	1	U2	LTV817A, Optocoupler

Table 2 – Bill of Materials



6 Transformer

6.1 Transformer Winding

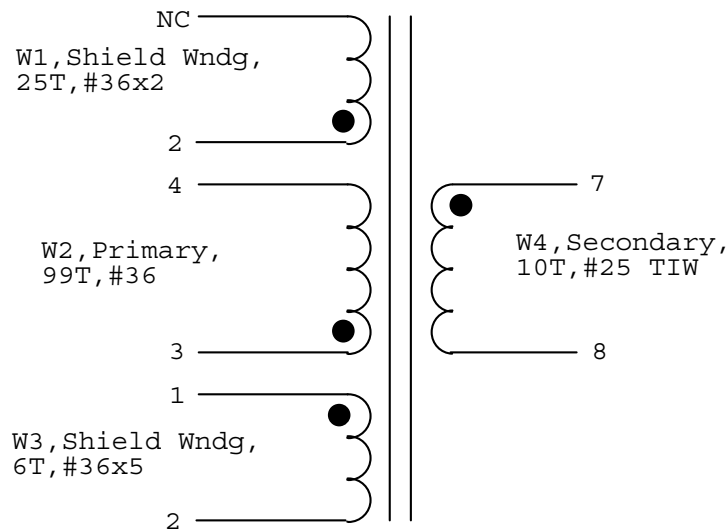

Figure 3 – Transformer Winding

6.2 Electrical Specifications

Electrical Strength	60Hz 1minute, from Pins 1-4 to Pins 7-8	3 kV for 1 minute
Primary Inductance (Pin 3 to Pin 4)	All windings open	1.31 mH – 1.6 mH
Resonant Frequency	All windings open	300 kHz min.
Primary Leakage Inductance	L ₃₄ with pins 5-6 shorted	40 μH max.



6.3 Transformer Construction

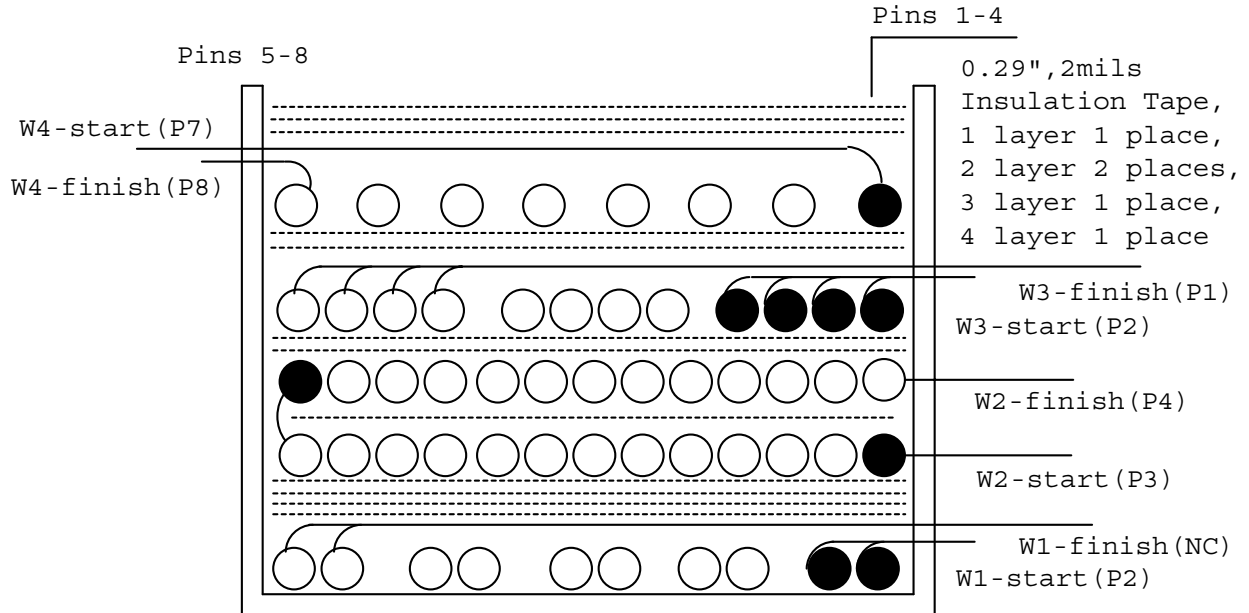

Figure 4 – Transformer construction

6.4 Winding Instructions

Place the bobbin on the winding machine with pins 1-4 on the right side and pins 5-8 on the left side.

W1 (Shield)	Wind 25 turns from right to left with # 36 x 2 (bifilar) AWG magnet wire starting from pin 2 and leave the finishing end open.
Basic Insulation	4 layers of tape for insulation.
W2 (Primary Winding)	Wind 99 turns in 2 layers with # 36 AWG magnet wire – first layer 50T from right to left starting from pin 3 – one layer of insulation tape – second layer 49T from left to right and finishing at pin 4.
Basic Insulation	2 layers of tape for insulation.
W3 (Shield)	Wind 6 turns with #36 x 5 (penta-filar) magnet wire from right to left starting from 2 and finishing at 1.
Basic Insulation	2 layers of tape for insulation.
W4 (Secondary Winding)	Wind 10 turns with # 25 triple insulated wire from right to left starting temporarily from 1 and finishing at 8. Bring the starting end from pin 1 to pin 7.
Outer Insulation	3 layers of tape for insulation.
Core Assembly	Assemble and secure core halves.
Final Assembly	Impregnate transformer uniformly with varnish.

6.5 Materials

Item	Description
[1]	Core: EE13, PC40EE13, TDK Gapped for $A_L = 148 \text{ nH/T}^2$
[2]	Bobbin: Horizontal 8 pins
[3]	Magnet Wire: #36 AWG
[4]	Triple Insulated wire: # 25 AWG
[5]	Tape: 3M 1298 Polyester Film (white) 0.29" x 2 mils
[6]	Varnish

Table 3 – Transformer BOM

6.6 Design Notes:

Power Integrations Device	TNY264
Frequency of Operation	132 KHz
Mode	Continuous/ discontinuous
Peak Current	0.25 A
Reflected Voltage (Secondary to Primary)	75 V
Maximum AC Input Voltage	264 V
Minimum AC Input Voltage	85 V



7 Performance Data

All measurements are performed at room temperature unless otherwise specified. The output voltages are measured at the end of a 6-foot cable with 0.2 Ω total resistance.

7.1 Efficiency

The measurements are made for various load and line conditions. The efficiencies are calculated and shown in Figure 5.

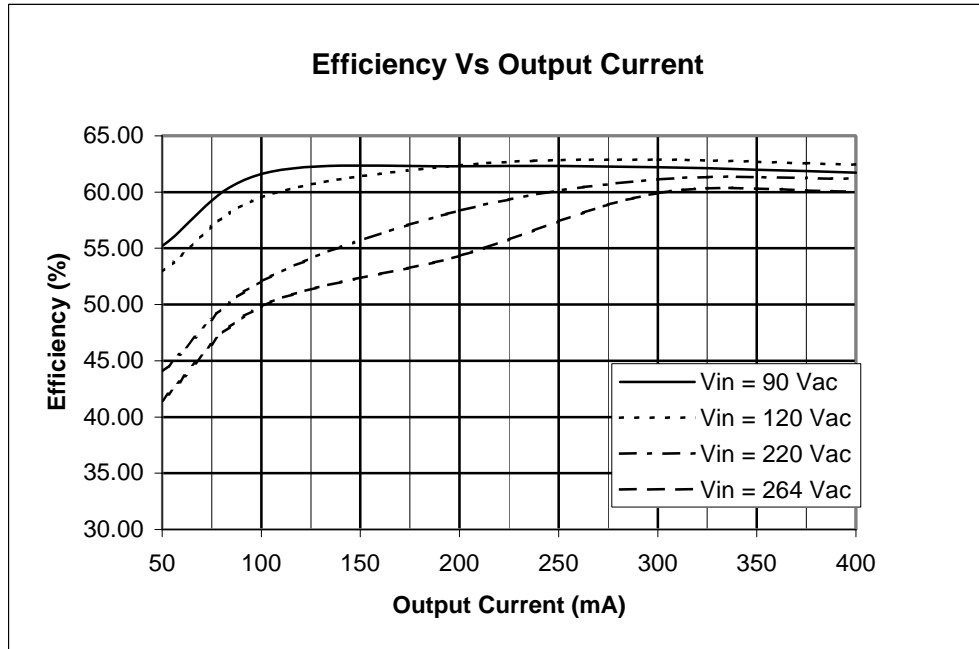

Figure 5 – Efficiency Vs Output Current



7.2 Regulation

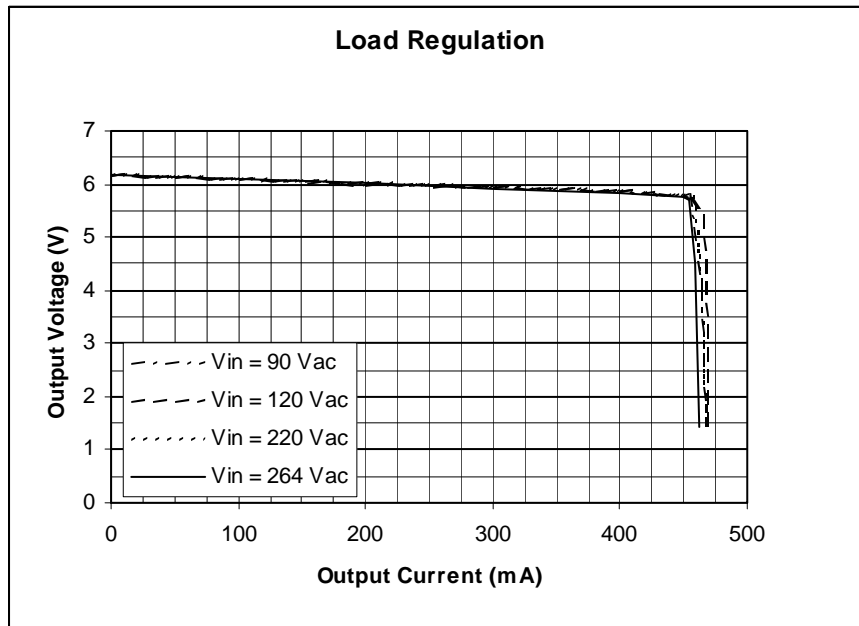

Figure 6 – Load Regulation

7.3 No Load Input Power

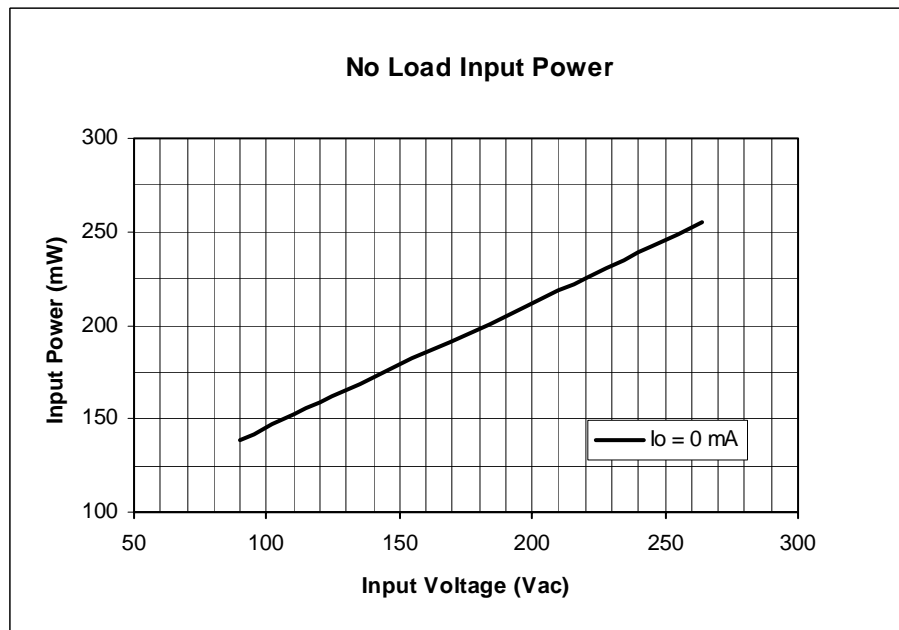

Figure 7 – No Load Input Power



7.4 Output Ripple Measurements

7.4.1 Ripple Measurement Technique

For DC output ripple measurements, a modified oscilloscope test probe must be utilized in order to reduce spurious signals due to pickup. Details of the probe modification are provided in Figure 8 and Figure 9.

The 5125BA probe adapter is affixed with two capacitors tied in parallel across the probe tip. The capacitors include one (1) 0.1 μF /50 V ceramic type and one (1) 1.0 μF /50 V aluminum electrolytic. *The aluminum electrolytic type capacitor is polarized, so proper polarity across DC outputs must be maintained (see below).*

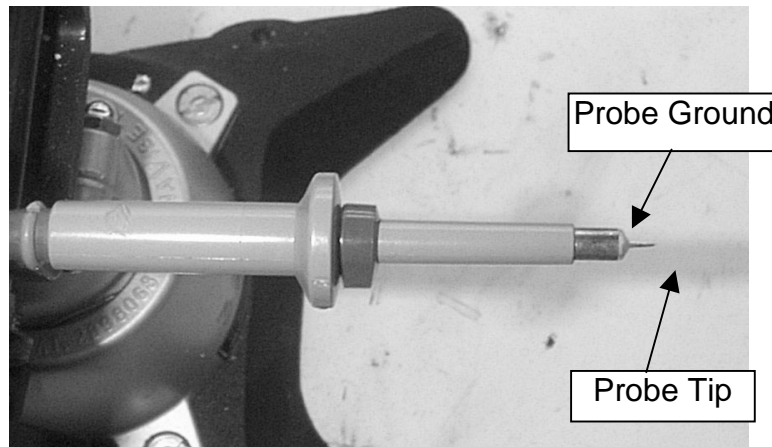

Figure 8 – Oscilloscope Probe Prepared for Ripple Measurement.
(End Cap and Ground Lead Removed)

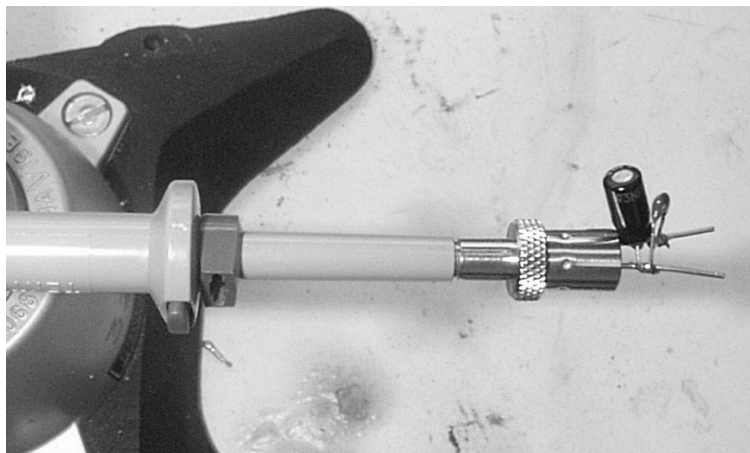

Figure 9 – Oscilloscope Probe with Probe Master 5125BA BNC Adapter

(Modified with wires for probe ground for ripple measurement, and two parallel decoupling capacitors added).

7.4.2 Output Voltage Ripple

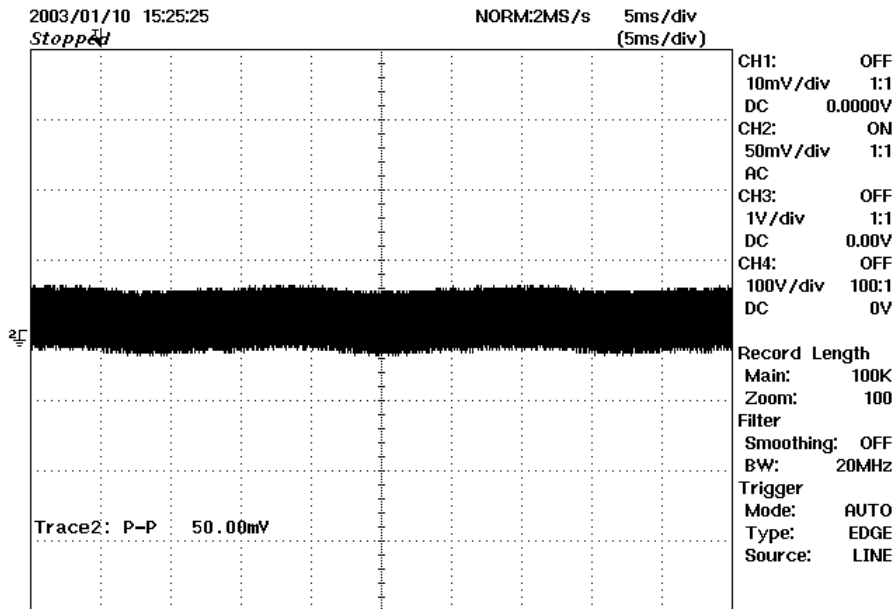

Figure 10 – Output Voltage Ripple (worst case) at $V_{in} = 264 \text{ Vac}$, $V_o = 6.0 \text{ V}$, $I_o = 400 \text{ mA}$



8 EMI Tests

The EMI tests are done at 220 Vac input and 15 Ω (400 mA) load.

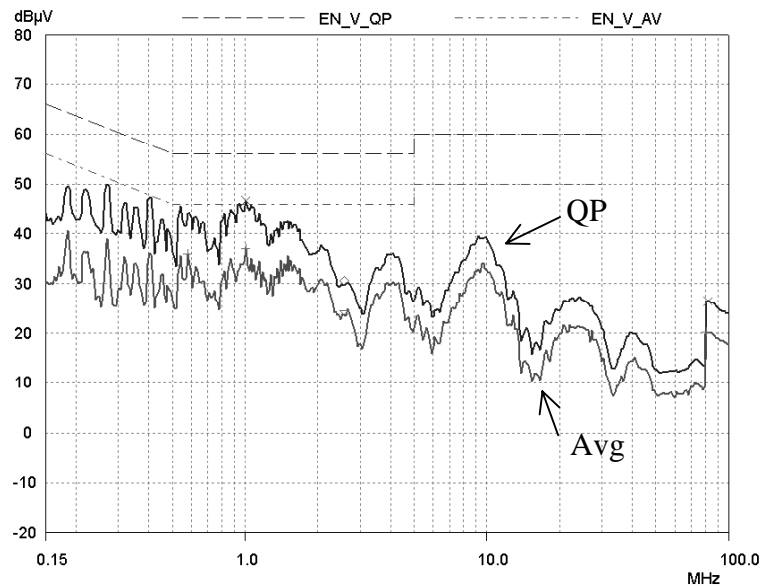

Figure 11 – EN55022 Class B, Line, artificial hand connected to output return

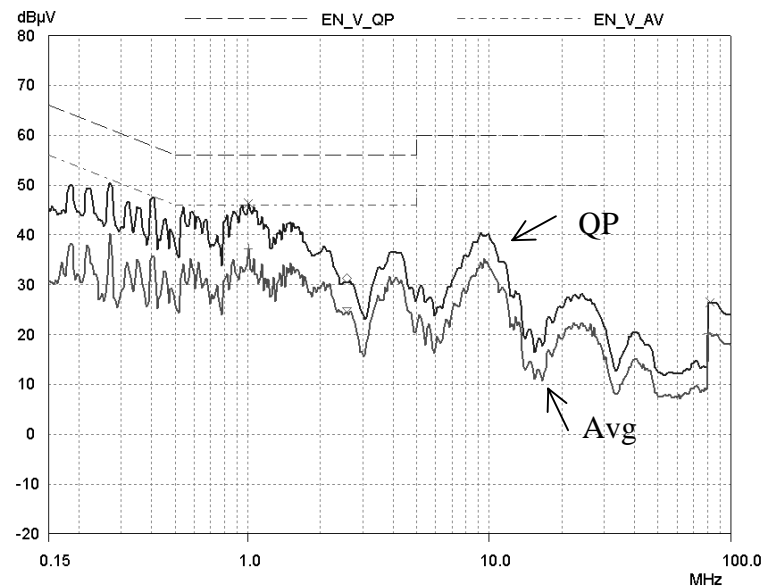

Figure 12 – EN55022 Class B, Neutral, artificial hand connected to output return



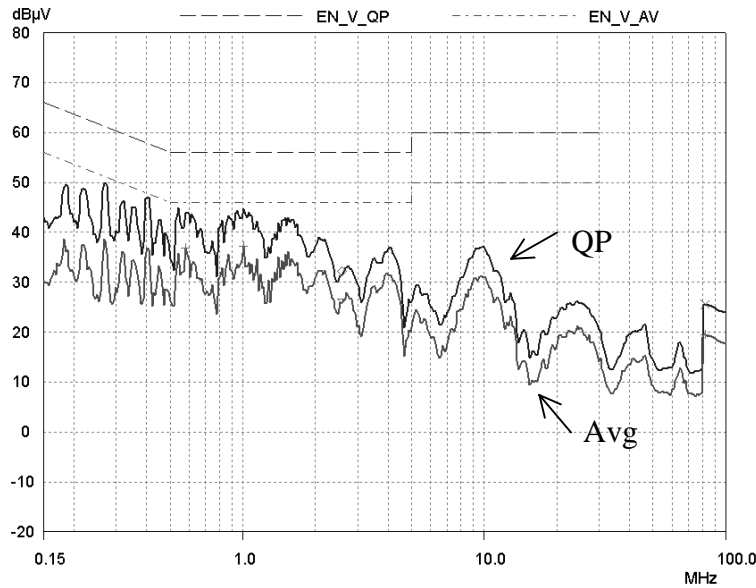

Figure 13 – EN55022 Class B, Line, with out artificial hand connected to output return

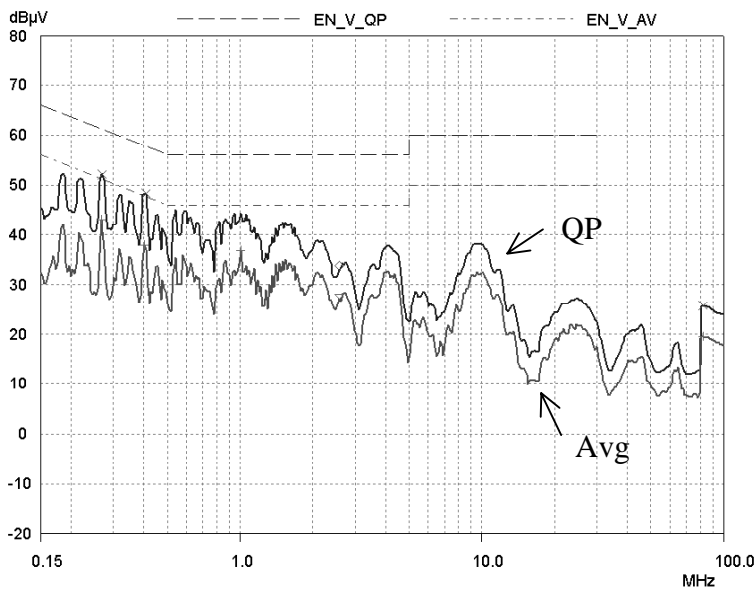

Figure 14 – EN55022 Class B, Neutral, with out artificial hand connected to output return



9 Revision History

Date	Author	Revision	Description & changes	Reviewed
February 4, 2004	MJ	1.0	Initial release	AM/VC



Notes



For the latest updates, visit our website: www.powerint.com

Power Integrations reserves the right to make changes to its products at any time to improve reliability or manufacturability. Power Integrations does not assume any liability arising from the use of any device or circuit described herein, nor does it convey any license under its patent rights or the rights of others.

The products and applications illustrated herein (including circuits external to the products and transformer construction) may be covered by one or more U.S. and foreign patents or potentially by pending U.S. and foreign patent applications assigned to Power Integrations. A complete list of Power Integrations' patents may be found at www.powerint.com.

The PI Logo, **TOPSwitch**, **TinySwitch**, **LinkSwitch**, and **EcoSmart** are registered trademarks of Power Integrations, Inc. **PI Expert** and **DPA-Switch** are trademarks of Power Integrations, Inc.
© Copyright 2003, Power Integrations, Inc.

**WORLD HEADQUARTERS
NORTH AMERICA - WEST**
Power Integrations
5245 Hellyer Avenue
San Jose, CA 95138 USA.
Main: +1•408•414•9200
Customer Service:
Phone: +1•408•414•9665
Fax: +1•408•414•9765

**NORTH AMERICA - EAST
& SOUTH AMERICA**
Power Integrations, Inc.
Eastern Area Sales Office
1343 Canton Road, Suite C1
Marietta, GA 30066 USA
Phone: +1•770•424•5152
Fax: +1•770•424•6567

EUROPE & AFRICA
Power Integrations (Europe) Ltd.
Centennial Court
Easthampstead Road
Bracknell
Berkshire RG12 1YQ,
United Kingdom
Phone: +44•1344•462•301
Fax: +44•1344•311•732

TAIWAN
Power Integrations International
Holdings, Inc.
2F, #508, Chung Hsiao E. Rd.,
Sec. 5,
Taipei 105, Taiwan
Phone: +886•2•2727•1221
Fax: +886•2•2727•1223

CHINA
Power Integrations
International
Holdings, Inc.
Rm# 1705, Bao Hua Bldg.
1016 Hua Qiang Bei Lu
Shenzhen Guangdong,
518031
Phone: +86•755•367•5143
Fax: +86•755•377•9610

KOREA
Power Integrations
International
Holdings, Inc.
Rm# 402, Handuk Building,
649-4 Yeoksam-Dong,
Kangnam-Gu,
Seoul, Korea
Phone: +82•2•568•7520
Fax: +82•2•568•7474

JAPAN
Power Integrations, K.K.
Keihin-Tatemono 1st Bldg.
12-20 Shin-Yokohama 2-
Chome,
Kohoku-ku, Yokohama-shi,
Kanagawa 222, Japan
Phone: +81•45•471•1021
Fax: +81•45•471•3717

INDIA (Technical Support)
Innovatech
#1, 8th Main Road
Vasanthnagar
Bangalore, India 560052
Phone: +91•80•226•6023
Fax: +91•80•228•9727

APPLICATIONS HOTLINE
World Wide +1•408•414•9660

APPLICATIONS FAX
World Wide +1•408•414•9760

