



Design Example Report

Title	<i>High Performance, Low Profile 100 W PFC Stage Using HiperPFS™ PFS704EG</i>
Specification	90 VAC – 264 VAC Input; 380 VDC Output
Application	PFC Front End Stage
Author	Applications Engineering Department
Document Number	DER-272
Date	April 13, 2012
Revision	1.1

Summary and Features

- Low component count, high performance PFC
- EN61000-3-2 Class D compliance
- High PFC efficiency enables 80 Plus PC Main design
- Frequency sliding maintains high efficiency across load range
- Feed forward line sense gain - maintains relatively constant loop gain over entire operating voltage range
- Excellent transient load response
- Power Integration eSIP™ low-profile, low thermal resistance package
- Low profile, <15 mm above PCB

PATENT INFORMATION

The products and applications illustrated herein (including transformer construction and circuits external to the products) may be covered by one or more U.S. and foreign patents, or potentially by pending U.S. and foreign patent applications assigned to Power Integrations. A complete list of Power Integrations' patents may be found at www.powerint.com. Power Integrations grants its customers a license under certain patent rights as set forth at <http://www.powerint.com/ip.htm>.

Table of Contents

1	Introduction.....	4
2	Power Supply Specification	6
3	Schematic.....	7
4	Circuit Description	8
4.1	Input EMI Filter and Rectifier	8
4.2	PFS704EG Boost Converter	8
4.3	Bias Supply Regulator	8
4.4	Input Feed Forward Sense Circuit.....	8
4.5	Output Feedback.....	8
5	PCB Layout	10
6	Bill of Materials	11
7	Inductor Design Spreadsheet	13
8	Main Inductor Specifications.....	16
8.1	Electrical Diagram	16
8.2	Electrical Specifications.....	16
8.3	Materials.....	16
8.4	Winding Instructions	16
9	Common-mode Inductor Specifications.....	17
9.1	Electrical Diagram	17
9.2	Electrical Specifications.....	17
9.3	Materials.....	17
9.4	Winding Instructions	17
10	Heat Sink Specifications	18
10.1	Diode Bridge Heat Sink	18
10.1.1	Diode Bridge Heat Sink Drawing	18
10.1.2	Diode Bridge Heat Sink Fabrication Drawing	19
10.1.3	Diode Bridge Heat Sink Assembly Drawing	20
10.2	eSIP Heat Sink Assembly.....	21
10.2.1	eSIP Heat Sink Drawing.....	21
10.2.2	eSIP Heat Sink Fabrication Drawing	22
10.2.3	eSIP Heat Sink Assembly Drawing	23
11	Performance Data	24
11.1	Efficiency (w/ thermistor in-circuit, no forced air cooling).....	24
11.2	Input Power Factor	25
11.3	Regulation	26
11.3.1	Load	26
11.3.2	Line	27
11.4	Input Current Harmonic Distortion (IEC 61000-3-2 Class D).....	28
11.4.1	50% Load at Output	28
11.4.2	100% Load at Output	29
12	Thermal Performance	30
13	Waveforms.....	31
13.1	Input Current at 115 VAC and 60 Hz.....	31
13.2	Input Current at 230 VAC and 50 Hz.....	31
13.3	Start-up at 90 VAC and 60 Hz.....	32



13.4	Start-up at 115 VAC and 60 Hz	32
13.5	Start-up at 230 VAC and 50 Hz	33
13.6	Start-up at 264 VAC and 50 Hz	33
13.7	Load Transient Response (90 VAC / 60 Hz).....	34
13.8	Load Transient Response (115 VA / 60 Hz)	35
13.9	Load Transient Response (230 VAC / 50 Hz).....	35
13.10	Load Transient Response (264 VAC / 50 Hz)	36
13.11	1000 ms Line Dropout (115 VC / 60 Hz and 230 VAC / 50 Hz).....	36
13.11.1	50% Load at Output	36
13.11.2	Full Load at Output	37
13.12	One Cycle Line Dropout (115 VAC / 60 Hz and 230 VAC / 50 Hz)	37
13.12.1	Full Load at Output	37
13.13	Line Sag (115 VAC – 85 VAC – 115 VAC, 60 Hz)	38
13.14	Line Surge (132 VAC – 147 VAC – 132 VAC, 60 Hz)	38
13.15	Line Sag (230 VAC – 170 VAC – 230 VAC, 50 Hz)	39
13.16	Line Surge (264 VAC – 293 VAC – 264 VAC, 50 Hz)	39
13.17	Brown-In and Brown-Out at Full Load	40
13.18	Output Ripple Measurements	41
13.18.1	Ripple Measurement Technique	41
13.18.2	Measurement Results	42
14	Line Surge Test	44
15	EMI Scans at Full Load	45
16	Revision History	49

Important Note:

Although this board is designed to satisfy safety isolation requirements, the engineering prototype has not been agency approved. Therefore, all testing should be performed using an isolation transformer to provide the AC input to the prototype board.



1 Introduction

This document is an engineering report describing a PFC power supply utilizing a HiperPFS PFS704EG integrated PFC controller. This power supply is intended as a general purpose evaluation platform that operates from universal input and provides a regulated 380 VDC output voltage and a continuous output power of 100 W.

This power supply can deliver the rated power at 110 VAC or higher at a room temperature of 25 °C. For operation at higher temperatures or lower input voltages, use of forced air cooling is recommended.

The document contains the power supply specification, schematic, bill of materials, inductor documentation, printed circuit layout, and performance data.

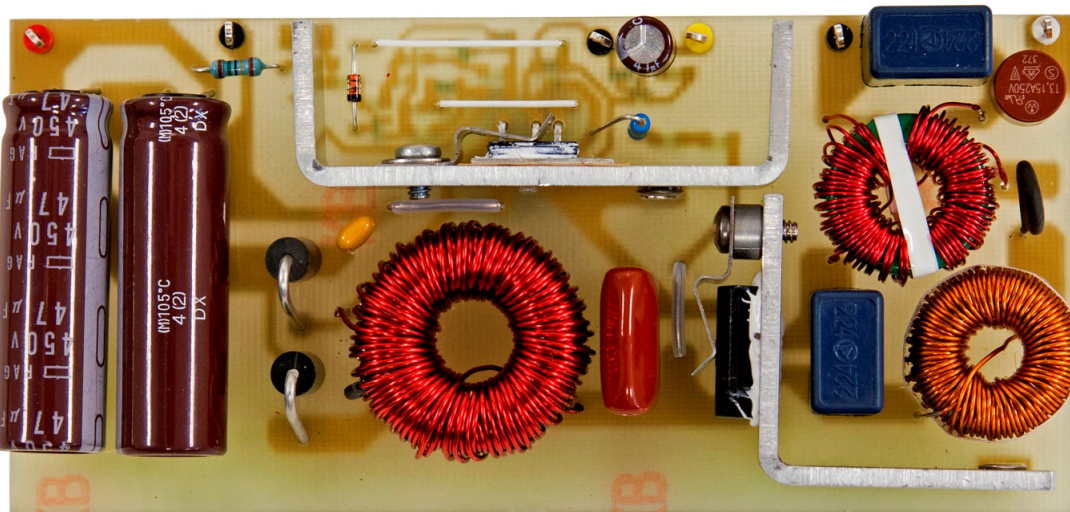

Figure 1 – Top Side of the Populated Circuit Board Photograph.



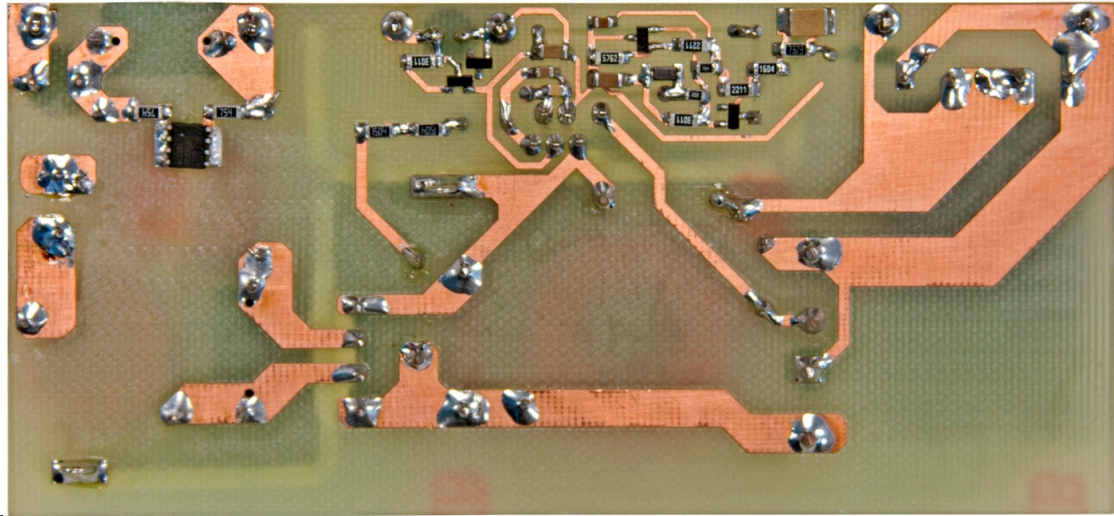

Figure 2 – Bottom Side of the Populated Circuit Board Photograph.

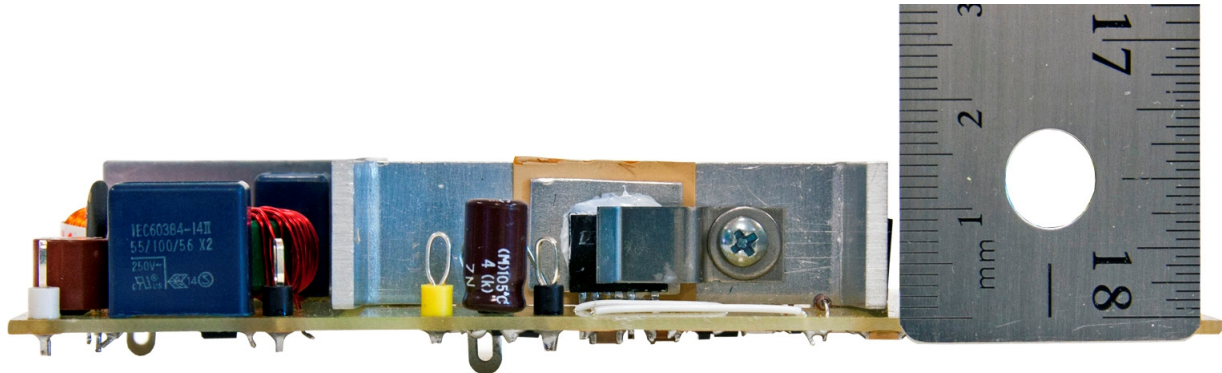

Figure 3 – Side of the Populated Circuit Board Photograph.



2 Power Supply Specification

The table below represents the minimum acceptable performance of the design. Actual performance is listed in the results section.

Description	Symbol	Min	Typ	Max	Units	Comment
Input						
Voltage	V_{IN}	90		264	VAC	3 Wire
Frequency	f_{LINE}	47	50/60	64	Hz	
Output						
Output Voltage	V_{OUT}	370	380	390	V	20 MHz bandwidth
Output Ripple Voltage p-p	V_{RIPPLE}			20	V	
Output Current	I_{OUT}		0.262		A	
Total Output Power						
Continuous Output Power	P_{OUT}		100		W	
Efficiency						
Full Load	η		94		%	Measured at P_{OUT} 25 °C
Minimum efficiency at 20, 50 and 100 % of P_{OUT}	η_{80+}		94		%	Measured at 115 VAC Input
Environmental						
Line Surge Differential Mode (L1-L2)			1		kV	1.2/50 μ s surge, IEC 1000-4-5, Series Impedance: Differential Mode: 2 Ω
Ambient Temperature	T_{AMB}	0		40	°C	Forced convection required at T_{AMB} >25 °C and/or V_{IN} <115 V, sea level
Auxiliary Supply Input						
Auxiliary Supply	V_{AUX}	15		24	V	DC Supply



3 Schematic

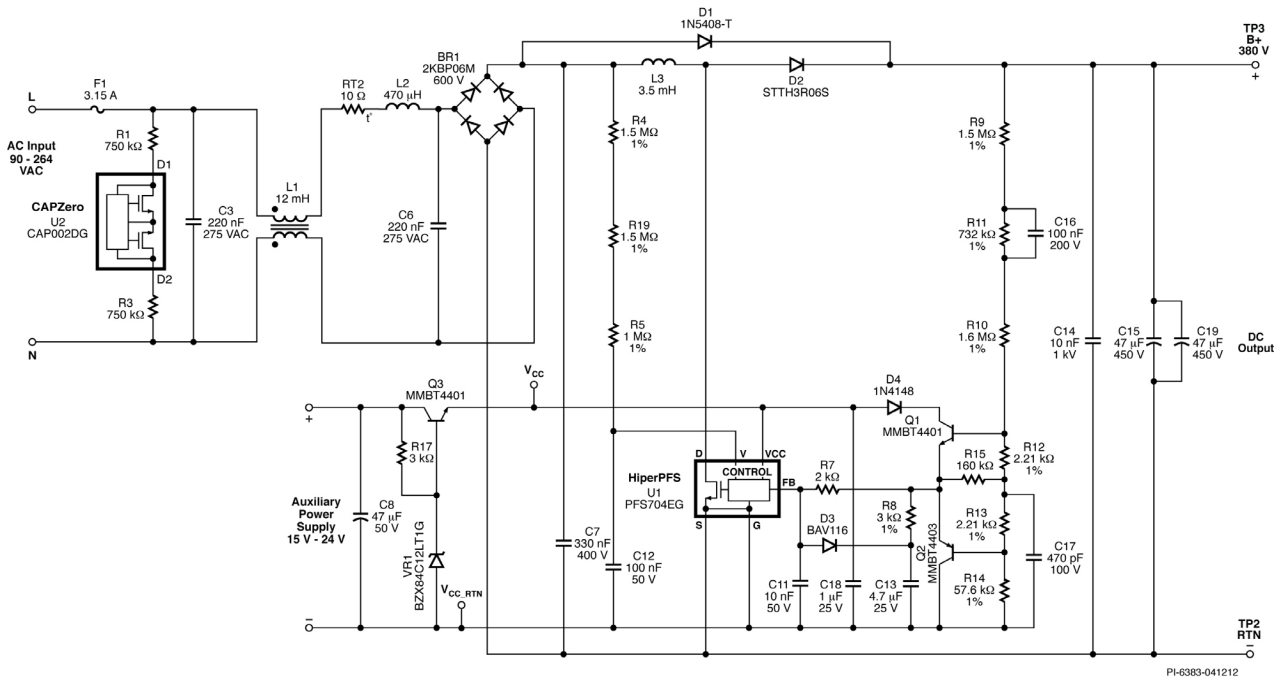

Figure 4 – Schematic.



4 Circuit Description

This PFC circuit is designed using PFS704EG Power Integrations integrated PFC controller. This design is rated for a continuous output power of 100 W and provides a regulated output voltage of 380 VDC nominal maintaining a high input power factor and overall efficiency from light load to full load.

4.1 Input EMI Filter and Rectifier

Fuse F1 provides protection to the circuit and isolates it from the AC supply in case of a fault. Diode Bridge BR1 rectifies the AC input. Capacitors C3, C6 and C7 together with inductors L1 and L2 form the EMI filter reducing the common mode and differential mode noise. Resistors R1, R3 and CAPZero, IC U2 are required to discharge the EMI filter capacitors once the AC is disconnected. The use of CAPZero IC U2 eliminates the static loss of R1 and R3, reducing standby and no-load input power. Thermistor RT2 limits the inrush current when AC is first applied.

4.2 PFS704EG Boost Converter

The boost converter stage consists of inductor L3, diode rectifier D2, filter capacitors C15 and C19 and the PFS704EG IC U1. This converter stage controls the input current of the power supply while simultaneously regulating the output DC voltage. Diode D1 prevents a resonant build-up of output voltage at start-up by bypassing inductor L5 (preventing saturation) while simultaneously charging output capacitors C15 and C19. Capacitor C14 is used for reducing the loop length and area of the output circuit to reduce EMI and overshoot of voltage across the drain and source of the power MOSFET inside U1 at each switching instant.

4.3 Bias Supply Regulator

The PFS704EG IC requires a regulated supply of 12 V for operation and the supply voltage must remain below 13.4 V to avoid IC damage. Resistor R17, Zener diode VR1, and transistor Q3 form a shunt regulator that prevents the supply voltage to IC U1 from exceeding 13 V. Capacitors C8 and C18 filter the supply voltage to ensure reliable operation of IC U1. The minimum value of C18 (including tolerance and temperature) should be $\geq 0.47 \mu\text{F}$ for correct IC operation, thus limiting VCC pin noise to $\leq 200 \text{ mV}$.

4.4 Input Feed Forward Sense Circuit

The input voltage of the power supply is sensed by the IC U1 using resistors R4, R5 and R19. The capacitor C12 filters any noise on this signal.

4.5 Output Feedback

Divider network comprising of resistors R9, R10, R11, R12, R13 and R14 are used to scale the output voltage and provide feedback to the IC U1. The circuit comprising of diode D4, transistor Q1, Q2 and the resistors R12 and R13 form a non-linear feedback circuit which help in improving the transient response by decreasing the response time of the PFC circuit to large output voltage changes.



Resistors R7, R8, R15 and capacitors C13 and C17 are required for shaping the loop response of the feedback circuit. The combination of resistor R8 and capacitor C13 provide a low frequency zero.

Diode D3 protects the circuit during a single fault condition in which capacitor C13 is accidentally shorted. If capacitor C13 is shorted, diode D3 ensures that the voltage at the FB pin of IC U1 is below the FB_{OFF} threshold preventing any switching of the MOSFET inside U1.



Want More?

Use your smartphone and free software from www.neoreader.com (or any other free QR Code Reader from your smartphone's App Store) and you will be connected to related content



5 PCB Layout

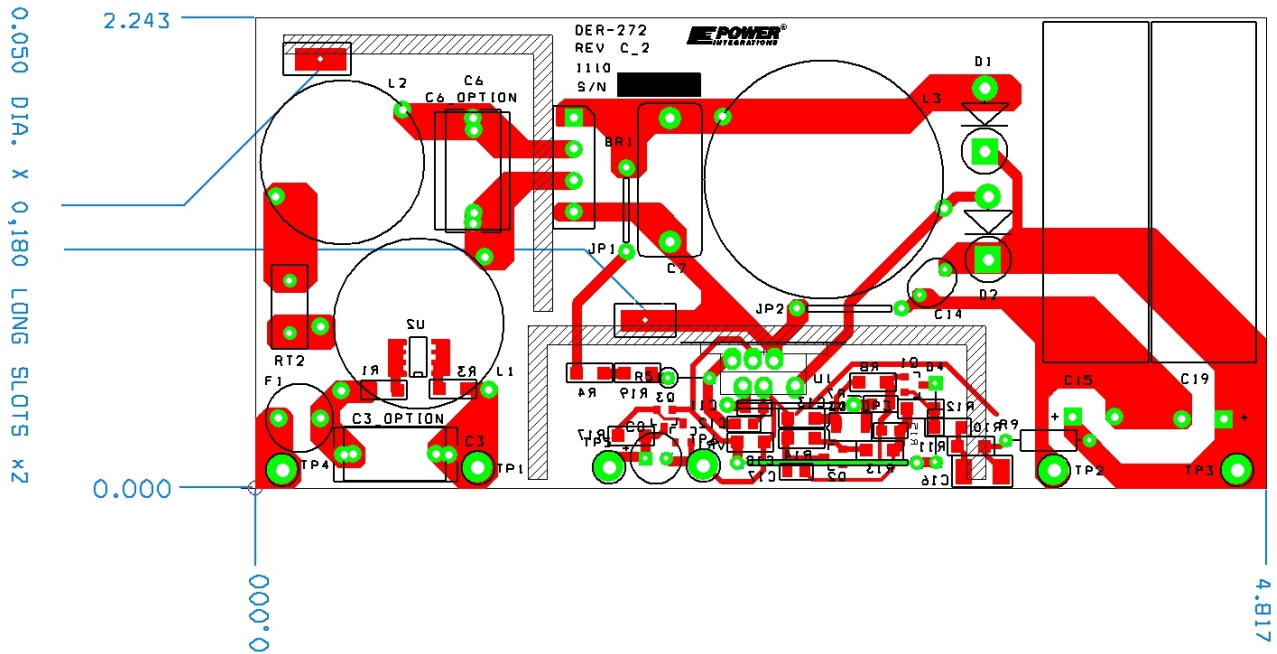

Figure 5 – Printed Circuit Layout, 4.81" (122.2 mm) x 2.24" (56.9 mm).



6 Bill of Materials

Item	Qty	Ref Des	Description	Mfg Part Number	Mfg
1	1	BR1	600 V, 2 A, Bridge Rectifier, Glass Passivated	2KBP06M-E4/51	Vishay
2	2	C3 C6	220 nF, 275 VAC, Film, X2	LE224-M	OKAYA ELECT
3	1	C7	330 nF, 400 V, Film	DME4P33K-F	Cornell Dubilier
4	1	C8	47 μ F, 50 V, Electrolytic, Gen. Purpose, (6.3 x 11)	EKMG500ELL470MF11D	Nippon Chemi-Con
5	1	C11	10 nF, 50 V, Ceramic, X7R, 0805	ECJ-2VB1H103K	Panasonic
6	1	C12	100 nF, 50 V, Ceramic, X7R, 0805	C2012X7R1H104K	TDK
7	1	C13	4.7 μ F, 25 V, Ceramic, X7R, 1206	ECJ-3YB1E475M	Panasonic
8	1	C14	10 nF, 1 kV, Disc Ceramic, X7R	SV01AC103KAR	AVX
9	2	C15 C19	47 μ F, 450 V, Electrolytic, Low ESR, (12.5 x 40)	EPAG451ELL470MK40S	Nippon Chemi-Con
10	1	C16	100 nF, 200 V, Ceramic, X7R, 1812	18122C104KAT2A	AVX
11	1	C17	470 pF, 100 V, Ceramic, X7R, 0805	08051C471KAT2A	AVX
12	1	C18	1 μ F, 25 V, Ceramic, X7R, 1206	C3216X7R1E105K	TDK
13	1	D1	1000 V, 3 A, Rectifier, DO-201AD	1N5408-T	Diodes, Inc.
14	1	D2	600 V, 3 A, SMC, DO-201AD	STTH3R06	ST Micro
15	1	D3	130 V, 5%, 250 mW, SOD-123	BAV116W-7-F	Diodes, Inc.
16	1	D4	75 V, 300 mA, Fast Switching, DO-35	1N4148TR	Vishay
17	2	ESIPCLIP M4 METAL1 ESIPCLIP M4 METAL2	Heat sink Hardware, Edge Clip, 20.76 mm L x 8 mm W x 0.015 mm Thk	NP975864	Aavid
18	1	F1	3.15 A, 250 V, Slow, TR5	37213150411	Wickman
19	2	GREASE1 GREASE2	Thermal Grease, Silicone, 5 oz Tube	CT40-5	ITW Chemtronics
20	1	HS- HIPERPFS- 100W- BRIDGE1	Heat sink, Bridge, Al 3003, 0.090 Thk		Custom
21	1	HS- HIPERPFS- 100W-ESIP2	Heat sink, eSIP, Al 3003, 0.090 Thk		Custom
22	1	HTSSPRDRR1	Heat Spreader, Al, 1100, 0.032 Thk x 0.630" (16 mm) L x 0.492" (12.5mm) W		Custom
23	1	JP1	Wire Jumper, Insulated, TFE, #22 AWG, 0.4"	C2004-12-02	Alpha
24	2	JP2 JP3	Wire Jumper, Insulated, TFE, #22 AWG, 0.3"	C2004-12-02	Alpha
25	1	L1	12 mH, Common Mode Choke		Custom
26	1	L2	470 μ H, 1.6 A, Vertical Toroidal	2120-V-RC	Bourns
27	1	L3	Custom, 100 W PFC Inductor, 3.5 mH		Custom
28	2	Q1 Q3	NPN, Small Signal BJT, GP SS, 40 V, 0.6 A, SOT-23	MMBT4401LT1G	Diodes, Inc.
29	1	Q2	PNP, Small Signal BJT, 40 V, 0.6 A, SOT-23	MMBT4403-7-F	Diodes, Inc.
30	2	R1 R3	750 k Ω , 5%, 1/4 W, Thick Film, 1206	ERJ-8GEYJ754V	Panasonic
31	2	R4 R19	1.50 M Ω , 1%, 1/4 W, Thick Film, 1206	ERJ-8ENF1504V	Panasonic
32	1	R5	1 M Ω , 1%, 1/4 W, Metal Film	MFR-25FBF-1M00	Yageo
33	1	R7	2 k Ω , 5%, 1/8 W, Thick Film, 0805	ERJ-6GEYJ202V	Panasonic
34	2	R8 R17	3.01 k Ω , 1%, 1/4 W, Thick Film, 1206	ERJ-8ENF3011V	Panasonic
35	1	R9	1.5 M Ω , 1%, 1/4 W, Metal Film	RNF14FTD1M50	Stackpole
36	1	R10	1.60 M Ω , 1%, 1/4 W, Thick Film, 1206	ERJ-8ENF1604V	Panasonic
37	1	R11	732 k Ω , 1%, 1/4 W, Thick Film, 1206	ERJ-8ENF7323V	Panasonic
38	2	R12 R13	2.21 k Ω , 1%, 1/4 W, Thick Film, 1206	ERJ-8ENF2211V	Panasonic



39	1	R14	57.6 k Ω , 1%, 1/4 W, Thick Film, 1206	ERJ-8ENF5762V	Panasonic
40	1	R15	160 k Ω , 5%, 1/8 W, Thick Film, 0805	ERJ-6GEYJ164V	Panasonic
41	1	RT2	NTC Thermistor, 10 Ω , 1.7 A	CL-120	Thermometrics
42	1	SCREW1	SCREW MACHINE PHIL 4-40 X 3/16 SS	67413609	MSC Industrial
43	1	SCREW2	SCREW MACHINE PHIL 4-40 X 5/16 SS	PMSSS 440 0031 PH	Building Fasteners
44	1	STANDOFF RND1	SPACER RND 0.140" DIA x 0.125" L, AL	3403	Keystone
45	2	TERMINAL EYELET1 TERMINAL EYELET2	Terminal, Eyelet, Tin Plated Brass	190	Zierick
46	1	TO-220 PAD1	Heat Pad TO-247 .006" K10	K10-104	Bergquist
47	3	TP1 TP2 TP6	Test Point, BLK, THRU-HOLE MOUNT	5011	Keystone
48	1	TP3	Test Point, RED, THRU-HOLE MOUNT	5010	Keystone
49	1	TP4	Test Point, WHT, THRU-HOLE MOUNT	5012	Keystone
50	1	TP5	Test Point, YEL, THRU-HOLE MOUNT	5014	Keystone
51	1	U1	HiperPFS, eSIP7/6-TH	PFS704EG	Power Integrations
52	1	U2	CAPZero, SO-8C	CAP002DG	Power Integrations
53	1	VR1	12 V, 5%, 225 mW, SOT23	BZX84C12LT1G	On Semi
54	2	WASHER1 WASHER2	WASHER FLAT #4 SS	FWSS 004	Building Fasteners



7 Inductor Design Spreadsheet

ACDC_PFS_101210; Rev.1.0; Copyright Power Integrations 2010	INPUT	INFO	OUTPUT	UNITS	ACDC_HiperPFS_101210_Rev1- 0.xls; Continuous Mode Boost Converter Design Spreadsheet
Enter Applications Variables					
Input Voltage Range	Universal		Universal		Select Universal or High_Line option
VACMIN			90	V	Minimum AC input voltage
VACMAX			265	V	Maximum AC input voltage
VBROWNIN			77.76		Expected Minimum Brown-in Voltage
VBROWNOUT			70.40	V	Specify brownout voltage.
VO	385			V	Nominal Output voltage
PO	100			W	Nominal Output power
fL			50	Hz	Line frequency
TA Max			40	deg C	Maximum ambient temperature
n			0.93		Enter the efficiency estimate for the boost converter at VACMIN
KP	0.600		0.6		Ripple to peak inductor current ratio at the peak of VACMIN
VO_MIN			365.75	V	Minimum Output voltage
VO_RIPPLE_MAX			20	V	Maximum Output voltage ripple
tHOLDUP			20	ms	Holdup time
VHOLDUP_MIN			310	V	Minimum Voltage Output can drop to during holdup
I_INRUSH			40	A	Maximum allowable inrush current
Forced Air Cooling	No		No		Enter "Yes" for Forced air cooling. Otherwise enter "No"
PFS Parameters					
PFS Part Number	Auto		PFS704		Selected PFS device
IOCP min			3.80	A	Minimum Current limit
IOCP typ			4.20	A	Typical current limit
IOCP max			4.60	A	Maximum current limit
RDSON			1.10	ohms	Typical RDson at 100 °C
RV			4.00	Mohms	Line sense resistor
C_VCC			1.00	uF	Supply decoupling capacitor
C_V			100.00	nF	V pin decoupling capacitor
C_FB			10.00	nF	Feedback pin decoupling capacitor
FS_PK			79.61	kHz	Estimated peak frequency of operation
FS_AVG			64.71	kHz	Estimated average frequency of operation
IP			2.41	A	MOSFET peak current
PFS_IRMS			1.15	A	PFS MOSFET RMS current
PCOND_LOSS_PFS			1.45	W	Estimated PFS conduction losses
PSW_LOSS_PFS			0.77	W	Estimated PFS switching losses
PFS_TOTAL			2.23	W	Total Estimated PFS losses
TJ Max			100	deg C	Maximum steady-state junction temperature
Rth-JS			3.00	degC/W	Maximum thermal resistance (Junction to heat sink)
HEATSINK Theta-CA			23.96	degC/W	Maximum thermal resistance of heat sink
Basic Inductor Calculation					
LPFC			665.10	uH	Value of PFC inductor at peak of VACMIN and Full Load
LPFC (0 Bias)			3471.18	uH	Value of PFC inductor at No load. This is the value measured with LCR meter
LPFC_RMS			1.36	A	Inductor RMS current (calculated at VACMIN and Full Load)
Inductor Construction Parameters					
Core Type	Sendust		Sendust		Enter "Sendust", "Pow Iron" or "Ferrite"
Core Material	125u		125u		Select from 60u, 75u, 90u or 125 u for Sendust cores. Fixed at PC44 or equivalent for Ferrite cores. Fixed at 52 material for Pow Iron cores.



Core Geometry	TOROID		TOROID		Select from Toroid or EE for Sendust cores and from EE, or PQ for Ferrite cores
Core	77350(OD=24.3)		77350(OD=24.3)		Core part number
AE			38.8	mm^2	Core cross sectional area
LE			58.8	mm	Core mean path length
AL			104	nH/t^2	Core AL value
VE			2280	mm^3	Core volume
HT			9.65	mm	Core height/Height of window
MLT			33.4	cm	Mean length per turn
BW			N/A	mm	Bobbin width
NL			183		Inductor turns
LG			N/A	mm	Gap length (Ferrite cores only)
ILRMS			1.36	A	Inductor RMS current
Wire type	Regular				Select between "Litz" or "Regular" for double coated magnet wire
AWG	23	<i>Info</i>	23	AWG	!!! Info. Selected wire gauge is too thick and may cause increased proximity losses. Selecta thinner wire gauge
Filar	1		1		Inductor wire number of parallel strands
OD			0.574	mm	Outer diameter of single strand of wire
AC Resistance Ratio			5.54		Ratio of AC resistance to the DC resistance (using Dowell curves)
J			5.27	A/mm^2	Estimated current density of wires. It is recommended that $4 < J < 6$
BM_TARGET			N/A	Gauss	Target flux density at VACMIN (Ferrite cores only)
BM			2580	Gauss	Maximum operating flux density
BP			5323	Gauss	Peak Flux density (Estimated at VBROWNOUT)
LPFC_CORE_LOSS			0.96	W	Estimated Inductor core Loss
LPFC_COPPER_LOSS			1.88	W	Estimated Inductor copper losses
LPFC_TOTAL_LOSS			2.84	W	Total estimated Inductor Losses
Critical Parameters					
IRMS			1.19	A	AC input RMS current
IO_AVG			0.26	A	Output average current
Output Diode					
Part Number	Auto		STTH2R06		PFC Diode Part Number
Type			ULTRAFast		Diode Type - Special - Diodes specially catered for PFC applications, SiC - Silicon Carbide type, UF - Ultrafast recovery type
Manufacturer			ST		Diode Manufacturer
VRRM			600	V	Diode rated reverse voltage
IF			2	A	Diode rated forward current
TRR			75	ns	Diode Reverse recovery time
VF			1.1	V	Diode rated forward voltage drop
PCOND_DIODE			0.29	W	Estimated Diode conduction losses
PSW_DIODE			1.39	W	Estimated Diode switching losses
P_DIODE			1.67	W	Total estimated Diode losses
TJ Max			125	deg C	Maximum Operating temperature
Rth-JS			35.00	degC/W	Maximum thermal resistance (Junction to heat sink)
HEATSINK Theta-CA			15.34	degC/W	Maximum thermal resistance of heat sink
Output Capacitor					
CO	Auto		100.00	uF	Minimum value of Output capacitance
VO_RIPPLE_EXPECTED			8.9	V	Expected ripple voltage on Output with selected Output capacitor
T_HOLDUP_EXPECTED			23.6	ms	Expected holdup time with selected Output capacitor
ESR_LF			1.66	ohms	
ESR_HF			0.663	ohms	
IC_RMS_LF			0.18	A	Low Frequency Capacitor RMS current
IC_RMS_HF			0.53	A	High Frequency Capacitor RMS current
CO_LF_LOSS			0.06	W	Estimated Low Frequency ESR loss in

CO_HF_LOSS			0.18	W	Output capacitor Estimated High frequency ESR loss in Output capacitor
Total CO LOSS			0.24	W	Total estimated losses in Output Capacitor
Input Bridge and Fuse					
I ² t Rating			7.02	A ² s	Minimum I ² t rating for fuse
Fuse Current rating			1.82	A	Minimum Current rating of fuse
VF			0.90	V	Input bridge Diode forward Diode drop
I _{AVG}			1.13	A	Input average current at 70 VAC.
PIV_INPUT BRIDGE			375	V	Peak inverse voltage of input bridge
PCOND_LOSS_BRIDGE			1.94	W	Estimated Bridge Diode conduction loss
CIN			0.33	uF	Input capacitor. Use metallized polypropylene or film foil type with high ripple current rating
RT			8.84	ohms	Input Thermistor value
D_Precharge			1N5407		Recommended precharge Diode
Feedback Components					
R2			1.54	Mohms	Feedback network, first high voltage divider resistor
R3			1.54	Mohms	Feedback network, second high voltage divider resistor
R4			698.00	kohms	Feedback network, third high voltage divider resistor
C2			100.00	nF	Feedback network, loop speedup capacitor
R5			2.20	kohms	Feedback component, NPN transistor bias resistor
R6			2.20	kohms	Feedback component, PNP transistor bias resistor
R7			57.60	kohms	Feedback network, lower divider resistor
C3			470.00	pF	Feedback component- noise suppression capacitor
R8			160.00	kohms	Feedback network - pole setting resistor
R9			2.94	kohms	Feedback network - zero setting resistor
R10			10.00	kohms	Feedback pin filter resistor
C4			10.00	uF	Feedback network - compensation capacitor
D3			1N4148		Feedback network reverse blocking Diode
D4			1N4001		Feedback network - capacitor failure detection Diode
Q1			2N4401		Feedback network - speedup circuit NPN transistor
Q2			2N4403		Feedback network - speedup circuit PNP transistor
Loss Budget (Estimated at VACMIN)					
PFS Losses			2.23	W	Total estimated losses in PFS
Boost diode Losses			1.67	W	Total estimated losses in Output Diode
Input Bridge losses			1.94	W	Total estimated losses in input bridge module
Inductor losses			2.84	W	Total estimated losses in PFC choke
Output Capacitor Loss			0.24	W	Total estimated losses in Output capacitor
Total losses			8.91	W	Overall loss estimate
Efficiency			0.92		Estimated efficiency at VACMIN. Verify efficiency at other line voltages



8 Main Inductor Specifications

8.1 Electrical Diagram

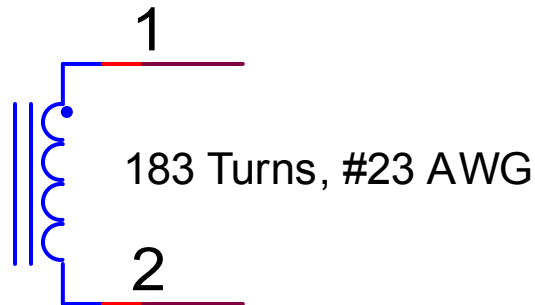

Figure 6 – Main Inductor Electrical Diagram.

8.2 Electrical Specifications

Primary Inductance	Pins 1-2 measured at 10 kHz, 0.4 V RMS	3.5 mH, $\pm 8\%$
---------------------------	--	-------------------

8.3 Materials

Item	Description
[1]	Core: Magnetics Inc, Mfg: 77350-A7
[2]	Single strange wire: #23 AWG

8.4 Winding Instructions

1. Wind turns in one direction to fill up the surface of layer #1 (65 ~ 68 turns).
2. Continue winding to fill up layer #2 (58 ~ 62 turns).
3. Continue winding on layer #3 for the remaining turns.

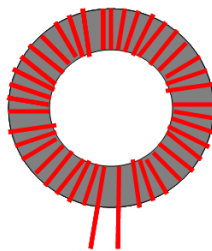

9 Common-mode Inductor Specifications

9.1 Electrical Diagram

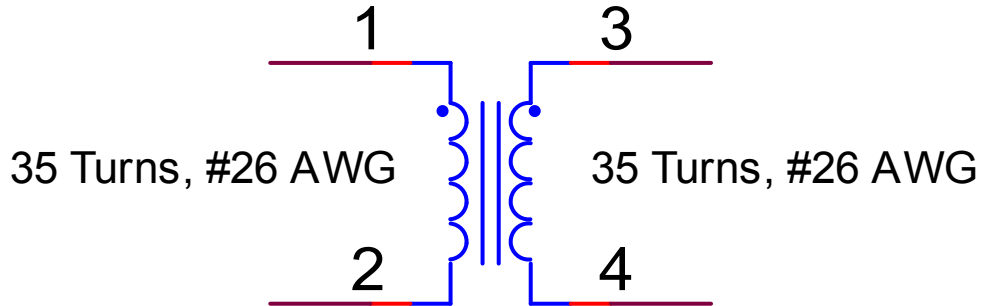

Figure 7 – Common-Mode Inductor Electrical Diagram.

9.2 Electrical Specifications

Primary Inductance	Pins 1-2, 3-4 measured at 10 kHz	12 mH, $\pm 25\%$
---------------------------	----------------------------------	-------------------

9.3 Materials

Item	Description
[1]	Core Type: TS10 TDG. (Zhejiang Tiantong, China) Mfg P/N: T18x10x8 TS10* Gap: $A_L = 9400 \text{ nH/N}^2$
[2]	Magnet Wire: #26 AWG
[3]	Number of Turns: 35 each section

*T18x10x8 is the physical size, TS10 is the core type

9.4 Winding Instructions

1. Insert a divider (tape or plastic wrap) in the core to divide into 2 sections equally.
2. Start winding on one section with 28 turns or completely fill up the section for the 1st layer, then equally spread the remaining turns for the 2nd layer.
3. Repeat step 2 for the other section winding. Make sure it starts from the SAME side and winding direction as step 2. See picture below.

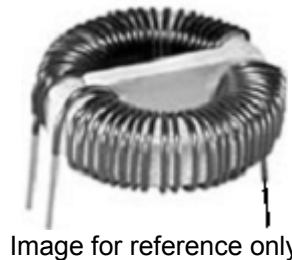
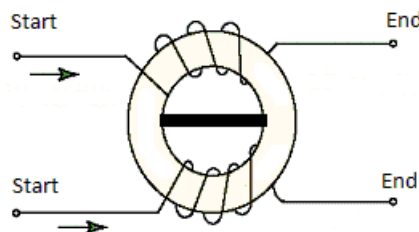

10 Heat Sink Specifications

10.1 Diode Bridge Heat Sink

10.1.1 Diode Bridge Heat Sink Drawing

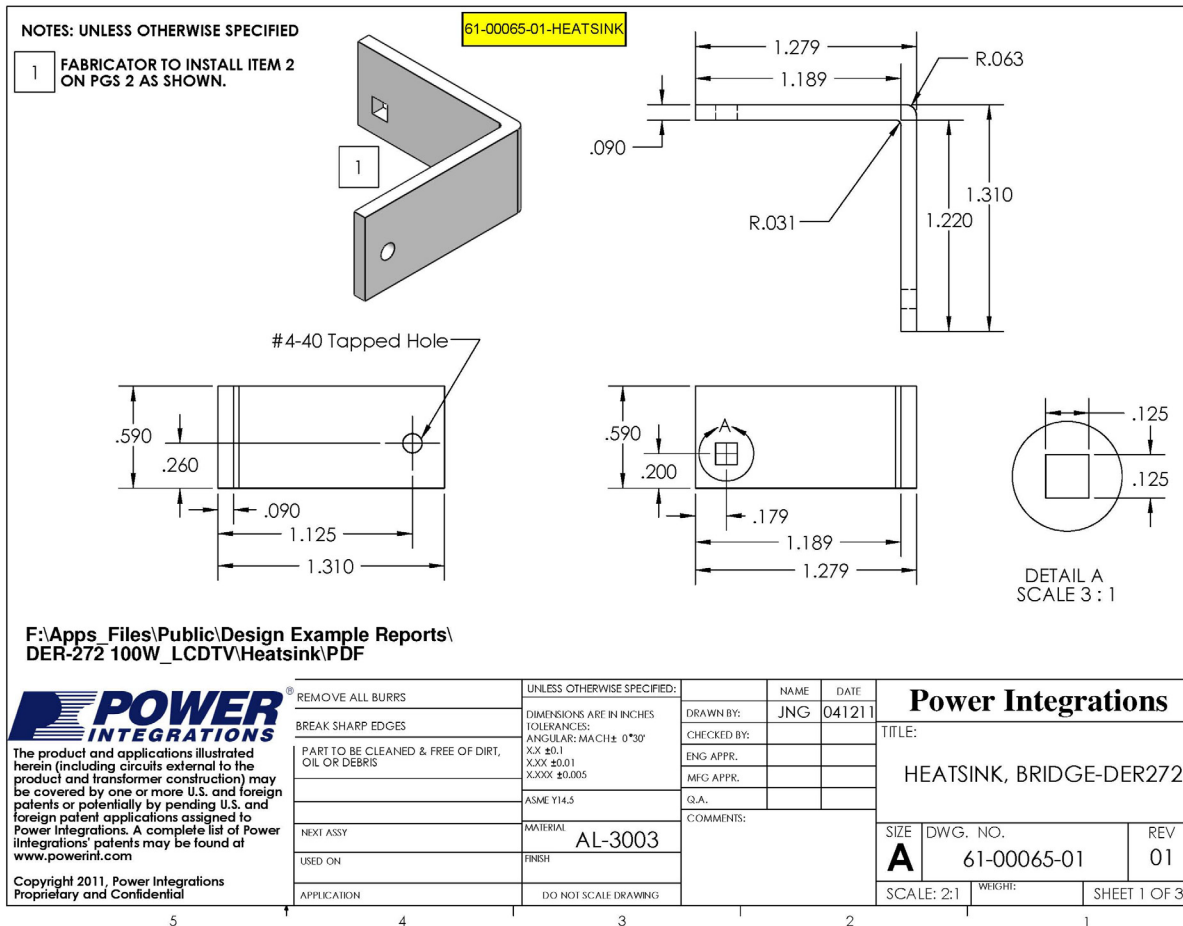

10.1.2 Diode Bridge Heat Sink Fabrication Drawing

NOTES: UNLESS OTHERWISE SPECIFIED

1 FABRICATOR TO INSTALL ITEM 2 AS SHOWN.

61-00065-01-HEATSINK

F:\Apps_Files\Public\Design Example Reports\DER-272 100W_LCDTV\Heatsink\PDF

ITEM NO.	PART NUMBER	DESCRIPTION	QTY.
1	61-00065-01	HEATSINK, BRIDGE, AL 3003, 0.090 THK CUSTOM	1
2	60-00016-00	TERMINAL, EYELET, ZIERICK PN 190	1

REMOVE ALL BURRS	UNLESS OTHERWISE SPECIFIED:	NAME	DATE	Power Integrations TITLE: HEATSINK, FAB, PI CUSTOM, DER272-ZIERCI, L-SHAPED W/MTG, BRKTS SIZE A DWG. NO. 61-00065-01 REV 01 SCALE: 2:1 WEIGHT: SHEET 2 OF 3
BREAK SHARP EDGES	DIMENSIONS ARE IN INCHES TOLERANCES: ANGULAR: MACH± 0°30'	DRAWN BY: JNG	041211	
PART TO BE CLEANED & FREE OF DIRT, OIL OR DEBRIS	XX ±0.1 XXX ±0.01 XXXX ±0.005	CHECKED BY:		
	ASME Y14.5	ENG APPR.		
NEXT ASSY	MATERIAL	MFG APPR.		
USED ON	FINISH	Q.A.		
APPLICATION	DO NOT SCALE DRAWING	COMMENTS:		

5 4 3 2 1



10.1.3 Diode Bridge Heat Sink Assembly Drawing

NOTES: UNLESS OTHERWISE SPECIFIED

61-00065-01-HEATSINK

ITEM NO.	PART NUMBER	DESCRIPTION	QTY.
1	61-00065-01	HEATSINK, BRIDGE, AL 3003, 0.090 THK CUSTOM	1
2	60-00016-00	TERMINAL, EYELET, ZIERICK PN 190	1
3	15-00703-00	600 V, 2 A, BRIDGE RECTIFIER, G. P	1
4	60-00042-00	EDGE CLIP, 20.76mm L x 8 mm WX 0.015mm THK	1
5	75-00002-00	SCREW MACHINE PHIL 4-40 X 5/16 SS	1
6	75-00032-00	WASHER FLAT #4 SS	1
7	60-00035-00	THERMAL GREASE, SILICONE, 5 OZ TUBE	1
8	76-00015-00	SPACER RND 0.140" DIA x .125" L, Aluminum	1

F:\Apps_Files\Public\Design Example Reports\DER-272 100W_LCDTV\Heatsink\PDF

<p>POWER INTEGRATIONS</p> <p>The product and applications illustrated herein (including circuits external to the product and transformer construction) may be covered by one or more U.S. and foreign patents or potentially by pending U.S. and foreign patent applications assigned to Power Integrations. A complete list of Power Integrations' patents may be found at www.powerint.com</p> <p>Copyright 2011, Power Integrations Proprietary and Confidential</p>	REMOVE ALL BURRS	UNLESS OTHERWISE SPECIFIED:	NAME	DATE	<p>Power Integrations</p> <p>TITLE:</p> <p>HEATSINK, ASSY, DER272 BRIDGE L-SHAPED W/MTG BRKTS</p> <p>SIZE DWG. NO. REV</p> <p>A 61-00065-01 01</p> <p>SCALE: 1:1 WEIGHT: SHEET 3 OF 3</p>	
	BREAK SHARP EDGES	DIMENSIONS ARE IN INCHES	DRAWN BY:	JNG		041211
	PART TO BE CLEANED & FREE OF DIRT, OIL OR DEBRIS	TOLERANCES:	CHECKED BY:			
		ANGULAR: MACH ± 0°30'	ENG APPR.			
		XX ±0.1	MFG APPR.			
		XXX ±0.01	Q.A.			
		XXXX ±0.005	COMMENTS:			
		ASME Y14.5				
NEXT ASSY	MATERIAL					
USED ON	FINISH					
APPLICATION	DO NOT SCALE DRAWING					

10.2 eSIP Heat Sink Assembly

10.2.1 eSIP Heat Sink Drawing

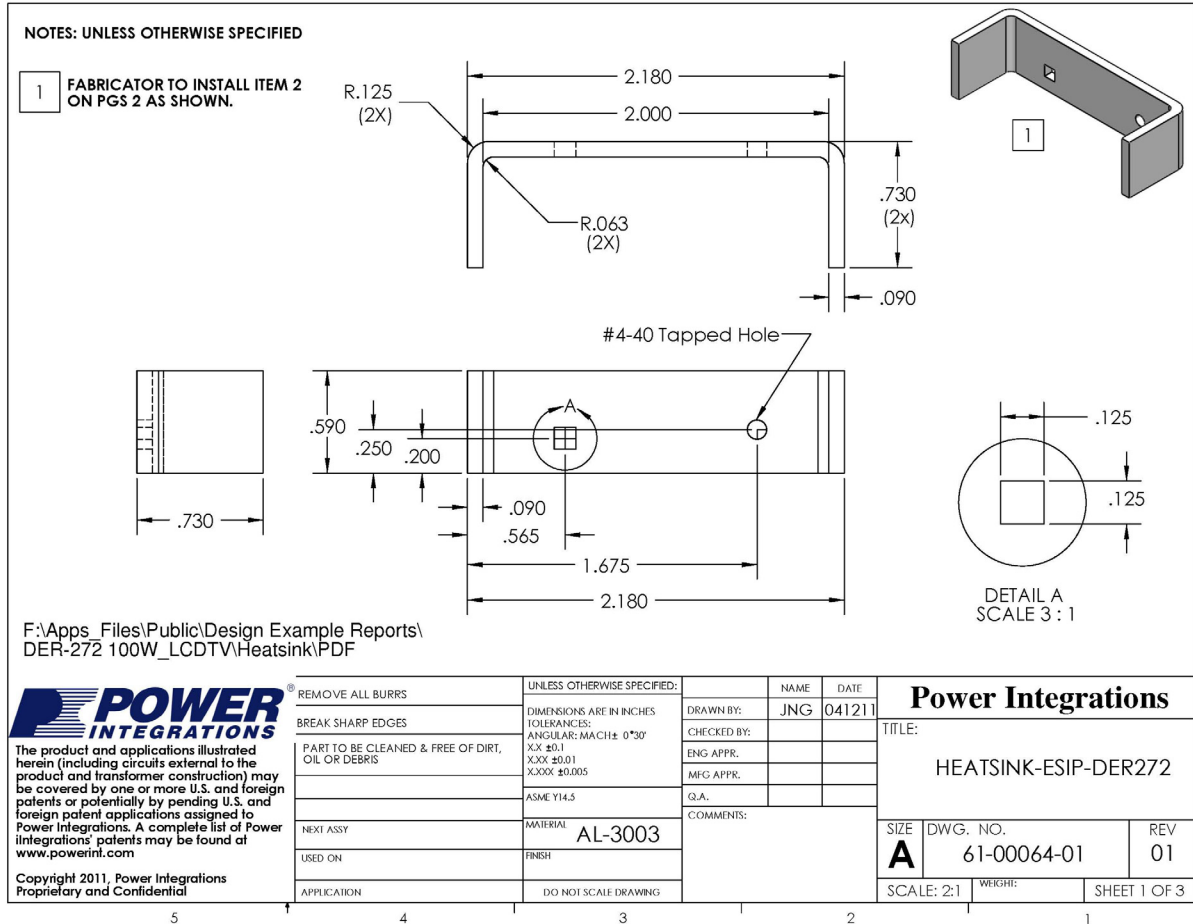

10.2.2 eSIP Heat Sink Fabrication Drawing

NOTES: UNLESS OTHERWISE SPECIFIED

1 FABRICATOR TO INSTALL ITEM 2 AS SHOWN.

F:\Apps_Files\Public\Design Example Reports\DER-272 100W_LCDTV\Heatsink\PDF

ITEM NO.	PART NUMBER	DESCRIPTION	QTY.
1	61-00064-01	HEATSINK, eSIP, AL 3003, 0.090 Thk	1
2	60-00016-00	TERMINAL, EYELET, ZIERICK PN 190	1

REMOVE ALL BURRS	UNLESS OTHERWISE SPECIFIED:	NAME	DATE	Power Integrations TITLE: HEATSINK, FAB, PI CUSTOM, DER272-ZIERICK, U SHAPED W/MTG, BRKTS SIZE DWG. NO. REV A 61-00064-01 01 SCALE: 1:1 WEIGHT: SHEET 2 OF 3
BREAK SHARP EDGES	DIMENSIONS ARE IN INCHES	DRAWN BY: JNG	041211	
PART TO BE CLEANED & FREE OF DIRT, OIL OR DEBRIS	TOLERANCES: ANGULAR: MACH ± 0°30' XX ±0.1 XXX ±0.01 XXXX ±0.005	CHECKED BY:		
	ASME Y14.5	ENG APPR.		
NEXT ASSY	MATERIAL	MFG APPR.		
USED ON	FINISH	Q.A.		
APPLICATION	DO NOT SCALE DRAWING	COMMENTS:		

5 4 3 2 1

10.2.3 eSIP Heat Sink Assembly Drawing

**NOTES: UNLESS OTHERWISE SPECIFIED
TRIM ITEM #7 .750" LONG (BER20-ND)**

ITEM NO.	PART NUMBER	DESCRIPTION	QTY.
1	61-00064-01	HEATSINK, eSIP, AL 3003, 0.090 THK	1
2	10-00313-00	HiperPFS, PFS704EG, eSIP7/6-TH	1
3	60-00042-00	EDGE CLIP, 20.76mm L x 8 mm WX 0.015mm THK	1
4	75-00089-00	SCREW MACHINE PHIL 4-40 X 3/16 SS	1
5	75-00032-00	WASHER FLAT #4 SS	1
6	61-00066-00	HEATSPREADER, AL, 1100, 0.032 THK x 16.0mm x 12.5mm	1
7	66-00083-00	HEATPAD TO-247 .006" K10	1
8	60-00016-00	TERMINAL, EYELET, ZIFERICK PN 190	1
9	66-00035-00	THERMAL GREASE SILICONE, 5OZ TUBE	1

F:\Apps_Files\Public\Design Example Reports\DER-272 100W_LCDTV\Heatsink\PDF

<p>POWER INTEGRATIONS</p> <p>The product and applications illustrated herein (including circuits external to the product and transformer construction) may be covered by one or more U.S. and foreign patents or potentially by pending U.S. and foreign patent applications assigned to Power Integrations. A complete list of Power Integrations' patents may be found at www.powerint.com</p> <p>Copyright 2011, Power Integrations Proprietary and Confidential</p>	REMOVE ALL BURRS	UNLESS OTHERWISE SPECIFIED:	NAME	DATE	<p>Power Integrations</p> <p>TITLE:</p> <p>HEATSINK, ASSY, DER272 ESIP U SHAPED W/MTG BRKTS</p> <p>SIZE DWG. NO. REV</p> <p>A 61-00064-01 01</p> <p>SCALE: 1:1 WEIGHT: SHEET 3 OF 3</p>	
	BREAK SHARP EDGES	DIMENSIONS ARE IN INCHES	DRAWN BY:	JNG		041211
	PART TO BE CLEANED & FREE OF DIRT, OIL OR DEBRIS	TOLERANCES:	CHECKED BY:			
		ANGULAR: MACH ± 0°30'	ENG APPR.			
		XX ±0.1 XXX ±0.01 XXXX ±0.005	MFG APPR.			
	ASME Y14.5	Q.A.				
NEXT ASSY	MATERIAL	COMMENTS:				
USED ON	FINISH					
APPLICATION	DO NOT SCALE DRAWING					



11 Performance Data

All measurements performed at room temperature, 60 Hz input frequency for voltages below 150 VAC and input frequency of 50 Hz for 150 VAC and higher.

11.1 Efficiency (w/ thermistor in-circuit, no forced air cooling)

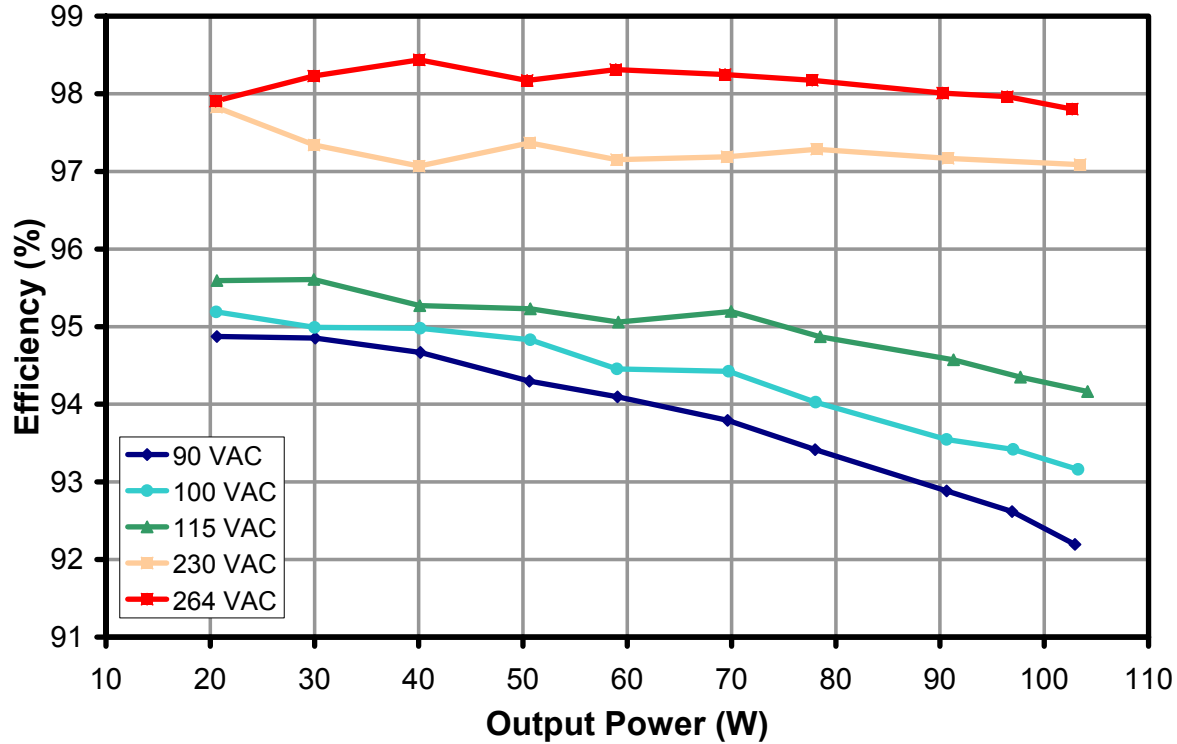

Figure 8 – Efficiency vs. Output Power.

11.2 Input Power Factor

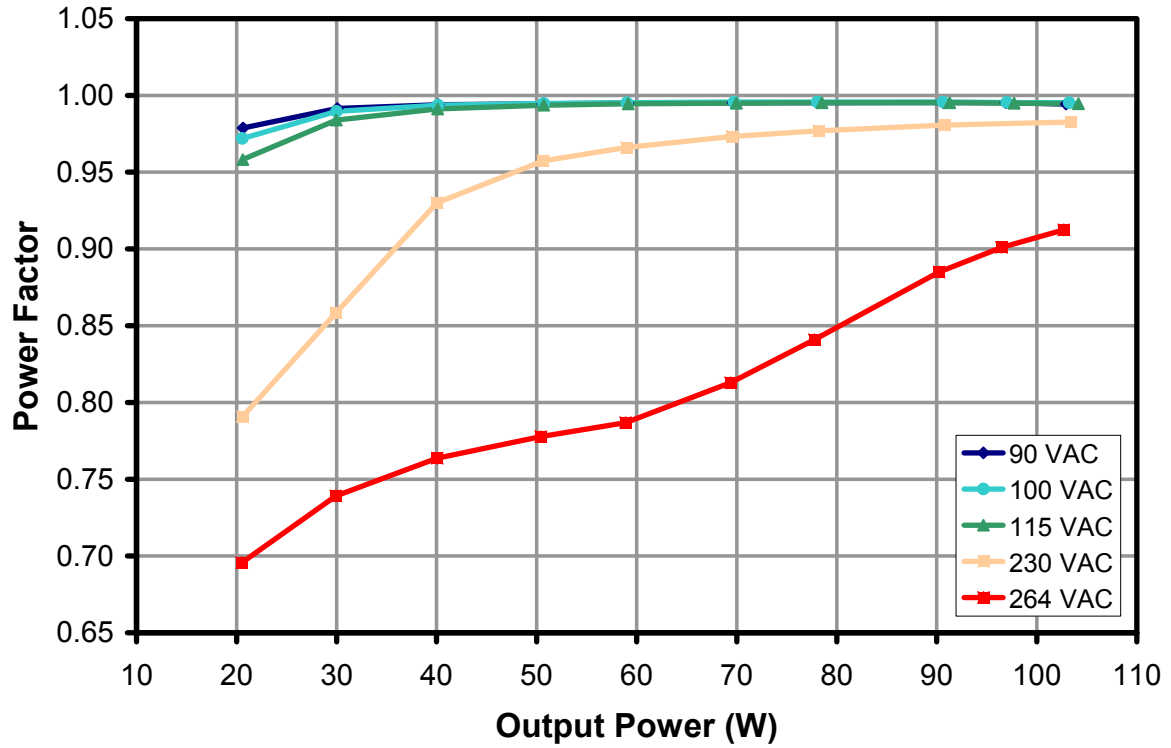

Figure 9 – Input Power Factor vs. Output Power.



11.3 Regulation

11.3.1 Load

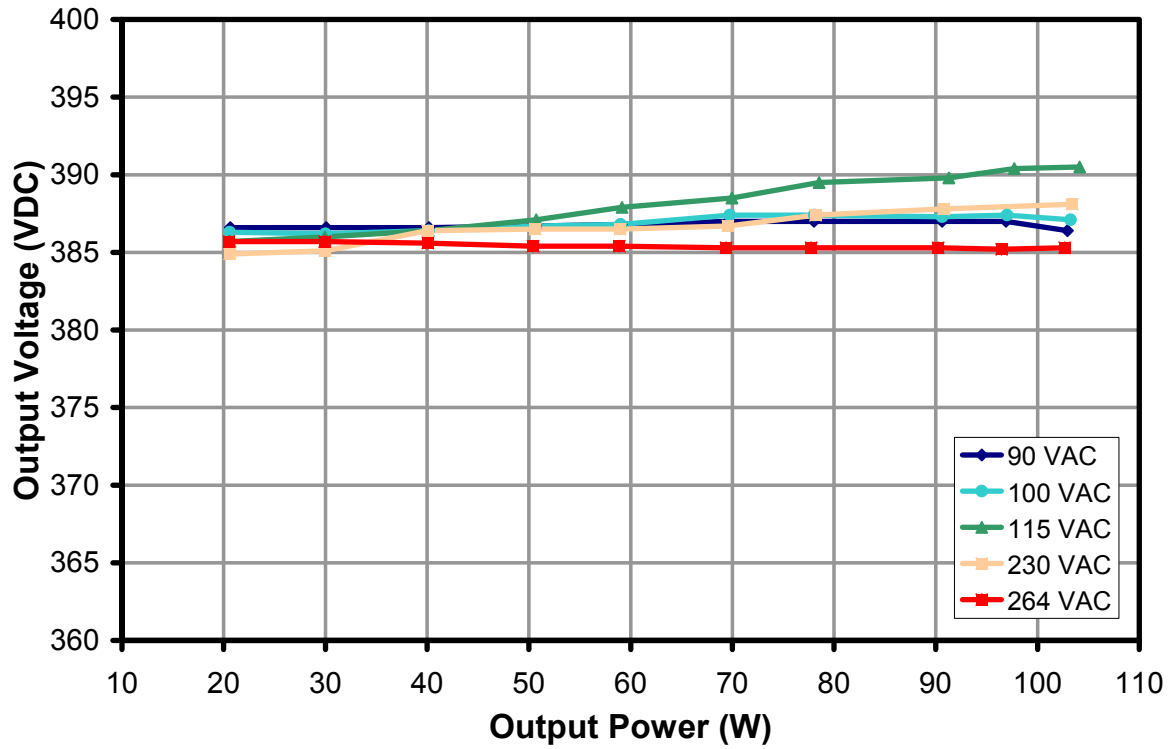

Figure 10 – Load Regulation.



11.3.2 Line

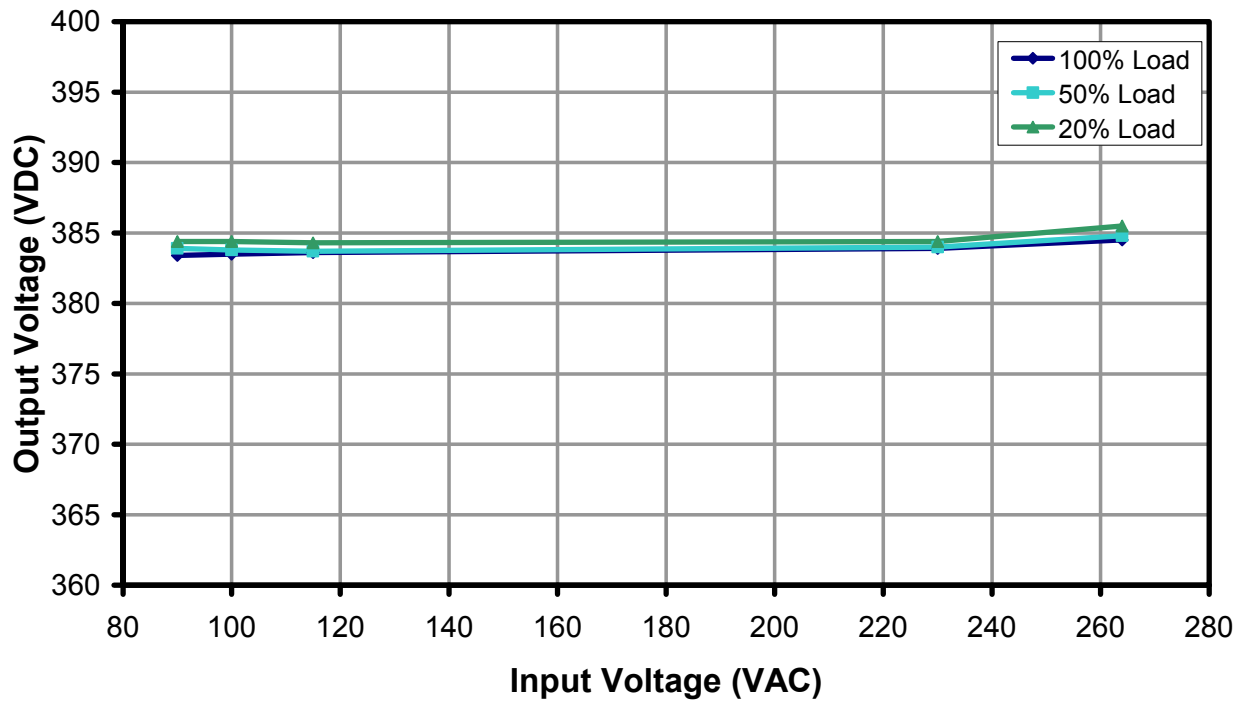

Figure 11 – Line Regulation.



11.4 Input Current Harmonic Distortion (IEC 61000-3-2 Class D)

Measured at 230 VAC Input 50 Hz

11.4.1 50% Load at Output

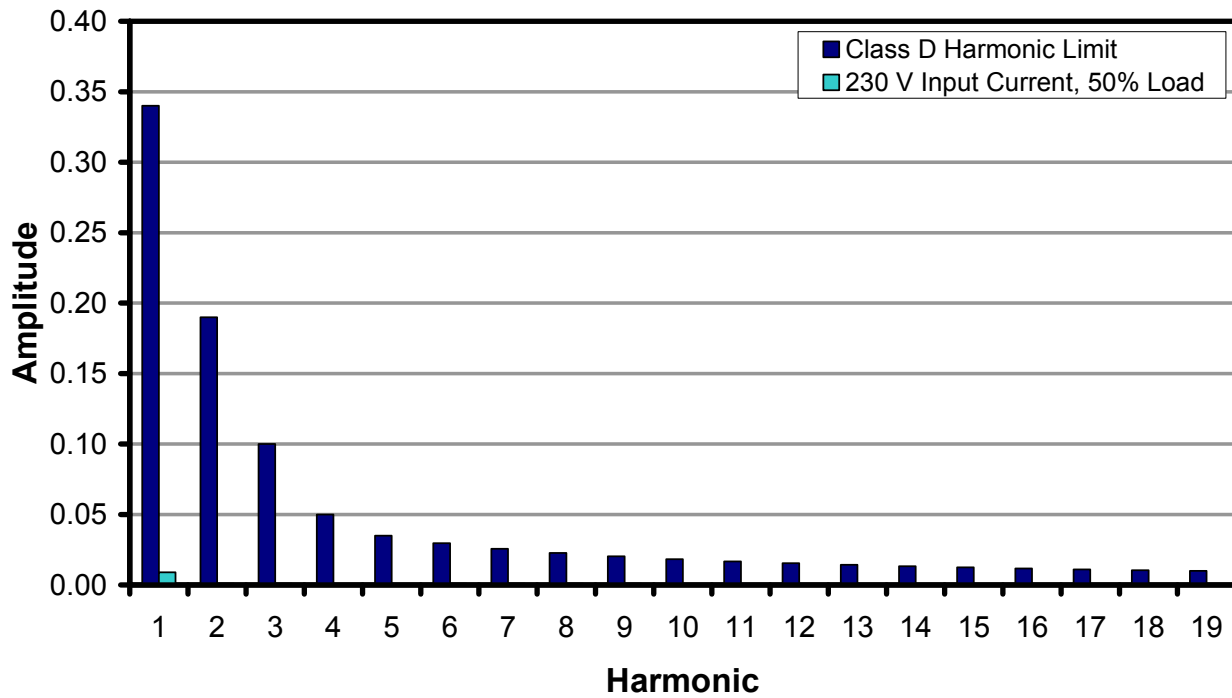

Figure 12 – Amplitude of Input Current Harmonics for 50% Load at 230 VAC Input.



11.4.2 100% Load at Output

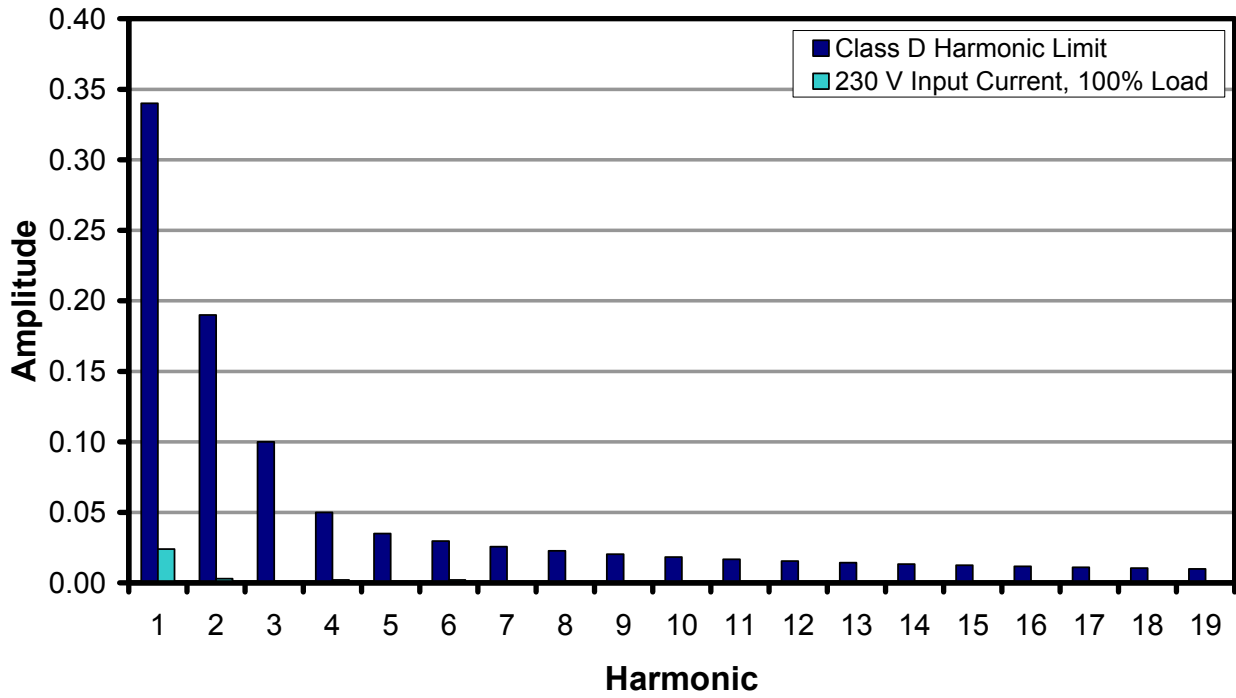

Figure 13 – Amplitude of Input Current Harmonics for 100% Load at 230 VAC Input.



12 Thermal Performance

The unit was allowed to reach thermal equilibrium prior to the measurement. Table 1 shows full load temperature of key components at equilibrium, room temperature and without any forced air cooling.

Component	Temperature (°C)
CM Inductor, L1	58.4
Differential Inductor, L2	63
Bridge Rectifier, BR1	82
Bridge Rectifier Capacitor, C7	58.5
Boost Inductor, L3	72
Output Diode	66
Output Capacitor	39.2
PFS704, U1	88.8
Ambient	44

Table 1 – Thermal Performance of Key Components at Full Load, 115 VAC.

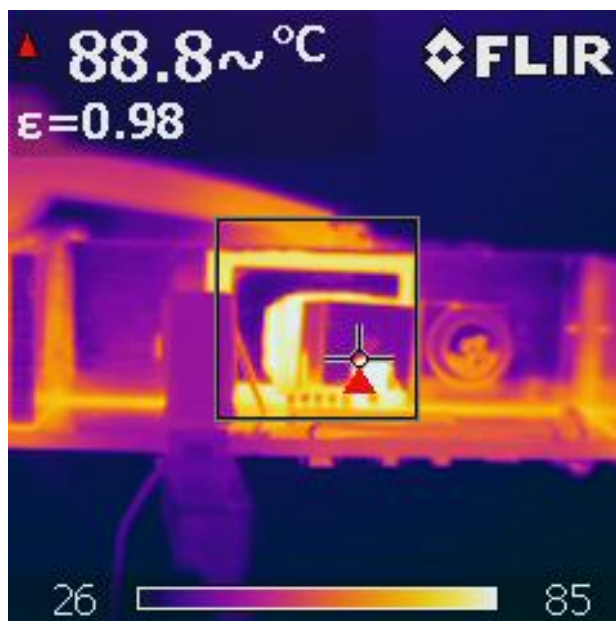

Figure 14 – Infrared Image of U1 IC, PFS704EG and Side of the Board at Thermal Equilibrium. 115 VAC, Full Load, No Forced-Air Flow, 44°C Ambient.



13 Waveforms

13.1 Input Current at 115 VAC and 60 Hz

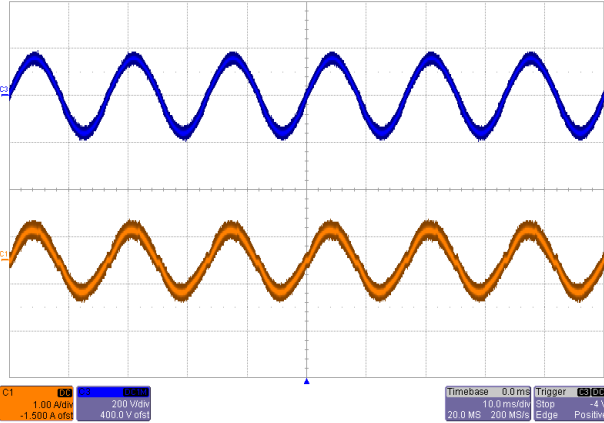

Figure 15 – 115 VAC, 50% Load.
 Top: V_{IN} , 200 V / div.
 Bottom: I_{IN} , 1 A, 10 ms / div.

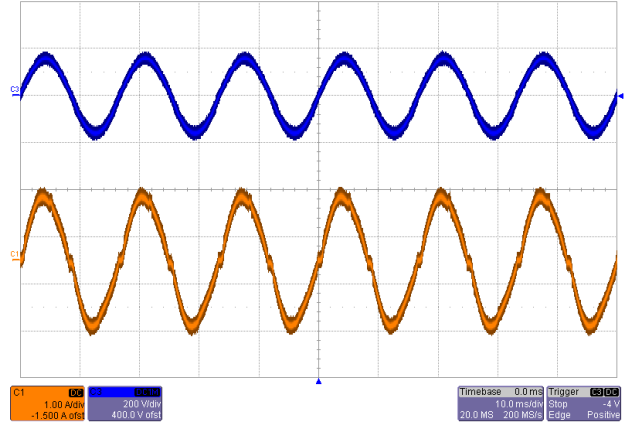

Figure 16 – 115 VAC, 100% Load.
 Top: V_{IN} , 200 V / div.
 Bottom: I_{IN} , 1 A, 10 ms / div.

13.2 Input Current at 230 VAC and 50 Hz

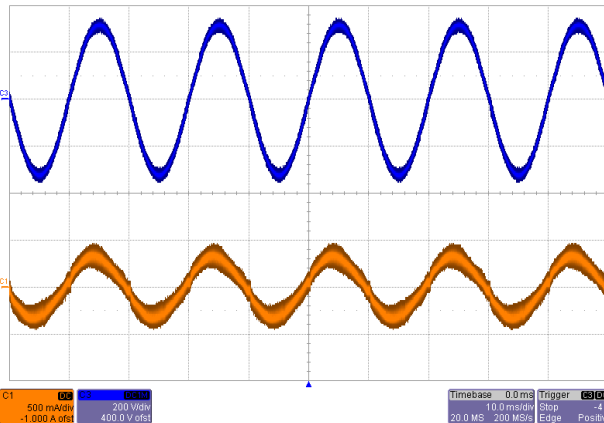

Figure 17 – 230 VAC, 50% Load.
 Top: V_{IN} , 200 V / div.
 Bottom: I_{IN} , 500 mA, 10 ms / div.

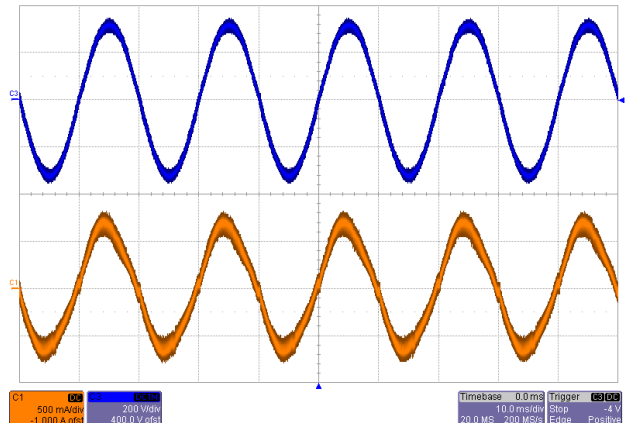

Figure 18 – 230 VAC, 100% Load.
 Top: V_{IN} , 200 V / div.
 Bottom: I_{IN} , 500 mA, 10 ms / div.



13.3 Start-up at 90 VAC and 60 Hz

Load in CC mode during turn-on of PFC.

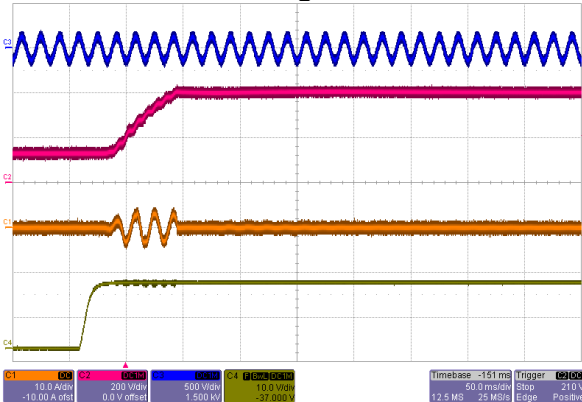

Figure 19 – 90 VAC, No Load.
 Top: V_{IN} , 500 V / div.
 Second: V_{OUT} , 200 V / div.
 Third: I_{IN} , 10 A / div.
 Bottom: V_{CC} , 10 V / div., 50 ms / div.

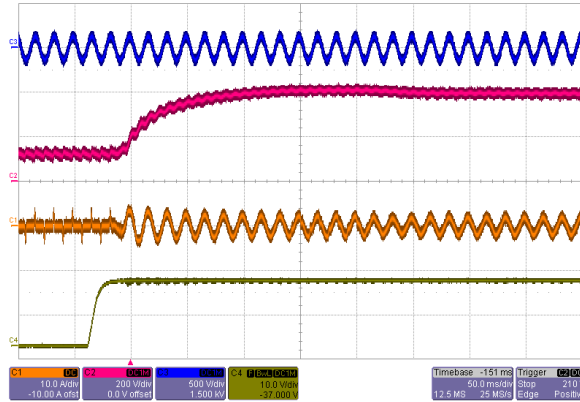

Figure 20 – 90 VAC, Full Load.
 Top: V_{IN} , 500 V / div.
 Second: V_{OUT} , 200 V / div.
 Third: I_{IN} , 10 A / div.
 Bottom: V_{CC} , 10 V / div., 50 ms / div.

13.4 Start-up at 115 VAC and 60 Hz

Load in CC mode during turn-on of PFC.

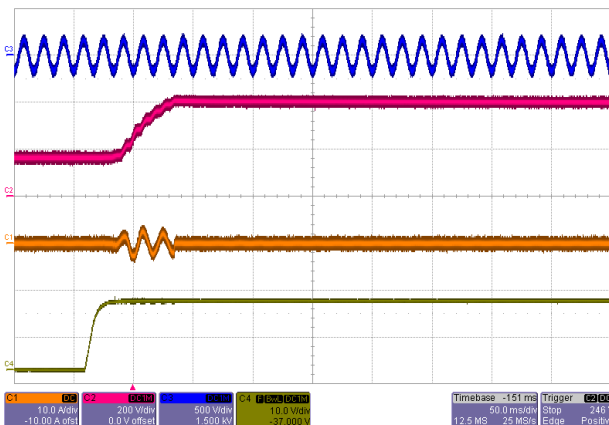

Figure 21 – 115 VAC, No Load.
 Top: V_{IN} , 500 V / div.
 Second: V_{OUT} , 200 V / div.
 Third: I_{IN} , 10 A / div.
 Bottom: V_{CC} , 10 V / div., 50 ms / div.

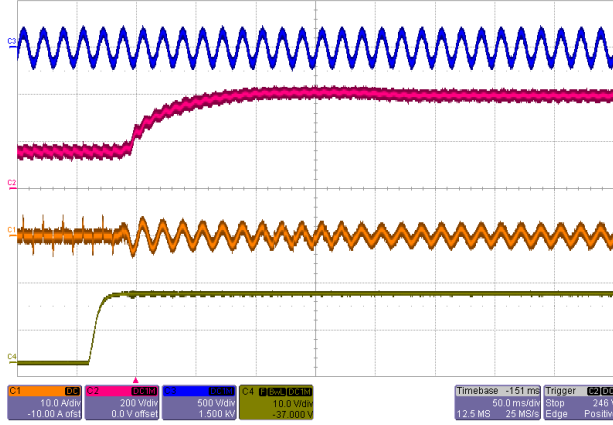

Figure 22 – 115 VAC, Full Load.
 Top: V_{IN} , 500 V / div.
 Second: V_{OUT} , 200 V / div.
 Third: I_{IN} , 10 A / div.
 Bottom: V_{CC} , 10 V / div., 50 ms / div.

13.5 Start-up at 230 VAC and 50 Hz

Load in CC mode during turn-on of PFC.

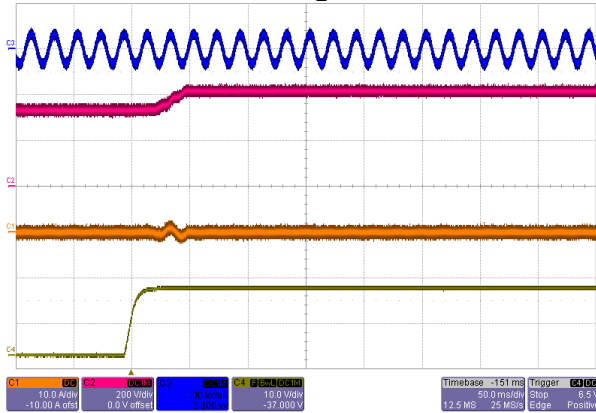

Figure 23 – 230 VAC, No-load.
 Top: V_{IN} , 1 kV / div.
 Second: V_{OUT} , 200 V / div.
 Third: I_{IN} , 10 A / div.
 Bottom: V_{CC} , 10 V, 50 ms / div.

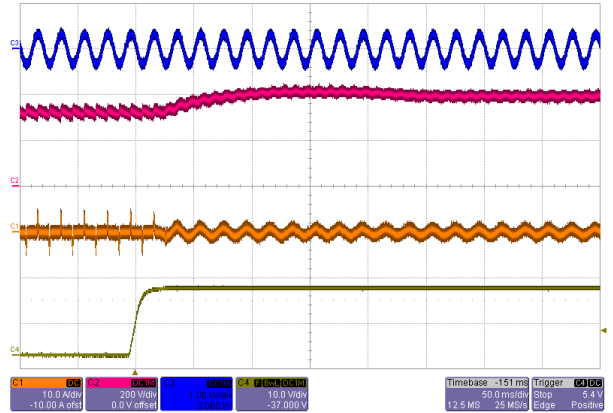

Figure 24 – 230 VAC, Full Load.
 Top: V_{IN} , 1 kV / div.
 Second: V_{OUT} , 200 V / div.
 Third: I_{IN} , 10 A / div.
 Bottom: V_{CC} , 10 V, 50 ms / div.

13.6 Start-up at 264 VAC and 50 Hz

Load in CC mode during turn-on of PFC.

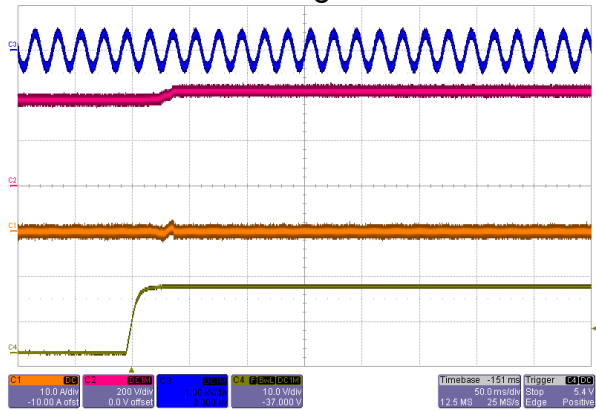

Figure 25 – 264 VAC, No-load.
 Top: V_{IN} , 1 kV / div.
 Second: V_{OUT} , 200 V / div.
 Third: I_{IN} , 10 A / div.
 Bottom: V_{CC} , 10 V, 50 ms / div.

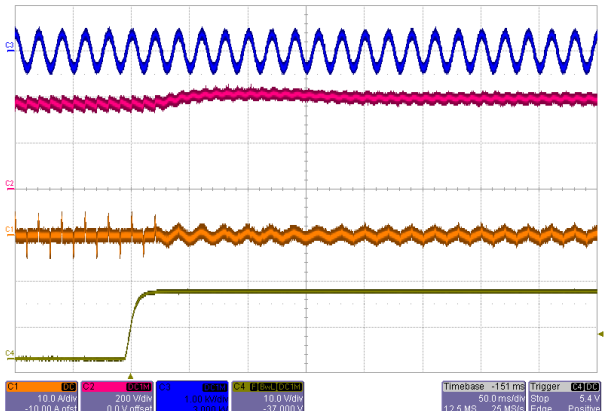

Figure 26 – 264 VAC, Full Load.
 Top: V_{IN} , 1 kV / div.
 Second: V_{OUT} , 200 V / div.
 Third: I_{IN} , 10 A / div.
 Bottom: V_{CC} , 10 V, 50 ms / div.



13.7 Load Transient Response (90 VAC / 60 Hz)

In the figures shown below, signal averaging was used to better enable viewing the load transient response. The oscilloscope was triggered using the load current step as a trigger source. Since the output switching and line frequency occur essentially at random with respect to the load transient, contributions to the output ripple from these sources will average out, leaving the contribution only from the load step response.

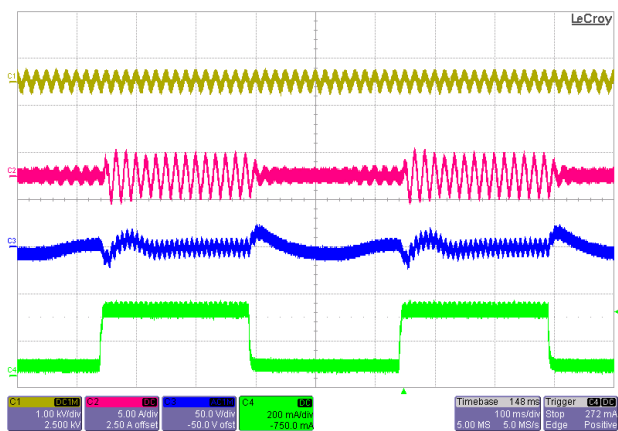

Figure 27 – Transient Response, 90 VAC,
 10–100–10% Load Step.
 Top: V_{IN} , 1 kV / div.
 Second: I_{IN} , 5 A / div.
 Third: V_{OUT} (AC Coupled), 50 V / div.
 Bottom: I_{LOAD} 200 mA, 100 ms / div.

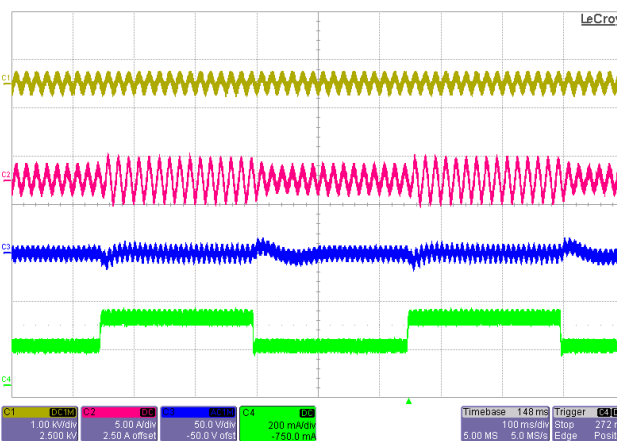

Figure 28 – Transient Response, 90 VAC,
 50–100–50% Load Step.
 Top: V_{IN} , 1 kV / div.
 Second: I_{IN} , 5 A / div.
 Third: V_{OUT} (AC Coupled), 50 V / div.
 Bottom: I_{LOAD} 200 mA, 100 ms / div.



13.8 Load Transient Response (115 VA / 60 Hz)

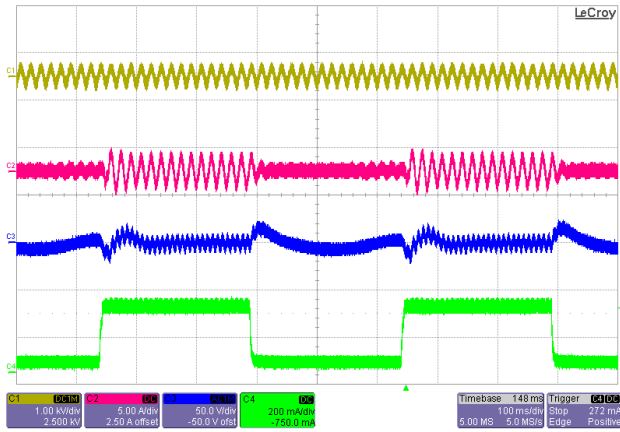

Figure 29 – Transient Response, 115 VAC,
10–100–10% Load Step.
Top: V_{IN} , 1 kV / div.
Second: I_{IN} , 5 A / div.
Third: V_{OUT} (AC Coupled), 50 V / div.
Bottom: I_{LOAD} 200 mA, 100 ms / div.

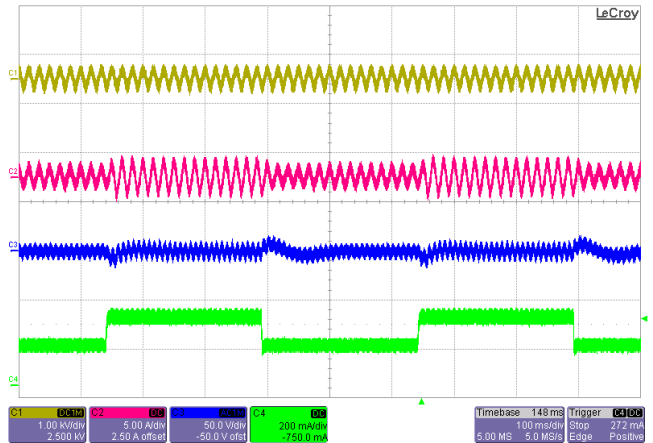

Figure 30 – Transient Response, 115 VAC,
50–100–50% Load Step.
Top: V_{IN} , 1 kV / div.
Second: I_{IN} , 5 A / div.
Third: V_{OUT} (AC Coupled), 50 V / div.
Bottom: I_{LOAD} 200 mA, 100 ms / div.

13.9 Load Transient Response (230 VAC / 50 Hz)

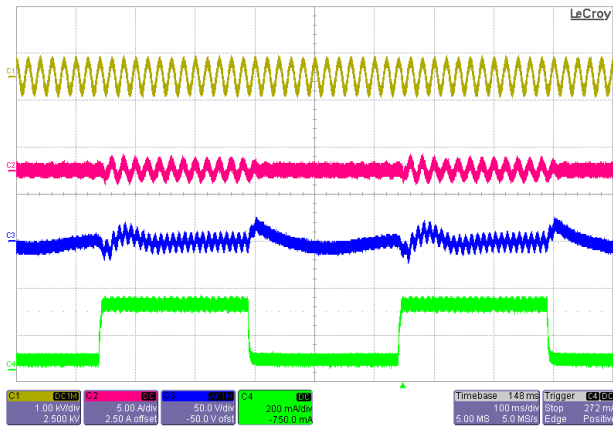

Figure 31 – Transient Response, 230 VAC,
10–100–10% Load Step.
Top: V_{IN} , 1 kV / div.
Second: I_{IN} , 5 A / div.
Third: V_{OUT} (AC Coupled), 50 V / div.
Bottom: I_{LOAD} 200 mA, 100 ms / div.

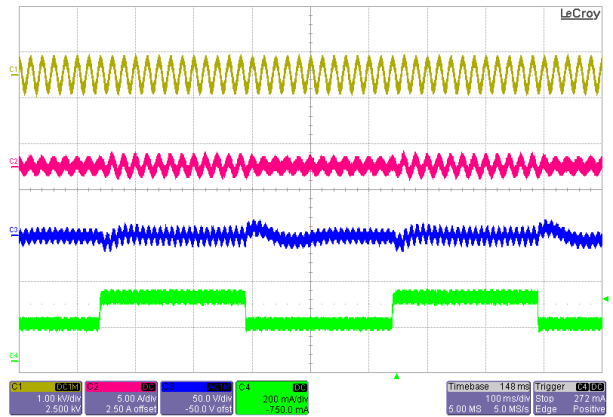

Figure 32 – Transient Response, 230 VAC,
50–100–50% Load Step.
Top: V_{IN} , 1 kV / div.
Second: I_{IN} , 5 A / div.
Third: V_{OUT} (AC Coupled), 50 V / div.
Bottom: I_{LOAD} 200 mA, 100 ms / div



13.10 Load Transient Response (264 VAC / 50 Hz)

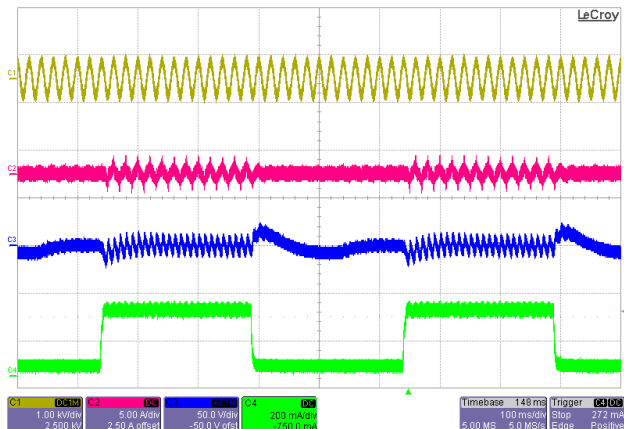

Figure 33 – Transient Response, 264 VAC, 10–100–10% Load Step.
 Top: V_{IN} , 1 kV / div.
 Second: I_{IN} , 5 A / div.
 Third: V_{OUT} (AC Coupled), 50 V / div.
 Bottom: I_{LOAD} 200 mA, 100 ms / div.

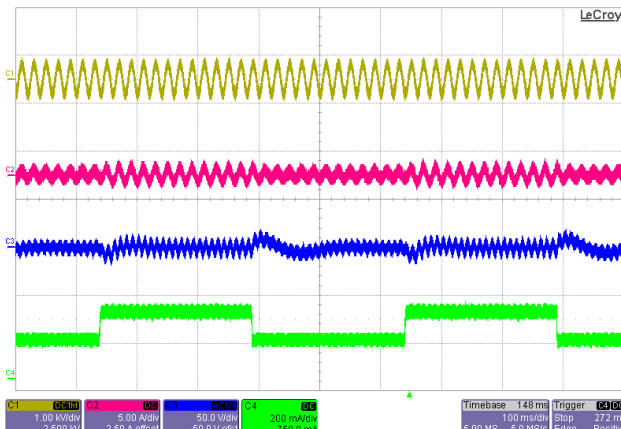

Figure 34 – Transient Response, 264 VAC, 50–100–50% Load Step.
 Top: V_{IN} , 1 kV / div.
 Second: I_{IN} , 5 A / div.
 Third: V_{OUT} (AC Coupled), 50 V / div.
 Bottom: I_{LOAD} 200 mA, 100 ms / div.

13.11 1000 ms Line Dropout (115 VC / 60 Hz and 230 VAC / 50 Hz)

13.11.1 50% Load at Output

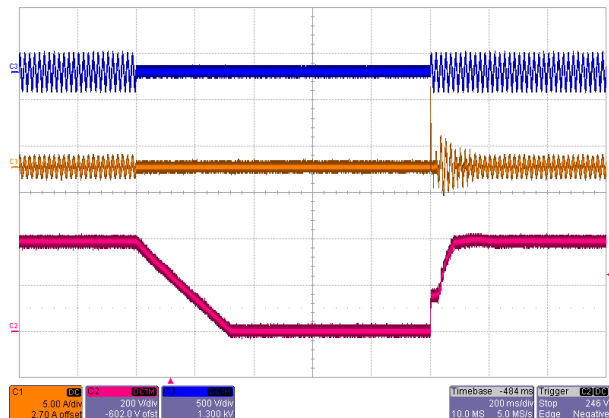

Figure 35 – Line Dropout 115 VAC, 1000 ms.
 Top: V_{IN} , 500 V / div.
 Middle: I_{IN} , 5 A / div.
 Bottom: V_{OUT} , 200 V, 200 ms / div.

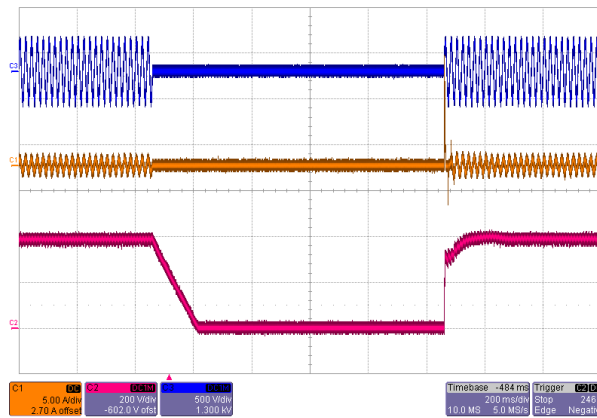

Figure 36 – Line Dropout 230 VAC, 1000 ms.
 Top: V_{IN} , 500 V / div.
 Middle: I_{IN} , 5 A / div.
 Bottom: V_{OUT} , 200 V, 200 ms / div.

13.11.2 Full Load at Output

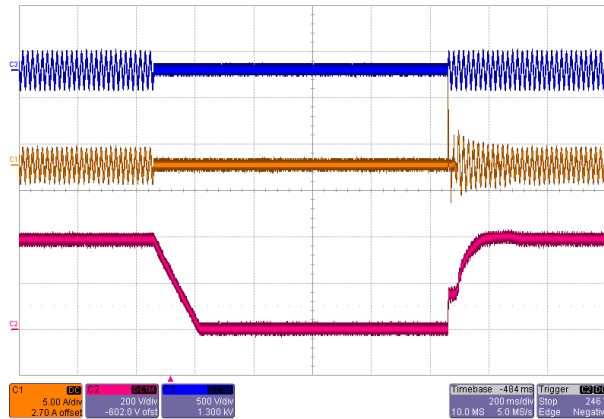

Figure 37 – Line Dropout 115 VAC, 1000 ms.
 Top: V_{IN} , 500 V / div.
 Middle: I_{IN} , 5 A / div.
 Bottom: V_{OUT} , 200 V, 200 ms / div.

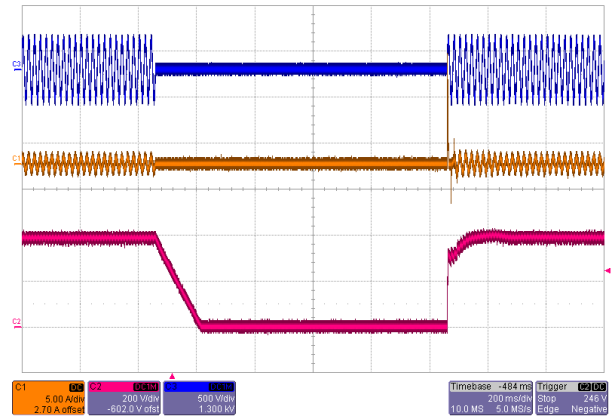

Figure 38 – Line Dropout 230 VAC, 1000 ms.
 Top: V_{IN} , 500 V / div.
 Middle: I_{IN} , 5 A / div.
 Bottom: V_{OUT} , 200 V, 200 ms / div.

13.12 One Cycle Line Dropout (115 VAC / 60 Hz and 230 VAC / 50 Hz)

13.12.1 Full Load at Output

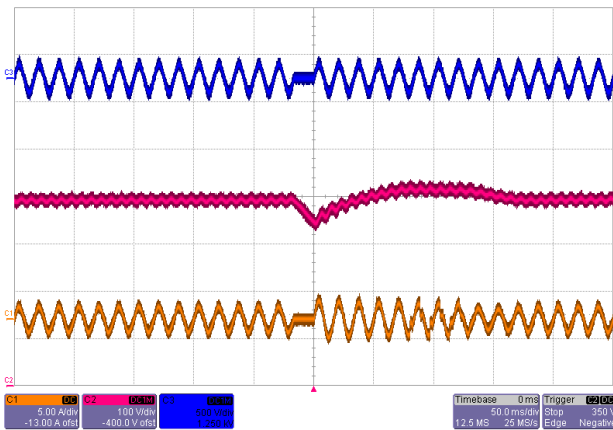

Figure 39 – Line Dropout 115 VAC, 60 Hz.
 Top: V_{IN} , 500 V / div.
 Middle: V_{OUT} , 100 V / div.
 Bottom: I_{IN} , 5 A, 50 ms / div.

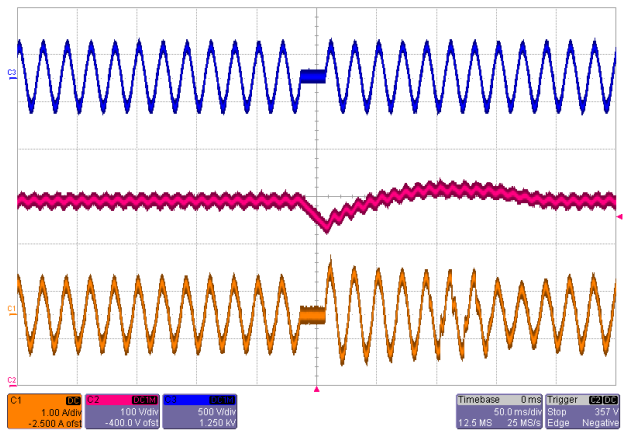

Figure 40 – Line Dropout 230 VAC, 50 Hz.
 Top: V_{IN} , 500 V / div.
 Middle: V_{OUT} , 100 V / div.
 Bottom: I_{IN} , 5 A, 50 ms / div.



13.13 Line Sag (115 VAC – 85 VAC – 115 VAC, 60 Hz)

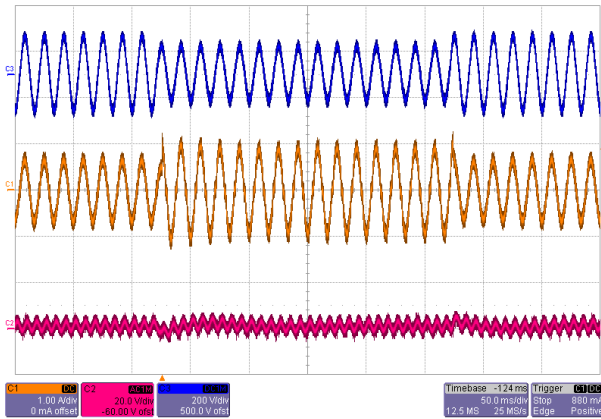

Figure 41 – Line Sag 115 VAC, 50% Load.
 Top: V_{IN} , 200 V / div.
 Middle: I_{IN} , 1 A, 50 ms / div.
 Bottom: V_{OUT} (AC Coupled), 20 V / div.

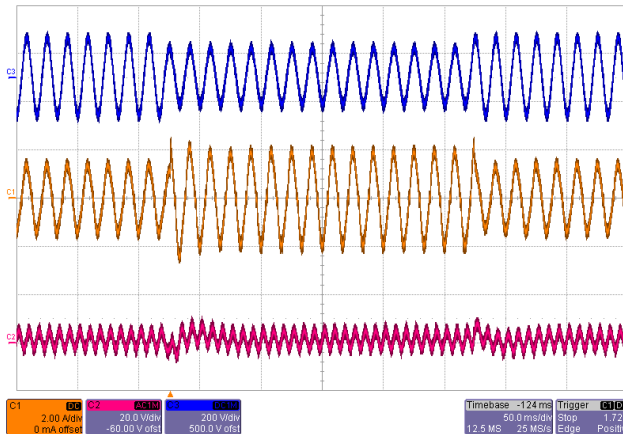

Figure 42 – Line Sag 115 VAC, 100% Load.
 Top: V_{IN} , 200 V / div.
 Middle: I_{IN} , 2 A, 50 ms / div.
 Bottom: V_{OUT} (AC Coupled), 20 V / div.

13.14 Line Surge (132 VAC – 147 VAC – 132 VAC, 60 Hz)

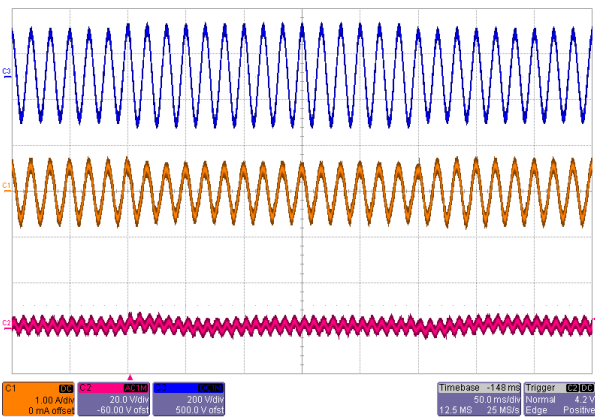

Figure 43 – Line Surge 132 VAC, 50% Load.
 Top: V_{IN} , 200 V / div.
 Middle: I_{IN} , 1 A, 50 ms / div.
 Bottom: V_{OUT} (AC Coupled), 20 V / div.

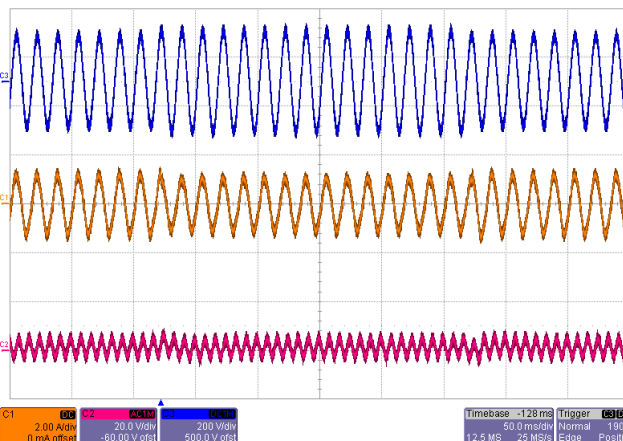

Figure 44 – Line Surge 132 VAC, 100% Load.
 Top: V_{IN} , 200 V / div.
 Middle: I_{IN} , 2 A, 50 ms / div.
 Bottom: V_{OUT} (AC Coupled), 20 V / div.

13.15 Line Sag (230 VAC – 170 VAC – 230 VAC, 50 Hz)

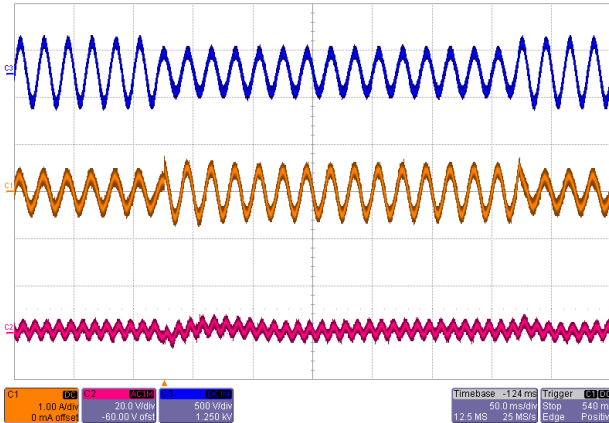

Figure 45 – Line Sag 230 VAC, 50% Load.
 Top: V_{IN} , 500 V / div.
 Middle: I_{IN} , 1 A, 50 ms / div.
 Bottom: V_{OUT} (AC Coupled), 20 V / div.

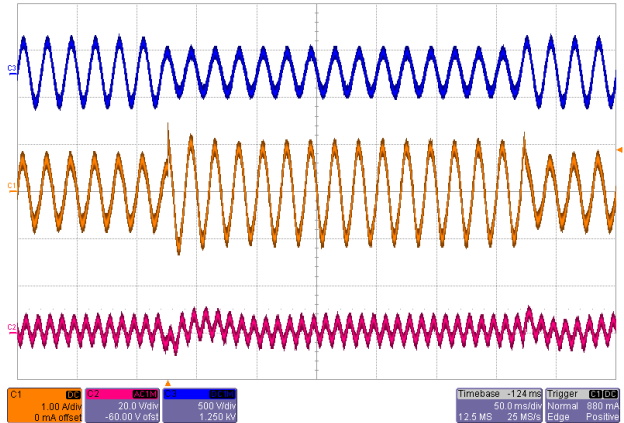

Figure 46 – Line Sag 230 VAC, 100% Load.
 Top: V_{IN} , 500 V / div.
 Middle: I_{IN} , 1 A, 50 ms / div.
 Bottom: V_{OUT} (AC Coupled), 20 V / div.

13.16 Line Surge (264 VAC – 293 VAC – 264 VAC, 50 Hz)

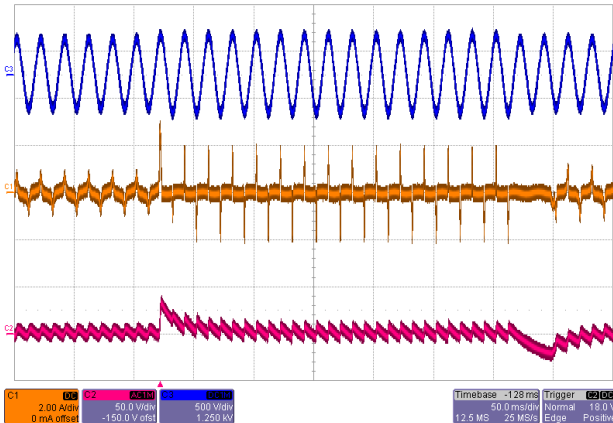

Figure 47 – Line Surge 264 VAC, 50% Load.
 Top: V_{IN} , 500 V / div.
 Middle: I_{IN} , 2 A, 50 ms / div.
 Bottom: V_{OUT} (AC Coupled), 50 V / div.

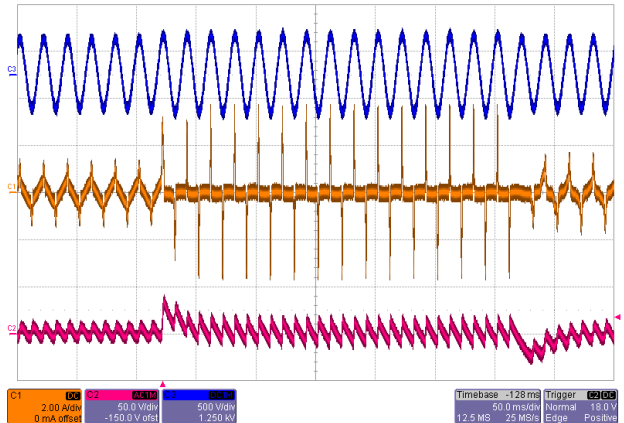

Figure 48 – Line Surge 264 VAC, 100% Load.
 Top: V_{IN} , 500 V / div.
 Middle: I_{IN} , 2 A, 50 ms / div.
 Bottom: V_{OUT} (AC Coupled), 50 V / div.



13.17 Brown-In and Brown-Out at Full Load

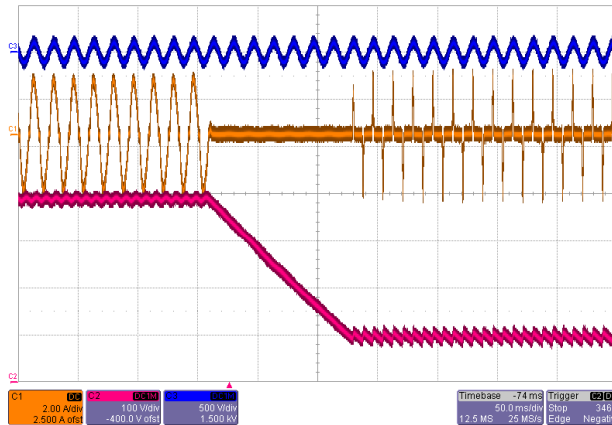

Figure 49 – Brown-out.
 Top: V_{IN} , 500 V / div.
 Middle: I_{IN} , 2 A, 50 ms / div.
 Bottom: V_{OUT} , 100 V / div.

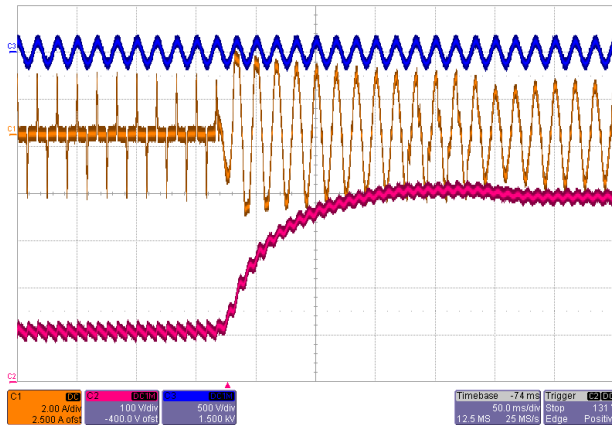

Figure 50 – Brown-in.
 Top: V_{IN} , 500 V / div.
 Middle: I_{IN} , 2 A, 50 ms / div.
 Bottom: V_{OUT} , 100 V / div.

Measured Brown-out Voltage: 71 VAC
 Measured Brown-in Voltage: 82 VAC

13.18 Output Ripple Measurements

13.18.1 Ripple Measurement Technique

For DC output ripple measurements, a modified oscilloscope test probe must be utilized in order to reduce spurious signals due to pickup. Details of the probe modification are provided in the figures below.

The 4987BA probe adapter is affixed with one capacitor 0.02 μ F/1 kV ceramic disc type tied in parallel across the probe tip.

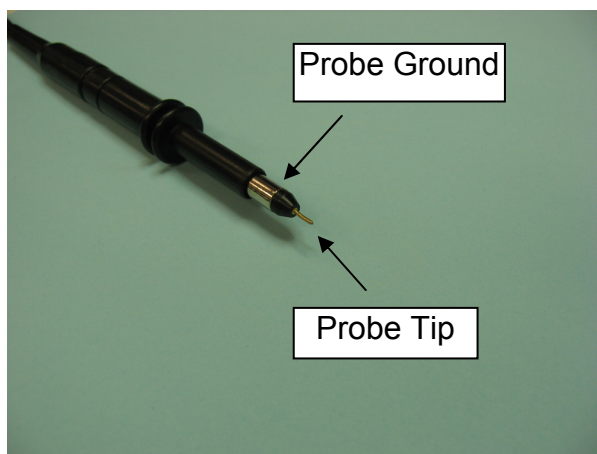

Figure 51 – Oscilloscope Probe Prepared for Ripple Measurement (End Cap and Ground Lead Removed).



Figure 52 – Oscilloscope Probe with Probe Master (www.probemaster.com) 4987A BNC Adapter. Modified with wires for ripple measurement, and one parallel decoupling capacitor added.)

13.18.2 Measurement Results

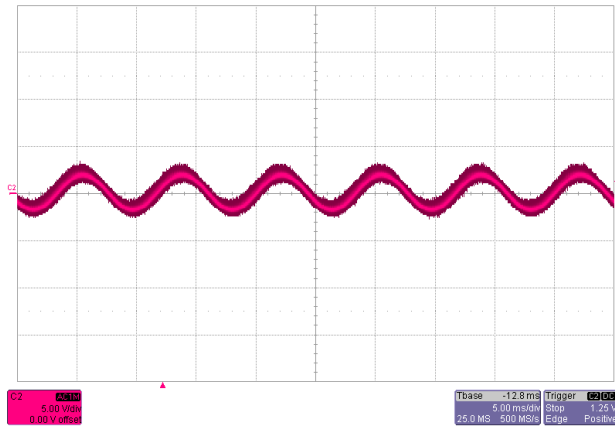

Figure 53 – Ripple, 90 VAC, 50% Load.
5 ms, 5 V / div.

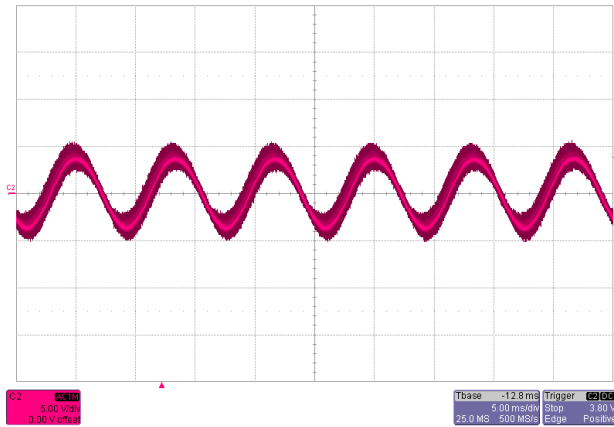

Figure 54 – Ripple, 90 VAC, 100% Load.
5 ms, 5 V / div.

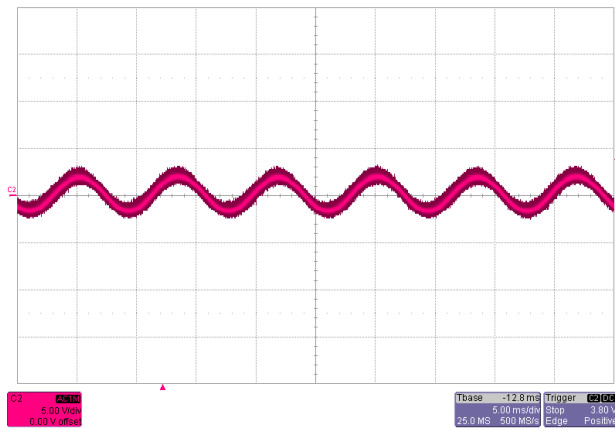

Figure 55 – Ripple, 115 VAC, 50% Load.
5 ms, 5 V / div.

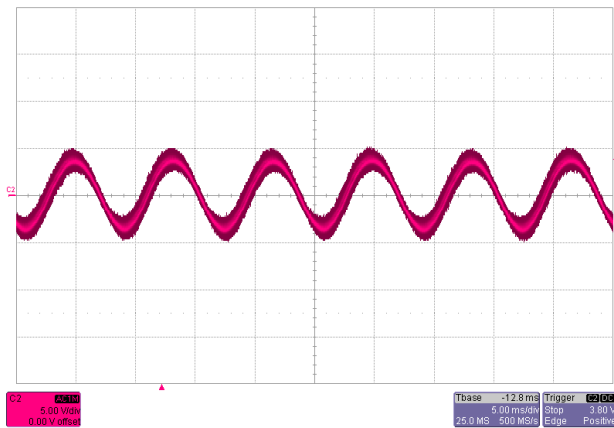

Figure 56 – Ripple, 115 VAC, 100% Load.
5 ms, 5 V / div.

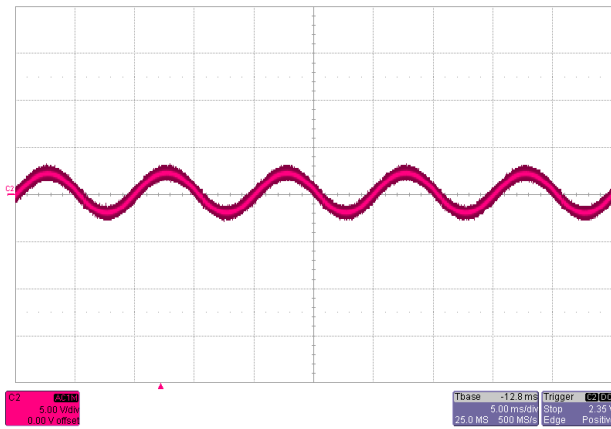

Figure 57 – Ripple, 230 VAC, 50% Load.
5 ms, 5 V / div.

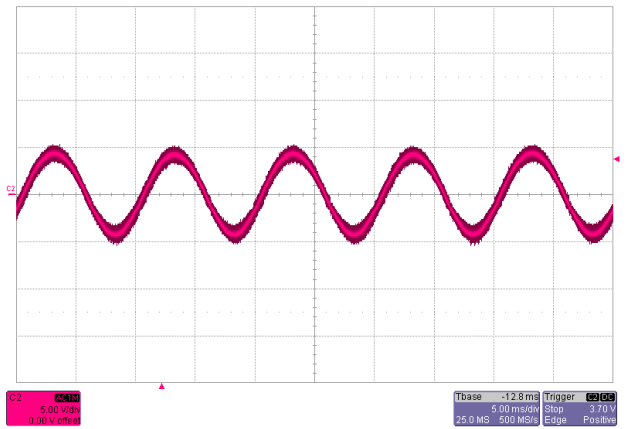

Figure 58 – Ripple, 230 VAC, 100% Load.
5 ms, 5 V / div.

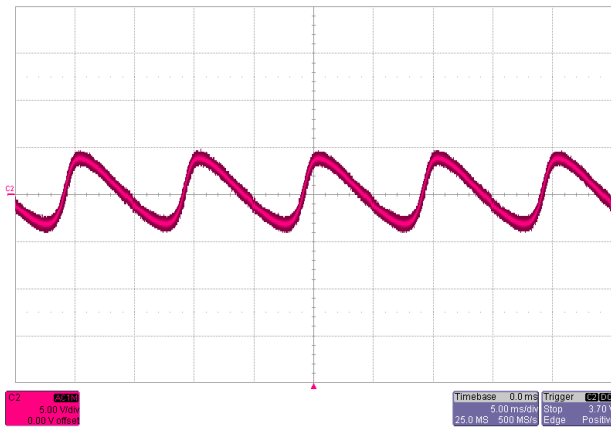

Figure 59 – Ripple, 264 VAC, 50% Load.
5 ms, 5 V / div.

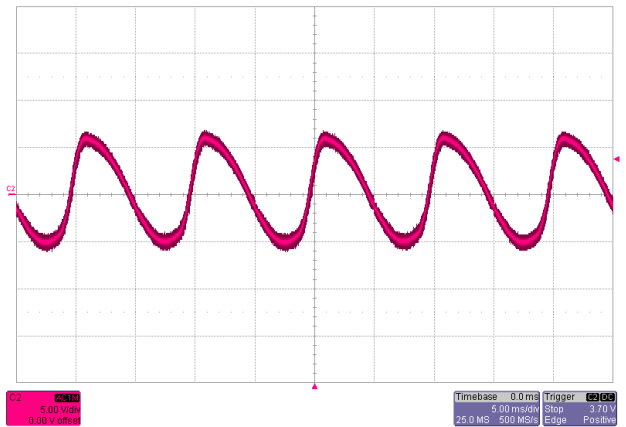

Figure 60 – Ripple, 264 VAC, 100% Load.
5 ms, 5 V / div.



14 Line Surge Test

Differential surge test results to IEC6100-4-5.

Surge Level (V)	Input Voltage (VAC)	Injection Location (2 Ω source)	Injection Phase (°)	Test Results (Pass/Fail # Strikes)
+500	230	L1 to L2	90	Pass
-500	230	L1 to L2	270	Pass
+1000	230	L1 to L2	90	Pass
-1000	230	L1 to L2	270	Pass



15 EMI Scans at Full Load

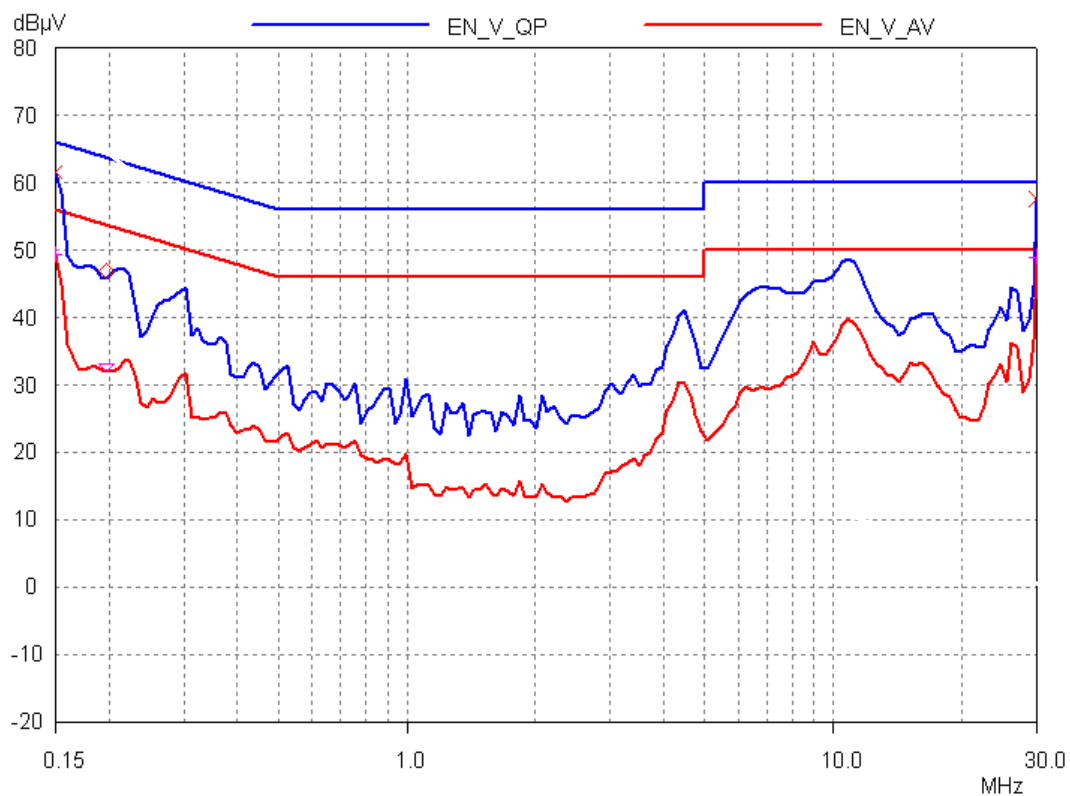

Figure 61 – 115 VAC, Line.



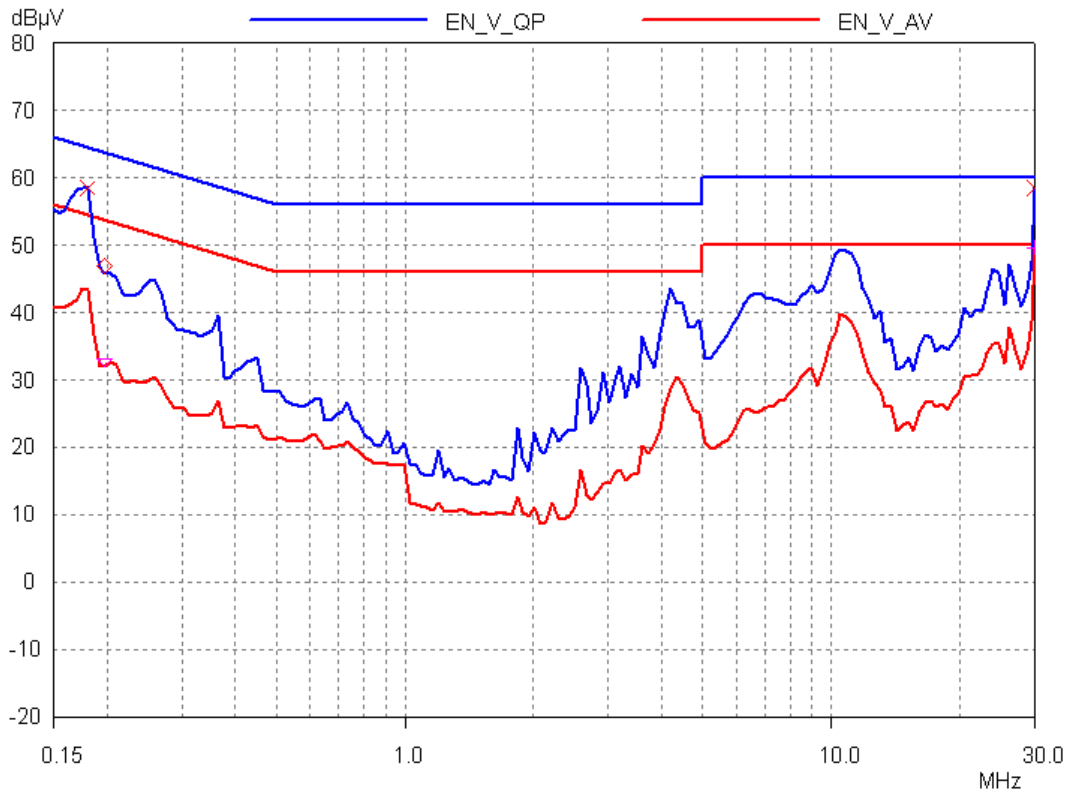

Figure 62 – 115 VAC, Neutral.



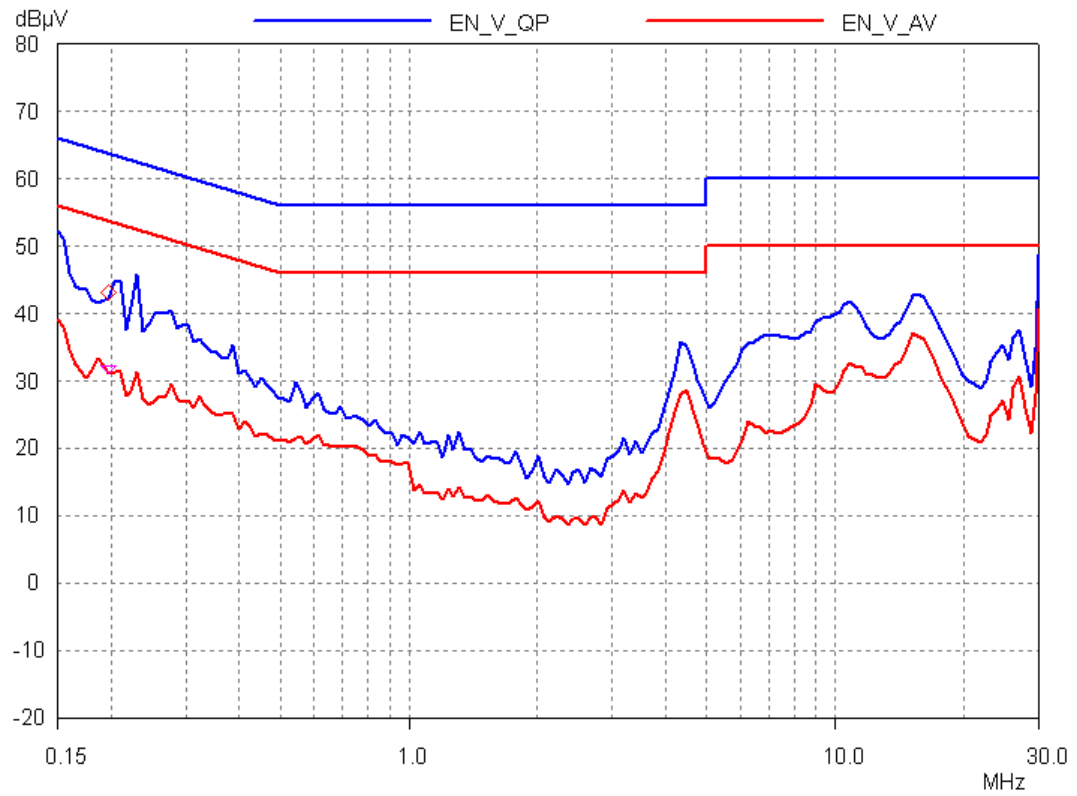

Figure 63 – 230 VAC, Line.



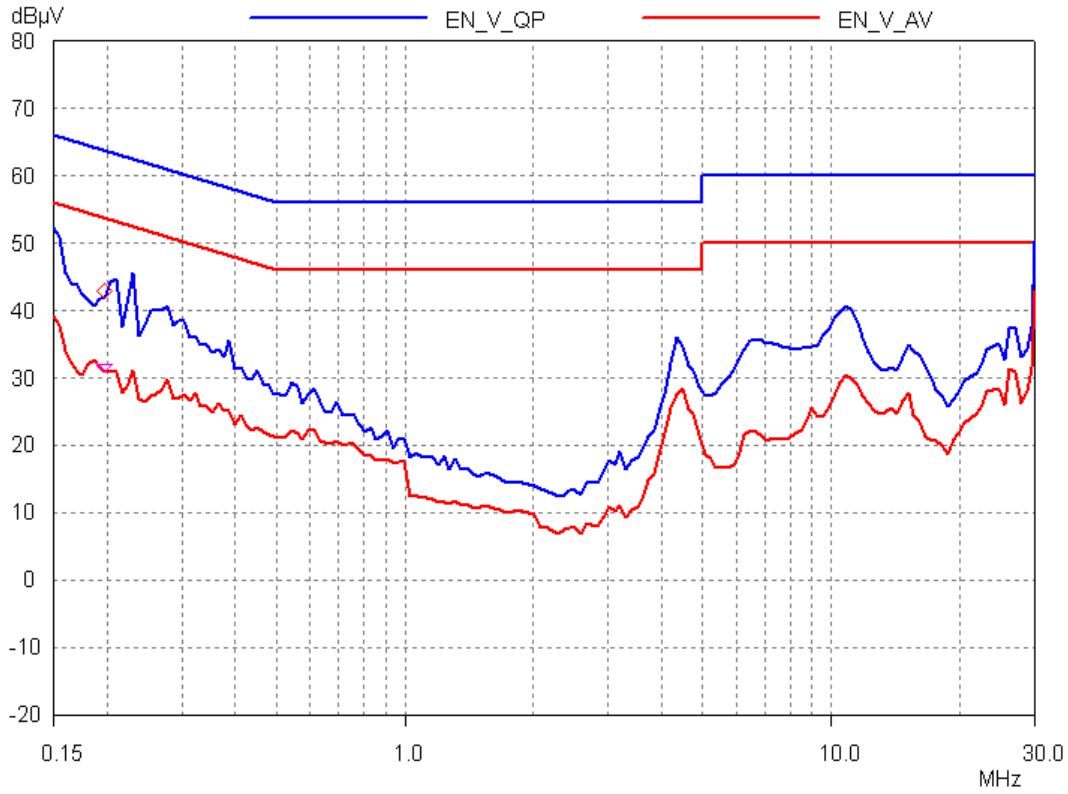

Figure 64 – 230 VAC, Neutral.



16 Revision History

Date	Author	Revision	Description and changes	Reviewed
25-Feb-11	EJ	1.0	Initial Release	Apps & Mktg
13-Apr-12	KM	1.1	Updated Schematic, BOM and Inductor	

For the latest updates, visit our website: www.powerint.com

Power Integrations reserves the right to make changes to its products at any time to improve reliability or manufacturability. Power Integrations does not assume any liability arising from the use of any device or circuit described herein. POWER INTEGRATIONS MAKES NO WARRANTY HEREIN AND SPECIFICALLY DISCLAIMS ALL WARRANTIES INCLUDING, WITHOUT LIMITATION, THE IMPLIED WARRANTIES OF MERCHANTABILITY, FITNESS FOR A PARTICULAR PURPOSE, AND NON-INFRINGEMENT OF THIRD PARTY RIGHTS.

PATENT INFORMATION

The products and applications illustrated herein (including transformer construction and circuits' external to the products) may be covered by one or more U.S. and foreign patents, or potentially by pending U.S. and foreign patent applications assigned to Power Integrations. A complete list of Power Integrations' patents may be found at www.powerint.com. Power Integrations grants its customers a license under certain patent rights as set forth at <http://www.powerint.com/ip.htm>.

The PI Logo, TOPSwitch, TinySwitch, LinkSwitch, DPA-Switch, PeakSwitch, CAPZero, SENZero, LinkZero, HiperPFS, HiperTFS, HiperLCS, Qspeed, EcoSmart, Clampless, E-Shield, Filterfuse, StackFET, PI Expert and PI FACTS are trademarks of Power Integrations, Inc. Other trademarks are property of their respective companies. ©Copyright 2012 Power Integrations, Inc.

Power Integrations Worldwide Sales Support Locations**WORLD HEADQUARTERS**

5245 Hellyer Avenue
San Jose, CA 95138, USA.
Main: +1-408-414-9200
Customer Service:
Phone: +1-408-414-9665
Fax: +1-408-414-9765
e-mail: usasales@powerint.com

GERMANY

Lindwurmstrasse 114
80337, Munich
Germany
Phone: +49-895-527-39110
Fax: +49-895-527-39200
e-mail: eurosales@powerint.com

JAPAN

Kosei Dai-3 Building
2-12-11, Shin-Yokohama,
Kohoku-ku, Yokohama-shi,
Kanagawa 222-0033
Japan
Phone: +81-45-471-1021
Fax: +81-45-471-3717
e-mail: japansales@powerint.com

TAIWAN

5F, No. 318, Nei Hu Rd.,
Sec. 1
Nei Hu District
Taipei 114, Taiwan R.O.C.
Phone: +886-2-2659-4570
Fax: +886-2-2659-4550
e-mail: taiwansales@powerint.com

CHINA (SHANGHAI)

Rm 1601/1610, Tower 1
Kerry Everbright City
No. 218 Tianmu Road West
Shanghai, P.R.C. 200070
Phone: +86-021-6354-6323
Fax: +86-021-6354-6325
e-mail: chinasales@powerint.com

INDIA

#1, 14th Main Road
Vasanthanagar
Bangalore-560052
India
Phone: +91-80-4113-8020
Fax: +91-80-4113-8023
e-mail: indiasales@powerint.com

KOREA

RM 602, 6FL
Korea City Air Terminal B/D,
159-6
Samsung-Dong, Kangnam-Gu,
Seoul, 135-728 Korea
Phone: +82-2-2016-6610
Fax: +82-2-2016-6630
e-mail: koreasales@powerint.com

EUROPE HQ

1st Floor, St. James's House
East Street, Farnham
Surrey GU9 7TJ
United Kingdom
Phone: +44 (0) 1252-730-141
Fax: +44 (0) 1252-727-689
e-mail: eurosales@powerint.com

CHINA (SHENZHEN)

3rd Floor, Block A, Zhongtuo
International Business Center, No.
1061, Xiang Mei Road, FuTian District,
ShenZhen, China, 518040
Phone: +86-755-8379-3243
Fax: +86-755-8379-5828
e-mail: chinasales@powerint.com

ITALY

Via Milanese 20, 3rd Fl.
20099 Sesto San Giovanni
(MI) Italy
Phone: +39-024-550-8701
Fax: +39-028-928-6009
e-mail: eurosales@powerint.com

SINGAPORE

51 Newton Road,
#19-01/05 Goldhill Plaza
Singapore, 308900
Phone: +65-6358-2160
Fax: +65-6358-2015
e-mail: singaporesales@powerint.com

APPLICATIONS HOTLINE

World Wide +1-408-414-9660

APPLICATIONS FAX

World Wide +1-408-414-9760

