



Design Example Report

Title	<i>20 W and 30 W Boost Converters with Constant Current Output using DPA423G and DPA424G</i>
Specification	Input: 24 VDC Board #1 Output: 40 V / 500 mA CC Board #2 Output: 60 V / 500 mA CC
Application	LED (RGB) Backlight for LCD TV
Author	Power Integrations Applications Department
Document Number	DER-112
Date	July 19, 2006
Revision	1.1

Summary and Features

- Boost Converter using DPA423 (20 W) and DPA424 (30 W)
- Simple Low Component Count
- High Efficiency (> 90 %)
- CC/CV (Constant Current and Constant Voltage)
- 400 KHz operation

The products and applications illustrated herein (including circuits external to the products and transformer construction) may be covered by one or more U.S. and foreign patents or potentially by pending U.S. and foreign patent applications assigned to Power Integrations. A complete list of Power Integrations' patents may be found at www.powerint.com.

Table Of Contents

1	Introduction	3
2	Power Supply Specification	6
2.1	Board 1 (40 V Output).....	6
2.2	Board 2 (60 V Output).....	6
3	Schematic.....	7
3.1	Schematic of Board 1 (40 V Output).....	7
3.2	Schematic of Board 2 (60 V Output).....	8
4	BOM.....	9
4.1	Bill of Materials – Board 1 (40 V)	9
4.2	Bill of Materials – Board 2 (60 V)	10
5	Layout.....	11
6	Performance	12
6.1	Efficiency	12
6.2	Regulation vs. Load (40 V)	13
6.3	Regulation vs. Load (60 V)	14
7	Performance	15
7.1	Raw Performance Data – 60V Board.....	15
7.2	Raw Performance Data – 40 V Board.....	15
8	Revision History	16

Important Note:

This board is designed to be non-isolated. However the outputs are high voltage so please take the necessary safety precautions.

Design Reports contain a power supply design specification, schematic, bill of materials, and transformer documentation. Performance data and typical operation characteristics are included. Typically only a single prototype has been built.



1 Introduction

This document is an engineering report describing two constant current and constant voltage (CC/CV) power supplies utilizing DPA423G (at 20 W) and DPA424G (at 30 W). The power supplies operate from an input of 24 VDC. The power supply is constant-current regulated (to 500 mA) but operates as a voltage regulator at lower power.

This document provides complete design information including specification, schematic, bill of material and layout information.

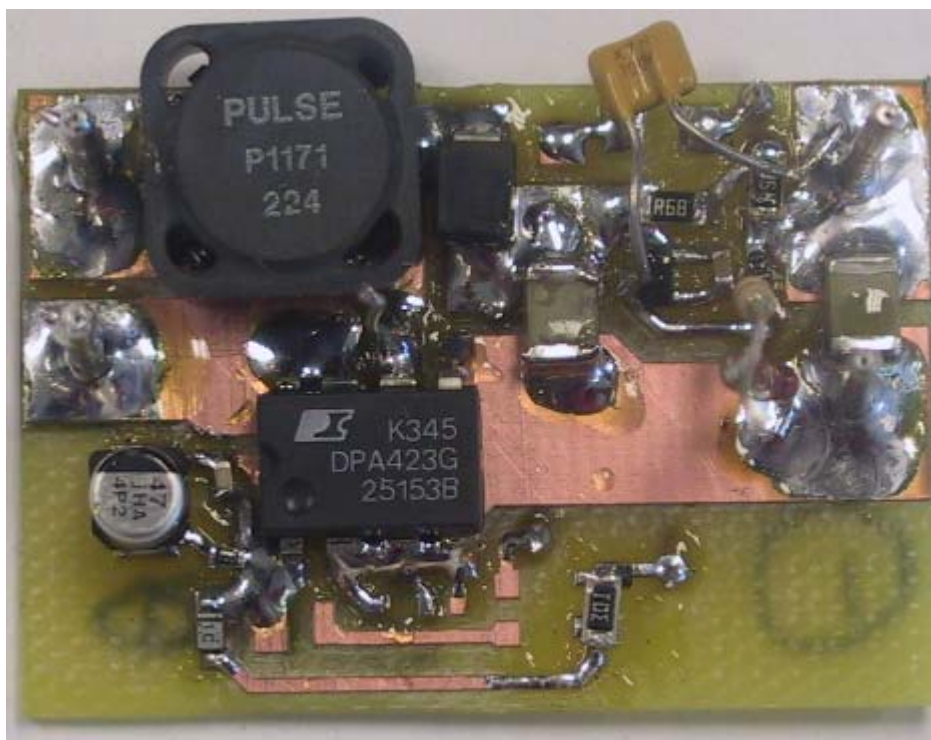

Figure 1 – Photograph – Top View – Board 1.



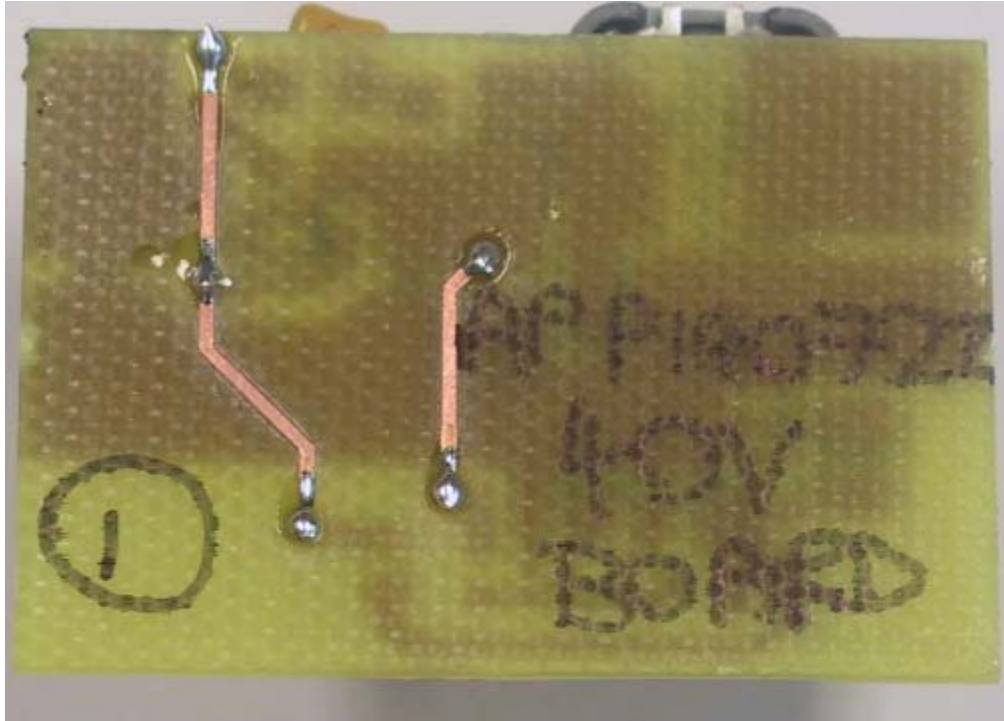

Figure 2 – Photograph – Bottom View – Board 1.

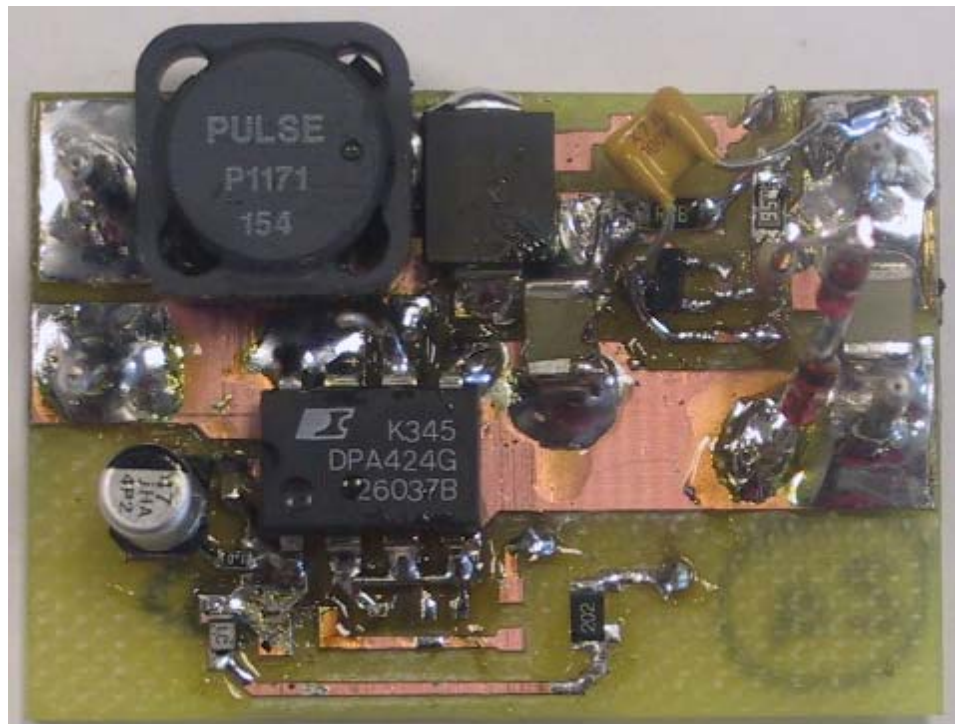

Figure 3 – Photograph – Top View – Board 2.

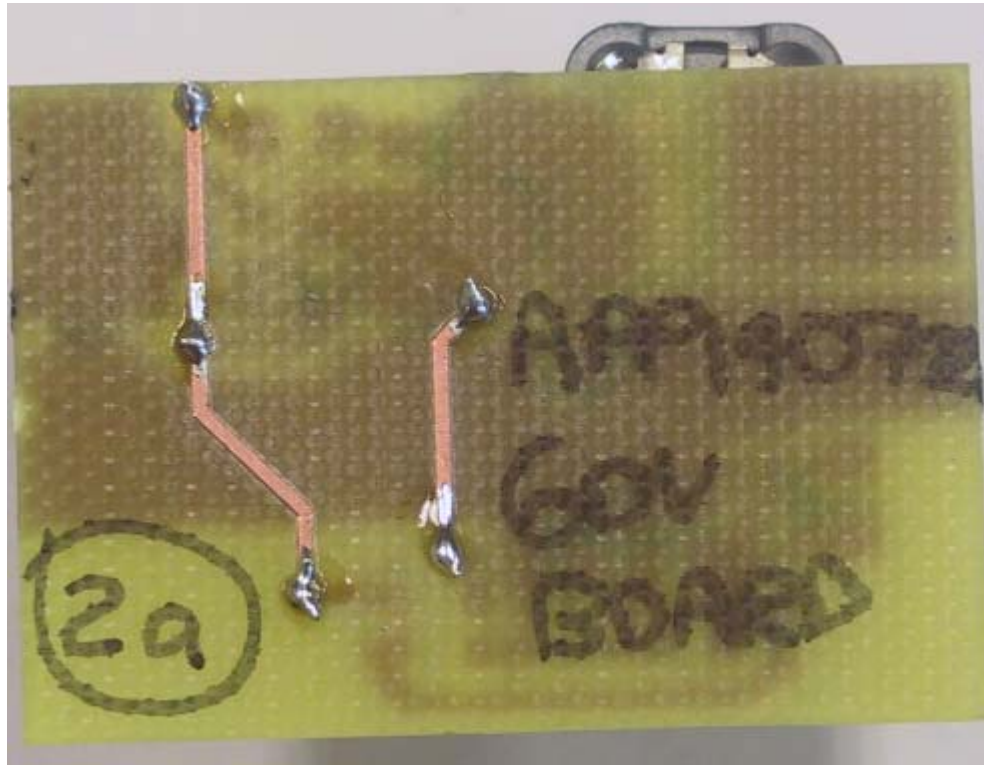

Figure 4 - Photograph - Bottom View – Board 2.



2 Power Supply Specification

2.1 Board 1 (40 V Output)

Description	Symbol	Min	Typ	Max	Units	Comment
Input Voltage	V_{IN}		24		VDC	
Output Output Voltage 1 Output Ripple Voltage 1 Output Current 1	V_{OUT1} $V_{RIPPLE1}$ I_{OUT1}		40 500		V mVp-p mA	$\pm 3\%$ 20 MHz bandwidth $\pm 20\%$
Total Output Power Average Output Power	P_{OUT1}		20		W	
Full Load Efficiency	η		90		%	
Environmental Ambient Temperature	T_{AMB}	0		40	$^{\circ}\text{C}$	

2.2 Board 2 (60 V Output)

Description	Symbol	Min	Typ	Max	Units	Comment
Input Voltage	V_{IN}		24		VDC	
Output Output Voltage 1 Output Ripple Voltage 1 Output Current 1	V_{OUT1} $V_{RIPPLE1}$ I_{OUT1}		60 500		V mVp-p mA	$\pm 3\%$ 20 MHz bandwidth $\pm 20\%$
Total Output Power Average Output Power	P_{OUT1}		30		W	
Full Load Efficiency	η		90		%	
Environmental Ambient Temperature	T_{AMB}	0		40	$^{\circ}\text{C}$	



3 Schematic

3.1 Schematic of Board 1 (40 V Output)

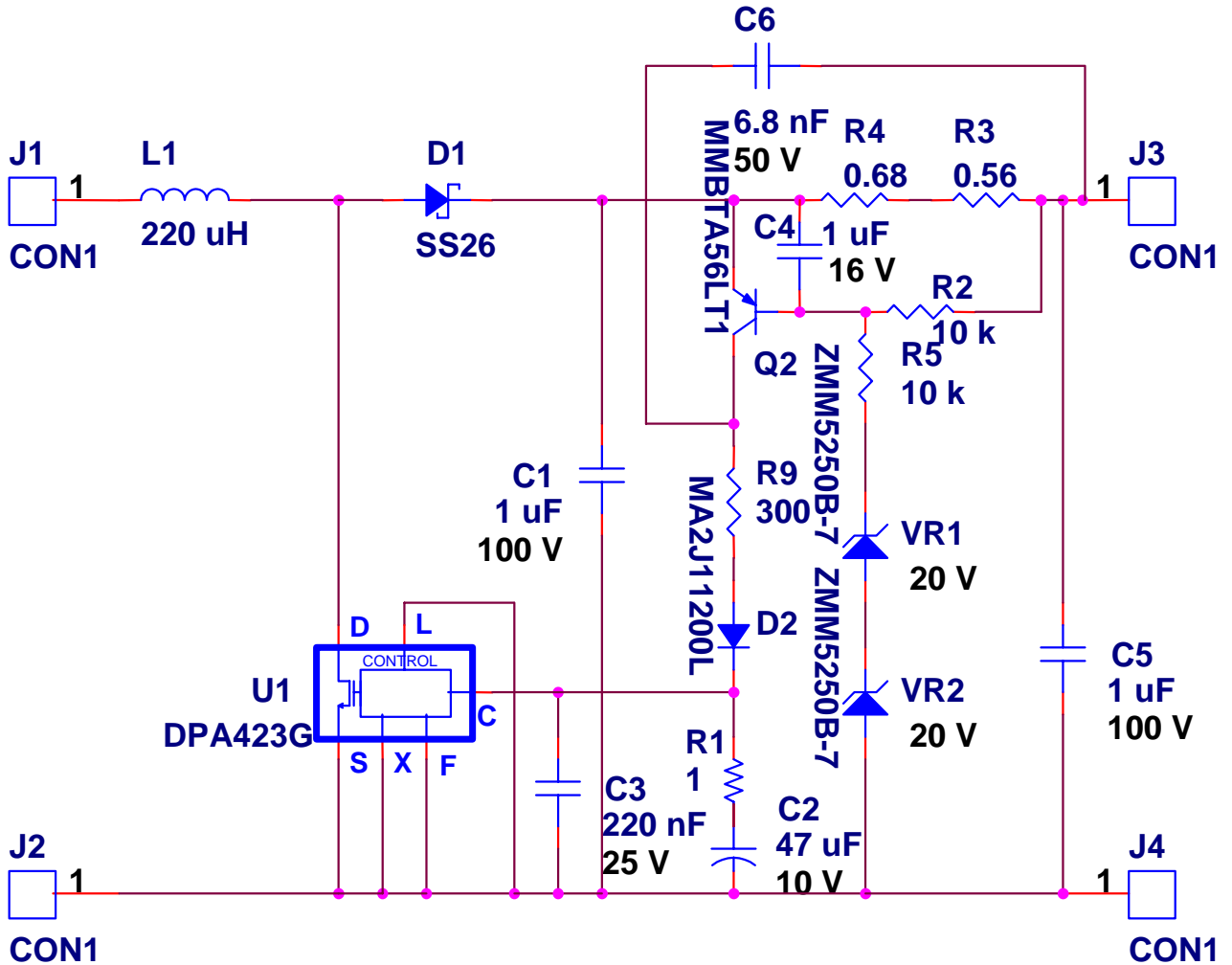

Figure 5 – Schematic.



3.2 Schematic of Board 2 (60 V Output)

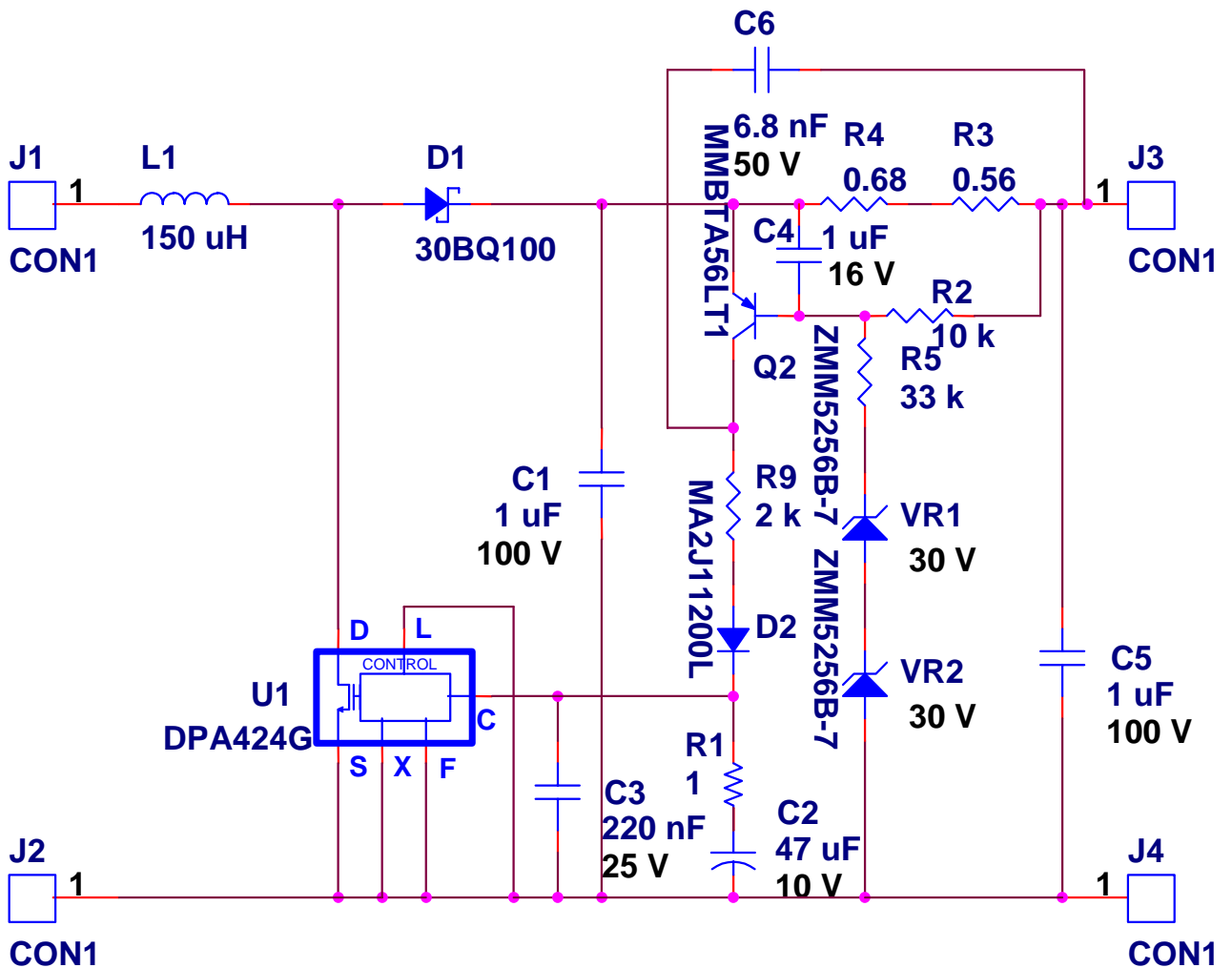

Figure 6 – Schematic.



4 BOM

4.1 Bill of Materials – Board 1 (40 V)

Item	Qty.	Ref.	Description	Mfg Part Number	Mfg
1	2	C1 C5	1 uF, 100 V, Ceramic, X7R, 1210	12101C105KAT2A	AVX
2	1	C2	47 uF, 10 V, Tant Electrolytic, B Case, SMD	T491B476M010AS	Kemet
3	1	C3	220 nF, 25 V, Ceramic, X7R, 0603	06033D224KAT2A	AVX
4	1	C4	1 uF, 16 V, Ceramic, X5R, 0603	GRM188R61C105KA 93D	Murata
5	1	C6	6.8 nF, 50 V, Ceramic, X7R, 0805	ECJ-2VB1H682K	Panasonic
6	1	D1	60 V, 2 A, Schottky, SMD, DO-214AA	SS26	Vishay
7	1	D2	40 V, 0.2 A, Switching, 50 ns, Smini 2p	MA2J11200L	Panasonic
8	4	J1 J2 J3 J4	Test Point, 0.060 (1.529mm) Dia X 0.580 (14.73 mm) long Brass, Ti over Cu, SMT	1248-580-SP	Zierick
9	1	L1	220 uH, 1.00 A, SMD	P1171.224T	Pulse
10	1	Q2	PNP, Small Signal BJT, 80 V, 0.5 A, SOT- 23	MMBTA56LT1	On Semiconductor
11	1	R1	1 R, 5%, 1/10 W, Metal Film, 0603	ERJ-3GEYJ1R0V	Panasonic
12	2	R2 R5	10 K, 5%, 1/10 W, Metal Film, 0603	ERJ-3GEYJ103V	Panasonic
13	1	R3	0.56 R, 1%, 1/4 W, Metal Film, 1206	ERJ-8RQJR56V	Panasonic
14	1	R4	0.68 R, 1%, 1/4 W, Metal Film, 1206	ERJ-8RQJR68V	Panasonic
15	1	R9	300 R, 5%, 1/4 W, Metal Film, 1206	ERJ-8GEYJ301V	Panasonic
16	1	U1	DPA-Switch, DPA423G, SMD-8	DPA423G	Power Integrations
17	2	VR1 VR2	20 V, 5%, 500 mW, DO-213AA (MELF)	ZMM5250B-7	Diodes Inc
	23	Total			



4.2 Bill of Materials – Board 2 (60 V)

Item	Qty.	Ref.	Description	Mfg Part Number	Mfg
1	2	C1 C5	1 uF, 100 V, Ceramic, X7R, 1210	12101C105KAT2A	AVX
2	1	C2	47 uF, 10 V, Tant Electrolytic, B Case, SMD	T491B476M010AS	Kemet
3	1	C3	220 nF, 25 V, Ceramic, X7R, 0603	06033D224KAT2A	AVX
4	1	C4	1 uF, 16 V, Ceramic, X5R, 0603	GRM188R61C105KA93D	Murata
5	1	C6	6.8 nF, 50 V, Ceramic, X7R, 0805	ECJ-2VB1H682K	Panasonic
6	1	D1	100V, 3 A, Schottky, SMC	30BQ100	International Rectifier
7	1	D2	40 V, 0.2 A, Switching, 50 ns, Smini 2p	MA2J11200L	Panasonic
8	4	J1 J2 J3 J4	Test Point, 0.060 (1.529mm) Dia X 0.580 (14.73 mm) long Brass, Ti over Cu, SMT	1248-580-SP	Zierick
9	1	L1	150 uH, 1.20 A, SMD	P1171.154T	Pulse
10	1	Q2	PNP, Small Signal BJT, 80 V, 0.5 A, SOT-23	MMBTA56LT1	On Semiconductor
11	1	R1	1 R, 5%, 1/10 W, Metal Film, 0603	ERJ-3GEYJ1R0V	Panasonic
12	1	R2	10 K, 5%, 1/10 W, Metal Film, 0603	ERJ-3GEYJ103V	Panasonic
13	1	R3	0.56R, 1%, 1/4 W, Metal Film, 1206	ERJ-8RQJR56V	Panasonic
14	1	R4	0.68 R, 1%, 1/4 W, Metal Film, 1206	ERJ-8RQJR68V	Panasonic
15	1	R5	33 K, 5%, 1/10 W, Metal Film, 0603	ERJ-3GEYJ333V	Panasonic
16	1	R9	2 K, 5%, 1/4 W, Metal Film, 1206	ERJ-8GEYJ202V	Panasonic
17	1	U1	DPA-Switch, DPA424G, SMD-8	DPA424G	Power Integrations
18	2	VR1 VR2	30 V, 5%, 500 mW, DO-213AA (MELF)	ZMM5256B-7	Diodes Inc
	23	Total			



5 Layout

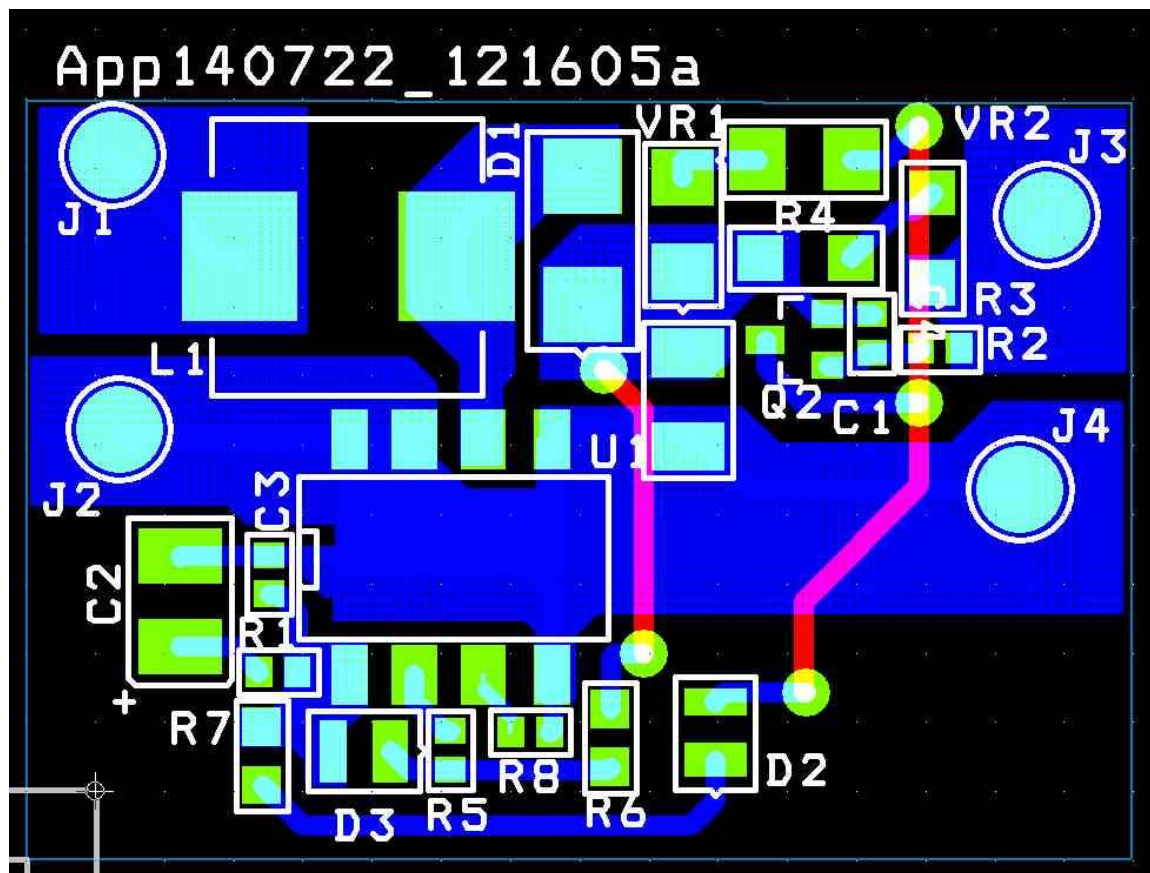

Figure 7 – Layout

Note: Please note that the layout above was used, but several component changes occurred. The schematic correctly reflects these changes. The photograph of the board will help in identifying these changes also.



6 Performance

6.1 Efficiency

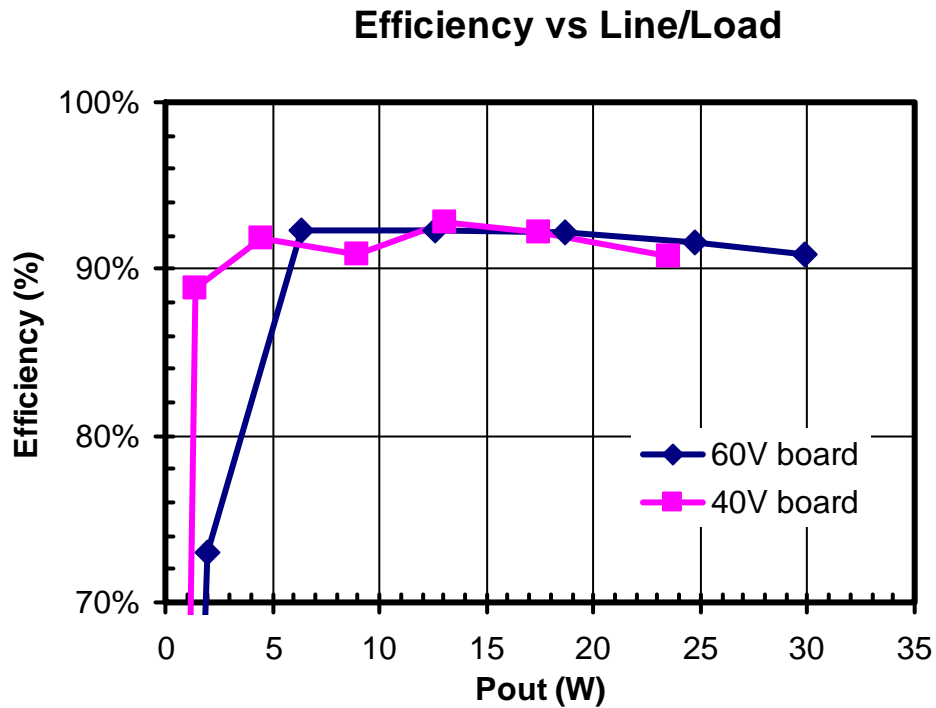

Figure 8 – Efficiency vs. Input Voltage and Output Load, Room Temperature.



6.2 Regulation vs. Load (40 V)

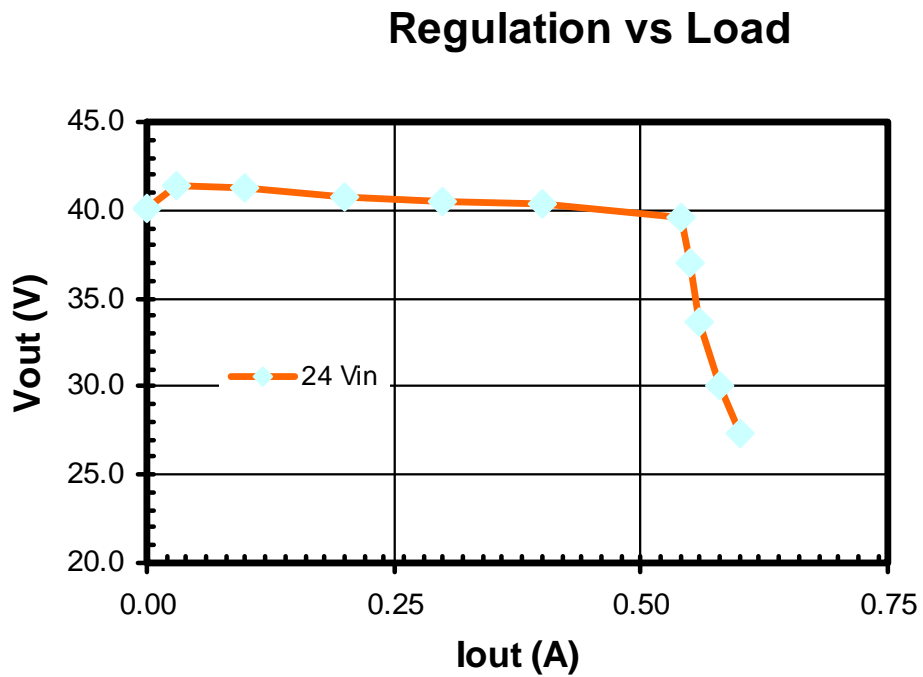

Figure 9 – Board 1 (40 V), Output Regulation vs. Output Load, Room Temperature.



6.3 Regulation vs. Load (60 V)

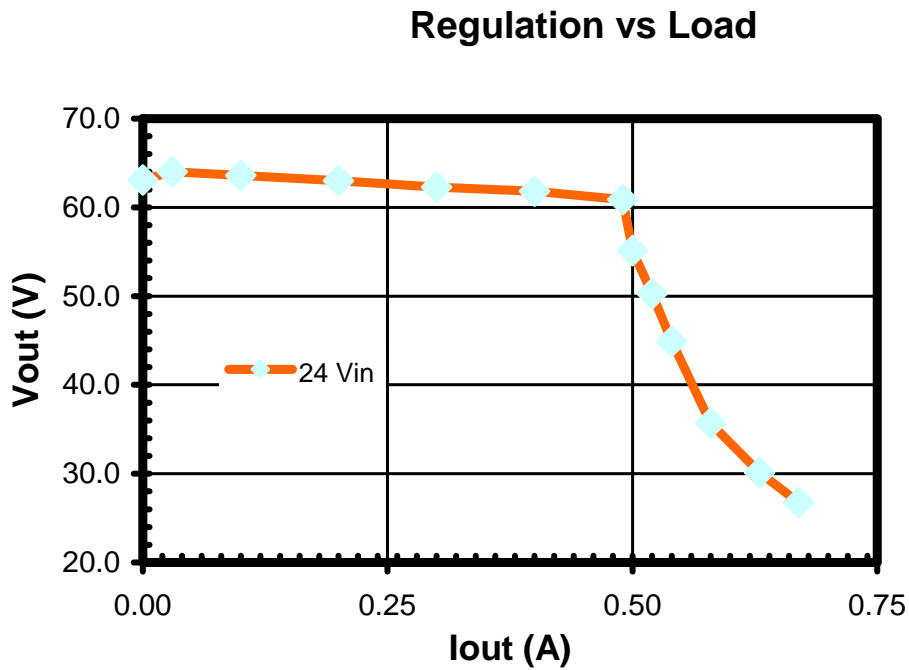

Figure 10 – Board 2 (60 V), Output Regulation vs. Output Load, Room Temperature.



7 Performance

7.1 Raw Performance Data – 60V Board

Vin (DC)	Iin (A)	Vout1 (V)	Iout1 (A)	Pin (W)	Eff (%)	Iin (A)	Pout (W)
24.12	0.031	63.1	0	0.748	0.0%	0.031	0.0
24.11	0.109	64	0.03	2.628	73.1%	0.109	1.9
24.09	0.286	63.6	0.1	6.890	92.3%	0.286	6.4
24.07	0.567	63	0.2	13.648	92.3%	0.567	12.6
24.04	0.843	62.3	0.3	20.266	92.2%	0.843	18.7
24	1.124	61.8	0.4	26.976	91.6%	1.124	24.7
23.98	1.369	60.9	0.49	32.829	90.9%	1.369	29.8
23.99	1.276	55.1	0.5	30.611	90.0%	1.276	27.6
24	1.188	50.3	0.52	28.512	91.7%	1.188	26.2
24.01	1.089	44.9	0.54	26.147	92.7%	1.089	24.2
24.02	0.941	35.7	0.58	22.603	91.6%	0.941	20.7
24.03	0.859	30.13	0.63	20.642	92.0%	0.859	19.0
24.04	0.804	26.73	0.67	19.328	92.7%	0.804	17.9

7.2 Raw Performance Data – 40 V Board

Vin (DC)	Iin (A)	Vout1 (V)	Iout1 (A)	Pin (W)	Eff (%)	Iin (A)	Pout (W)
24.12	0.017	40.1	0	0.410	0.0%	0.017	0.0
24.12	0.058	41.4	0.03	1.399	88.8%	0.058	1.2
24.11	0.186	41.2	0.1	4.484	91.9%	0.186	4.1
24.09	0.372	40.7	0.2	8.961	90.8%	0.372	8.1
24.08	0.544	40.5	0.3	13.100	92.8%	0.544	12.2
24.06	0.727	40.3	0.4	17.492	92.2%	0.727	16.1
24.03	0.98	39.6	0.54	23.549	90.8%	0.980	21.4
24.04	0.93	37	0.55	22.357	91.0%	0.930	20.4
24.04	0.852	33.6	0.56	20.482	91.9%	0.852	18.8
24.05	0.794	30.1	0.58	19.096	91.4%	0.794	17.5
24.06	0.74	27.38	0.6	17.804	92.3%	0.740	16.4



8 Revision History

Date	Author	Revision	Description & changes	Reviewed
December 20, 2005	RM	1.0	Initial release	VC
July 19, 2006	PV	1.1	Minor edits to spec table	KM



For the latest updates, visit our website: www.powerint.com

Power Integrations reserves the right to make changes to its products at any time to improve reliability or manufacturability. Power Integrations does not assume any liability arising from the use of any device or circuit described herein. POWER INTEGRATIONS MAKES NO WARRANTY HEREIN AND SPECIFICALLY DISCLAIMS ALL WARRANTIES INCLUDING, WITHOUT LIMITATION, THE IMPLIED WARRANTIES OF MERCHANTABILITY, FITNESS FOR A PARTICULAR PURPOSE, AND NON-INFRINGEMENT OF THIRD PARTY RIGHTS.

PATENT INFORMATION

The products and applications illustrated herein (including transformer construction and circuits external to the products) may be covered by one or more U.S. and foreign patents, or potentially by pending U.S. and foreign patent applications assigned to Power Integrations. A complete list of Power Integrations' patents may be found at www.powerint.com. Power Integrations grants its customers a license under certain patent rights as set forth at <http://www.powerint.com/ip.htm>.

The PI Logo, **TOPSwitch**, **TinySwitch**, **LinkSwitch**, **DPA-Switch**, **EcoSmart**, **PI Expert** and **PI FACTS** are trademarks of Power Integrations, Inc. Other trademarks are property of their respective companies. ©Copyright 2005 Power Integrations, Inc.

Power Integrations Worldwide Sales Support Locations

WORLD HEADQUARTERS

5245 Hellyer Avenue
San Jose, CA 95138, USA.
Main: +1-408-414-9200
Customer Service:
Phone: +1-408-414-9665
Fax: +1-408-414-9765
e-mail: usasales@powerint.com

GERMANY

Rueckertstrasse 3
D-80336, Munich
Germany
Phone: +49-89-5527-3910
Fax: +49-89-5527-3920
e-mail: eurossales@powerint.com

JAPAN

Keihin Tatemono 1st Bldg
2-12-20
Shin-Yokohama, Kohoku-ku,
Yokohama-shi, Kanagawa ken,
Japan 222-0033
Phone: +81-45-471-1021
Fax: +81-45-471-3717
*e-mail:
japansales@powerint.com*

TAIWAN

5F, No. 318, Nei Hu Rd., Sec. 1
Nei Hu Dist.
Taipei, Taiwan 114, R.O.C.
Phone: +886-2-2659-4570
Fax: +886-2-2659-4550
*e-mail:
taiwansales@powerint.com*

CHINA (SHANGHAI)

Rm 807-808A,
Pacheer Commercial Centre,
555 Nanjing Rd. West
Shanghai, P.R.C. 200041
Phone: +86-21-6215-5548
Fax: +86-21-6215-2468
e-mail: chinasales@powerint.com

INDIA

261/A, Ground Floor
7th Main, 17th Cross,
Sadashivanagar
Bangalore, India 560080
Phone: +91-80-5113-8020
Fax: +91-80-5113-8023
e-mail: indiasales@powerint.com

KOREA

RM 602, 6FL
Korea City Air Terminal B/D,
159-6
Samsung-Dong, Kangnam-Gu,
Seoul, 135-728, Korea
Phone: +82-2-2016-6610
Fax: +82-2-2016-6630
*e-mail:
koreasales@powerint.com*

EUROPE HQ

1st Floor, St. James's House
East Street, Farnham
Surrey, GU9 7TJ
United Kingdom
Phone: +44 (0) 1252-730-140
Fax: +44 (0) 1252-727-689
e-mail: eurossales@powerint.com

CHINA (SHENZHEN)

Room 2206-2207, Block A,
Elec. Sci. Tech. Bldg.
2070 Shennan Zhong Rd.
Shenzhen, Guangdong,
China, 518031
Phone: +86-755-8379-3243
Fax: +86-755-8379-5828
e-mail: chinasales@powerint.com

ITALY

Via Vittorio Veneto 12
20091 Bresso MI
Italy
Phone: +39-028-928-6000
Fax: +39-028-928-6009
e-mail: eurossales@powerint.com

SINGAPORE

51 Newton Road,
#15-08/10 Goldhill Plaza,
Singapore, 308900
Phone: +65-6358-2160
Fax: +65-6358-2015
*e-mail:
singaporesales@powerint.com*

APPLICATIONS HOTLINE

World Wide +1-408-414-9660

APPLICATIONS FAX

World Wide +1-408-414-9760

