

Application Note AN-59

LYTSwitch™-4 Family



Design Guide

Introduction

The LYTSwitch-4 family of devices are highly integrated monolithic switching ICs optimized to provide an isolated, dimmable (NEMA complaint), high power factor (PF), constant current driver for LED lighting applications at output powers of up to 78 W applications. LYTSwitch-4 devices reduce circuit complexity by integrating the power MOSFET and controller plus eliminating the optocoupler and all secondary side feedback components.

The LYTSwitch-4 devices are divided into two families as shown in Table 1, that is LYT4x1x for low-line and LYT4x2x for high-line applications each having a selection of dimmable (LYT43xx) and non-dimmable (LYT42xx) parts.

Part Number	Input Voltage Range	TRIAC Dimmable
LYT4211-LYT4218	85-132 VAC	No
LYT4311-LYT4318	85-132 VAC	Yes
LYT4221-LYT4228	160-300 VAC	No
LYT4321-LYT4328	160-300 VAC	Yes

Table 1. Device Part Number Selection.

Each member of the family has a high-voltage power MOSFET and its controller integrated onto the same die. The continuous conduction mode (CCM), variable duty cycle, constant frequency operation provides both high power factor (>0.9), compliance to IEC 6100-3-2 Class C and D harmonic current limits, high efficiency and reduced EMI filtering requirements. Primary-side switching current is internally sensed eliminating external current

sense resistors. Internal start-up bias current is drawn from a high-voltage current source connected to the DRAIN pin, eliminating the need for external start-up components. The internal oscillator is frequency modulated (jitter) to reduce EMI. In addition, the ICs have integrated functions that provide system-level protection. The auto-restart function limits dissipation in the device, the transformer and the output diode during overload, output short-circuit and open-loop conditions, while the auto-recovering hysteretic thermal shutdown function disables MOSFET switching during a thermal fault.

Basic Circuit Configuration

The circuit in Figure 1 shows the basic configuration of a standard AC TRIAC dimmable LED driver using LYT4317E. The circuit uses the flyback topology and with the high level integration of LYTSwitch-4 device, far fewer design issues are left to be addressed externally, resulting in one common circuit configuration for all output specifications. For example, different output power levels may require different values for some circuit components, but the circuit configuration stays unchanged.

Scope

This application note is intended for engineers designing an isolated AC-DC LED driver using the LYTSwitch-4 family of devices. It provides guidelines to enable an engineer to quickly select key components and also complete a suitable transformer design. To simplify the task, this application note refers directly to the PIXIs design spreadsheet that is part of the PI Expert™ design software suite.

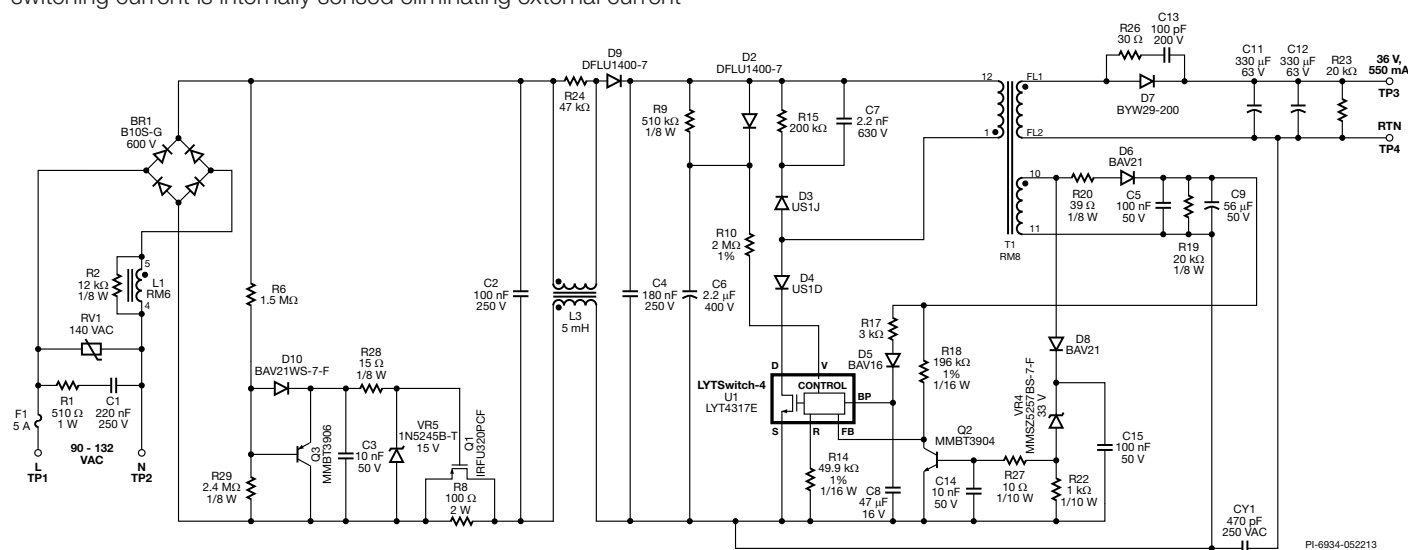

Figure 1. Typical Circuit Example (DER-350) for a 25 W Dimmable LED Driver using a LYTSwitch-4 Device.

In addition to this application note the reader may also find the product Reference Design Kits (RDKs) useful. These contain a prototype board, a link to an engineering report that contains complete design information and test data and product samples. Further details on downloading PI Expert, RDKs and updates to this document can be found at Power Integrations' website www.powerint.com.

Quick Start

Readers who want to start immediately can use the following information to quickly design the transformer and select the components for a first prototype. Only the information described below needs to be entered into the PIXIs spreadsheet, other parameters will be automatically selected based on a typical design. References to spreadsheet cell locations are provided in square brackets [cell reference].

- Select either TRIAC dimming (YES) or non-dimming/PMW dimming (NO) configuration [B3]. For LYTSwitch-4 (LYT-4X1X) Low Line Family selecting TRIAC dimming the value of the R pin resistor (R14 in Figure 1) is 49.9 k Ω , 1% and for non-dimming 24.9 k Ω , 1%. While for the LYTSwitch-4 (LYT-4X2X) High Line Family the value of the R pin resistor is 24.9 k Ω , 1% be it for TRIAC dimming or non-dimming configuration.
- Enter AC input voltage range $V_{AC,MIN}$, $V_{AC,MAX}$ and minimum line frequency f_L [B4, B5, B6] based on Table 1.
- Enter nominal output (LED string) voltage V_O [B7], maximum output voltage $V_{O(MAX)}$ [B8] and minimum output voltage $V_{O(MIN)}$ [B9]. Ratio of $V_{O(MAX)}/V_{O(MIN)}$ should be less than ≤ 1.66 ($V_O \pm 25\%$).
- Enter the nominal output (LED string) current I_O [B11].
- Enter efficiency estimate η [B13] based on Table 3.
- Select LYTSwitch-4 device from the drop down list or enter directly [B18]. Use Table 4 for guidance based on input voltage and output power. Where a choice between two devices exists it is recommended to select the larger device and operate in reduced current limit mode for higher efficiency.
- Select the device Current Limit Mode operating mode that will be used. Enter [B20] either reduced (RED) or full (FULL). Reduced is recommended for maximum efficiency (smallest enclosure size and heat sinking) e.g. A19 retro-fit lamp applications.
- Enter V_D [B32], the forward voltage of the expected output diode. Use 0.5 V for Schottky barrier types and 0.8 V for PN types.
- Enter the desired core type from the drop down menu or directly [B46]. Entering Auto will select a core size suitable for the specified output power. If the desired core is not listed, then you may enter a core's characteristics A_E , L_E and A_L ([B48], [B49], [B50]). Enter in the bobbin width BW [B51].
- If margin tape is required (non-triple insulated wire, isolated output design), then enter the margin tape width in [B52]. Note: This will reduce the winding width by two times the margin tape width entered. For 230 VAC applications a value of 3.2 mm is typical and for 100 VAC / 115 VAC use 2 mm. In practice triple insulated wire is used in most isolated designs to minimize the size of the transformer due to limited space.
- Verify that the core's gap L_G [D79], the wire gauge AWG [D84] and the primary's winding current density CMA [D86] are

within acceptable limits. Follow the guidance provided in column F to achieve this.

- Once all warning and errors have been addressed click on the Transformer Parameter and Transformer Construction tabs to obtain detailed transformer specification and construction details. These can be used to either construct the transformer in house or send to an external magnetic vendor.
- Using PIV_S [D102] and I_O [B11] determine the proper output rectifier. Select a diode with a voltage (V_{RRM}) rating $>PIV_S$ and current rating $>I_O$ with a recommendation of $\geq 2 \times I_O$ for higher efficiency.
- The value of I_{RIPPLE} [D93] and $V_{O(MAX)}$ [D8] should be used to select the appropriate output capacitor. The selected capacitor should have a ripple current rating $>I_{RIPPLE}$ and voltage rating $>V_{O(MAX)}$.
- The value of the VOLTAGE MONITOR pin resistor (R_V) and if used the second lower VOLTAGE MONITOR pin resistor (R_{V2}) are provided in cells [D27] and [D28]. A value for $R_{V2} > 10 M\Omega$ indicates that it is not required.
- The value of the REFERENCE pin resistor (R14 in Figure 1) programs TRIAC dimming or non-dimming. The value for the feedback resistor (R_{FB1}) is given in cell [D30]. This is the resistor connected from the FEEDBACK pin to the bias supply and is used to sense the output voltage.
- Using I_{AVG} [E64] determine the required input filter inductor current rating.
- If necessary, the output current can be fine-tuned. After the first prototype is built and running, enter the output current in cells [B112] and [B113] at line voltages [B110] and [B111], new values for R_{V1} and R_{V2} are then calculated [B114], [B115]. With these values adjusted measure and enter values for the bias voltage V_{B1} and V_{B2} [B122], [B123] and associated output current I_{O1} and I_{O2} [D124], [D125]. An adjusted value for $R_{FB1(NEW)}$ and $R_{FB2(NEW)}$ [D126], [D127] (if needed) will be calculated.

Step-by-Step Design Procedure

Step 1. Enter Application Variables (Figure 4): Dimming, $V_{AC,MIN}$, $V_{AC,MAX}$, f_L , V_O , $V_{O(MAX)}$, $V_{O(MIN)}$, V_{OVP} , I_O , η , V_B

Dimming Required [B3]: YES, NO

Enter YES, if the driver is to be used with TRIAC phase angle based AC dimmers else enter NO (including for PWM dimming). This input determines the configuration of the VOLTAGE MONITOR pin and REFERENCE pin resistors. The value of the REFERENCE pin resistor configures the part into either (TRIAC) dimming mode or normal mode. Dimming mode reduces the amount of input line voltage compensation to improve the dimming range obtained with TRIAC based phase angle dimmers. In this mode the output current regulation is maintained within narrow limits only over a single input voltage range (e.g. 85 VAC - 132 VAC or 185 VAC - 265 VAC). Below this input range the output current will reduce (equivalent to reduced conduction angle of a TRIAC dimmer) and above this range the output current will increase.

The normal (non-dimming) mode provides input line voltage compensation that maintains output current regulation within narrow limits across input voltage ranges (e.g. 85 VAC - 132 VAC or 185 VAC - 265 VAC). This mode does not prevent the device

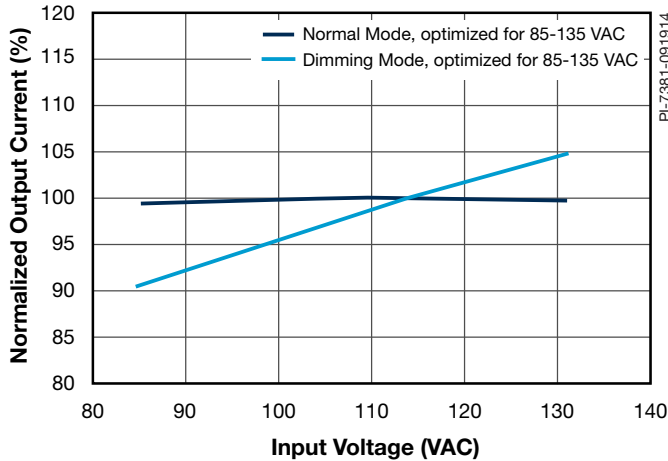

Figure 2. Comparison of Output Current Regulation in Dimming and Normal Modes Versus Line Voltage. Typical Single Input Voltage Operating Ranges Shown Above (85-132 VAC).

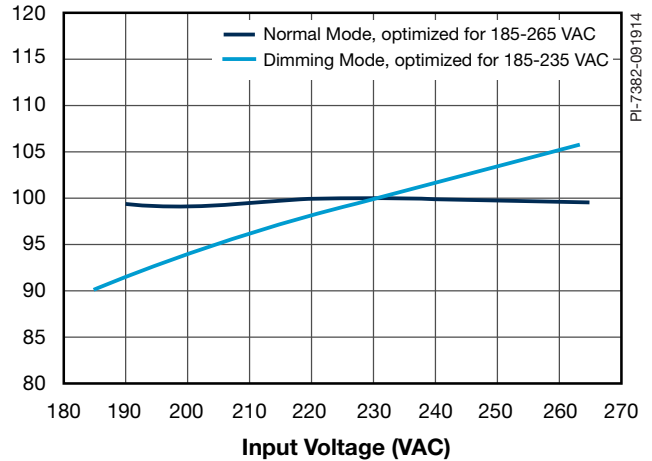

Figure 3. Comparison of Output Current Regulation in Dimming and Normal Modes Versus Line Voltage. Typical Single Input Voltage Operating Ranges Shown Above (185-265 VAC).

from being used with AC phase dimmers however dimming range is reduced. Figures 2 and 3 show a summary of the expected output current regulation performance versus line voltage between the two operating modes.

Input Voltage and Line Frequency,

VAC_{MIN} [B4], VAC_{MAX} [B4], f_L

Select the input voltage and line frequency from Table 2. For TRIAC dimming designs a single input voltage specification is preferred as this allows greater design optimization. For example a single input 100 VAC / 115 VAC versus a universal input design requires lower voltage components, smaller safety spacing requirements and reduced TRIAC bleeder current. This allows the design to offer smaller size, lower cost, broader TRIAC compatibility and higher overall efficiency. For non-TRIAC dimming specifications there is no efficiency benefit for a single input line voltage specification. This is due to the elimination of the damper and bleeder networks in non-dimming designs.

However the component rating, size and safety spacing benefits still apply for a single low-line vs. a universal input specification.

Nominal Output Voltage [B7], V_O (V)

Enter the nominal output voltage of the LED string to be driven. LYTSwitch-4 based drivers are optimized to cover an output voltage range of 2:1. Higher output voltages result in higher overall efficiency due to a reduction in secondary diode and winding losses. Figure 5 shows an example of this effect for a non-TRIAC dimmable 14 W output, 100 VAC / 115 VAC input design using an RM8 core size for the transformer.

For a TRIAC dimmable design the values would reduce by ~3% due to the losses in the TRIAC compatibility damper and bleeder circuit blocks.

Maximum Output Voltage [B8], V_{O(MAX)} (V)

Enter the maximum LED string voltage to be driven including tolerance. If left blank a value of 1.1 × V_O is assumed.

ENTER APPLICATION VARIABLES				Design Title
Dimming required	YES	YES		Select 'YES' option if dimming is required. Otherwise select 'NO'.
VACMIN	85	85	V	Minimum AC Input Voltage
VACMAX	132	132	V	Maximum AC input voltage
fL		60	Hz	AC Mains Frequency
VO	36.00	36.00	V	Typical output voltage of LED string at full load
VO_MAX		39.60	V	Maximum expected LED string Voltage.
VO_MIN		32.40	V	Minimum expected LED string Voltage.
V_OVP		43.56	V	Overvoltage protection setpoint
IO	0.700	0.700	A	Typical full load LED current
PO		25.2	W	Output Power
n	0.88	0.88		Estimated efficiency of operation
VB		25.00	V	Bias Voltage

Figure 4. Application Variables Section of the Design Spreadsheet.

Nominal Input Voltage (VAC)	Minimum Line Voltage (VAC _{MIN})	Maximum Line Voltage (VAC _{MAX})	Nominal Line Frequency (f _{L(NOM)} (Hz))	Notes
100/115	85	132	50	VAC _{MIN} , f _{L(NOM)} : Japan VAC _{MAX} : USA
230/240	195	264	50	Europe/rest of world
208/277	177	320	60	Lighting in commercial buildings in USA, (208 VAC phase to phase)

Table 2. Standard Worldwide Input Line Voltages and Line Frequencies.

Nominal Output Power (W)	Efficiency Estimate (%)			
	TRIAC Dimming		Non-TRIAC Dimming	
	V _o ≤ 12 V	V _o > 12 V	V _o ≤ 12 V	V _o > 12 V
≤ 3	45	55	55	65
3-6	65	77	78	82
6-10	76	78	80	83
10-20	82	85	85	88
> 20	83	86	86	89

Table 3. Initial Efficiency Estimates for a New Design.

Output Power Table

Product	Minimum Output Power ³	Maximum Output Power ⁴	Product	Minimum Output Power ³	Maximum Output Power ⁴
LYT4x11E	2.5 W	12 W	LYT4x21E	6 W	12 W
LYT4x12E	2.5 W	15 W	LYT4x22E	6 W	15 W
LYT4x13E	3.8 W	18 W	LYT4x23E	8 W	18 W
LYT4x14E	4.5 W	22 W	LYT4x24E	9 W	22 W
LYT4x15E	5.5 W	25 W	LYT4x25E	11 W	25 W
LYT4x16E	6.8 W	35 W	LYT4x26E	14 W	35 W
LYT4x17E	8.0 W	50 W	LYT4x27E	19 W	50 W
LYT4x18E	18 W	78 W	LYT4x28E	33 W	78 W

Figure 4. Device Family Power Table for Initial Device Selection.

Minimum Output Voltage [B9], V_{O(MIN)} (V)

Enter the minimum LED string voltage. If left blank a value of 0.9 × V_o is assumed.

Nominal Output Current [B11], I_o (A)

Enter the nominal output current the LED string is to be driven with.

Nominal Output Power [D12], P_o (W)

The calculated nominal output power.

Power Supply Efficiency [B13], η

Enter the estimated efficiency of the complete power supply measured at the output terminals under full load conditions and

worst-case line (generally lowest input voltage). Initial values are provided in Table 3. Measure the efficiency of the first prototype board at nominal output power and both VAC_{MIN} and VAC_{MAX} if the measured efficiency is lower than estimated then enter the measured value and refine the transformer design.

Bias Voltage, V_B (V)

This entry determines the output voltage from the bias winding. For non TRIAC dimming designs a value of 20 V is recommended and 25 V where TRIAC dimming is required. The higher voltage ensures adequate voltage to supply the IC at the minimum LED string voltage and with a TRIAC dimmer at minimum conduction angle (<30 degrees).

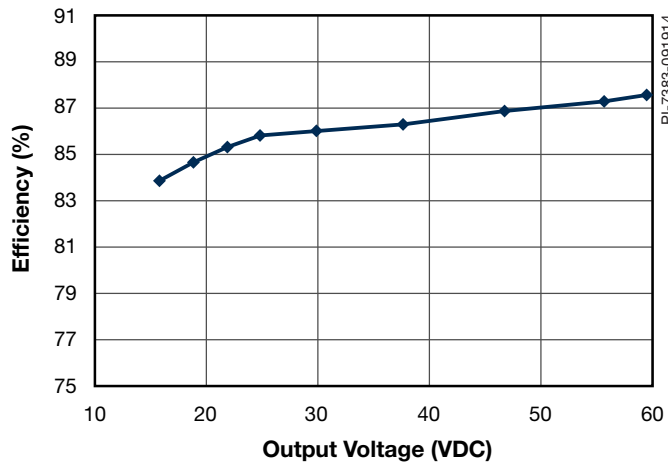

Figure 5. Effect of Output Voltage on Efficiency, Measured on 9 Isolated Flyback Designs (15W, RM7 Core Size, Non-dimming Design Measured at 230 VAC).

The current limit mode selection defines the value of the BYPASS pin capacitor: 47 μF for reduced and 4.7 μF for full current limit mode.

The recommended maximum operating device temperature under worst-case conditions (input line and external product ambient temperature) is 100 °C for the tightest output current distribution over production, and 115 °C to provide adequate design margin and ensure thermal shutdown is not triggered.

Upper V Pin Resistor Value [B27], R_V , M Ω (Entry Optional)

If left blank a default value of 2 M Ω is used for both dimming and non-dimming designs. In conjunction with the lower VOLTAGE MONITOR pin resistor (R_{V2}) these values provide the best output current regulation for non-dimming and without R_{V2} , the widest dimming range in dimmable applications.

In Figure 1 R_V is R10, a 1% or better tolerance should be used to obtain the narrowest output current tolerance. The voltage

ENTER LYTSwitch-4 VARIABLES				
LYTSwitch-4	LYT4X17	LYT4317		Selected LYTSwitch-4. Part number will change based on dimming/non-dimming application.
Current Limit Mode	RED	RED		Select "RED" for reduced Current Limit mode or "FULL" for Full current limit mode
ILIMITMIN		2.35	A	Minimum current limit
ILIMITMAX		2.73	A	Maximum current limit
fS		132000	Hz	Switching Frequency
fSmin		124000	Hz	Minimum Switching Frequency
fSmax		140000	Hz	Maximum Switching Frequency
IV		79.8	μA	V pin current
RV		2.00	M-ohms	Upper V pin resistor
RV2		1.E+12	M-ohms	Lower V pin resistor
IFB	165.00	165.00	μA	FB pin current (85 μA < IFB < 210 μA)
RFB1		133.3	k-ohms	FB pin resistor
VDS		10.00	V	LYTSwitch on-state Drain to Source Voltage
VD		0.50	V	Output Winding Diode Forward Voltage Drop (0.5 V for Schottky and 0.8 V for PN diode)
VDB		0.70	V	Bias Winding Diode Forward Voltage Drop

Figure 6. LYTSwitch-4 Variables Section of the Design Spreadsheet.

Step 2. Enter LYTSwitch-4 Variables (Device Size, Current Limit Mode, R Pin Resistor, V Pin Resistor (R_V), FEEDBACK Pin Current I_{FB} , Drain to Source Voltage (V_{DS}), Output Forward Voltage (V_D), and Bias Diode Forward Voltage (V_{DB}))

Device Selection [B18] and Current Limit Mode [B19]

Select a LYTSwitch-4 device based on the output power using Table 4 for guidance.

For thermally challenging designs, e.g. incandescent lamp replacement, where either the ambient temperature local to the LYTSwitch-4 device is high and/or there is minimal space for heat sinking use the minimum output power column and select the reduced current limit mode by entering RED (Reduced).

For open frame designs or designs where space is available for heat sinking then select from the maximum output power column and select the full current limit mode by entering FULL.

stress equals the peak of the AC line voltage so an equivalent rating of 250 V is recommended for low-line input.

Care should be taken when placing the VOLTAGE MONITOR pin resistor(s) on the PCB to avoid noise coupling from the DRAIN node. In designs where encapsulation (potting) is used leakage currents and noise coupling may cause changes in VOLTAGE MONITOR pin current post potting. This effect can be minimized again by careful layout and/or the addition of a 100 nF capacitor and parallel 5.6 V Zener diode connected from the VOLTAGE MONITOR pin to SOURCE pin. Place the capacitor as close to the device as possible and return directly to the SOURCE pin rather than via any other source connected nodes.

REFERENCE Pin Resistor Value

This component is not included in the design spreadsheet as it is selected from one of two values. The value of the REFERENCE pin resistor is determined based on whether TRIAC dimming is

required. For TRIAC dimming select a value 49.9 kΩ and for non (TRIAC) dimming 24.9 kΩ. When configured for dimming the jitter is disabled in deep dimming and line compensation of output current reduced which increases the dimming range. In the non-dimming configuration the line compensation of the output current maintain tight regulation across the input voltage range.

FEEDBACK Pin Current, I_{FB} , μA (Optional)

If left blank a calculated value is used. The calculation depends on the value of the REFERENCE pin resistor (dimming or non-dimming configuration) and the value of V_{OR} . I_{FB} is used to

regulate the output current and must be in the range of 85 μA to 210 μA under normal operating conditions including variation in the LED string voltage. Therefore to maximize the allowable output voltage variation and give smallest output current variation a value of 150 μA is ideal allowing an LED string voltage variation of up to 2:1, ($V_{O(MAX)}:V_{O(MIN)}$). In practice most designs have a smaller output voltage variation and any value in the range 110 μA to 190 μA is acceptable.

Feedback Resistor Value, R_{FB1} , kΩ

This is the calculated value for the resistor connected to the

KEY DESIGN PARAMETERS				
KP	0.87	0.87		Ripple to Peak Current Ratio (For PF > 0.9, 0.4 < KP < 0.9)
LP		373	uH	Primary Inductance
VOR	102.00	102.00	V	Reflected Output Voltage.
Expected IO (average)		0.721	A	Expected Average Output Current
KP_VNOM		0.83		Expected ripple current ratio at VACNOM (115VAC)
TON_MIN		2.02	us	Minimum on time at maximum AC input voltage
PCLAMP		0.21	W	Estimated dissipation in primary clamp

Figure 7. Key Design Variables Section of the Design Spreadsheet.

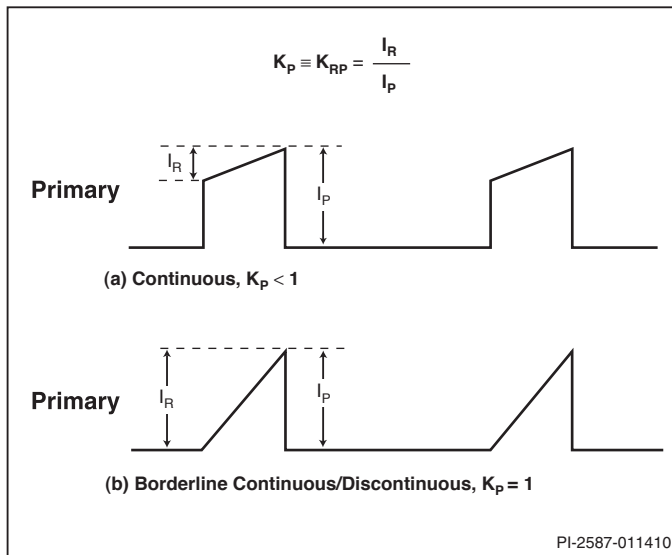

Figure 8. Continuous Conduction Mode Current Waveform ($K_p < 1$) Showing Definition of K_p .

FEEDBACK pin from the bias winding output to give the value of I_{FB} at the nominal output voltage (V_o).

LYTSwitch-4 Device ON-State Drain to Source Voltage, V_{DS} , V (Optional)

This parameter is the average ON-state voltage developed across the DRAIN and SOURCE pins of LYTSwitch-4. By default, if the grey override cell is left empty, a value of 10 V is assumed. Use the default value if no better data is available.

Output Diode Forward Voltage Drop, V_D , V

Enter the average forward drop for the output diode used. A value of 0.5 V is recommended for a Schottky diode and 0.8 V for a PN Ultrafast diode.

Bias Winding Forward Voltage Drop, V_D , V

Enter the average forward drop for the bias winding output diode. Use 0.7 V for a PN diode.

Input Current Harmonic Analysis				
Harmonic	Max Current	Limit		N/A
1st Harmonic	277.78	N/A	mA	N/A
3rd Harmonic	15.65	N/A	mA	N/A
5th Harmonic	6.74	N/A	mA	N/A
7th Harmonic	4.13	N/A	mA	N/A
9th Harmonic	2.68	N/A	mA	N/A
11th Harmonic	1.65	N/A	mA	N/A
13th Harmonic	1.00	N/A	mA	N/A
15th Harmonic	0.69	N/A	mA	N/A
THD	17.6	%		N/A

Figure 9. Input Current Harmonic Analysis (THD Estimate) of the Design Spreadsheet Section.

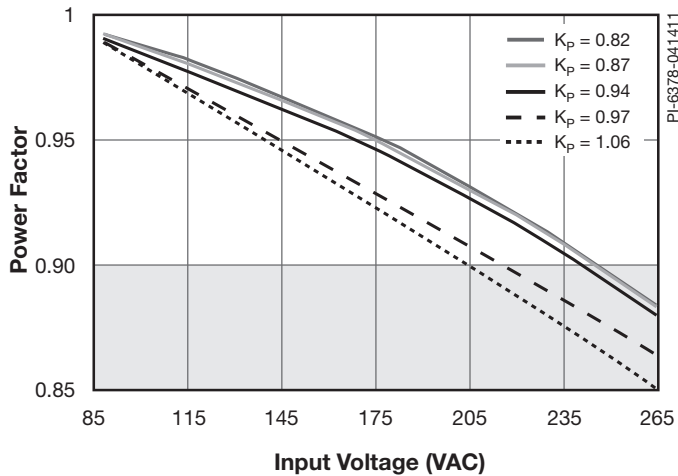

Figure 10. Illustration of the Impact of the Design Parameter K_p on PF.

Step 3. Enter Key Design Variables: Ripple to Peak Current Ratio (K_p), Reflected Output Voltage (V_{OR})

Ripple to Peak Current Ratio (K_p)

Figure 10 shows $K_p < 1$, indicating continuous conduction mode, K_p is the ratio of ripple to peak primary current. LYTSwitch-4 devices require that the design operates in continuous conduction mode to achieve high power factor (PF) and low Total Harmonic Distortions (THD). The recommended range for the value of K_p is $0.4 \leq K_p \leq 0.9$. For reference a K_p value of < 0.7 gives a PF > 0.95 and THD $< 20\%$ while a design with a K_p of 0.9 gives PF > 0.9 with THD $< 30\%$. At lower power levels higher K_p values may be used to trade smaller transformer core size against lower

PF and efficiency. By default a value of 0.8 for $P_O \leq 25$ W and 0.4 for $P_O > 25$ W is used. For reference Figure 10 shows the measured effect of K_p on PF in a low-line input, 28 V, 14 W output design.

The goal in selecting the value of K_p is to use the highest value that still meets the PF, THD and harmonic current specifications. Higher values of K_p minimize the transformer size and number of turns. For designs less than 25 W input power start with a K_p value of 1.1. This typically gives PF < 0.9 , THD $< 30\%$ and class C (class D limits) compliance. If performance is unacceptable then iterate the design with a lower value for K_p . For designs above 25 W and where class C compliance uses class C limits is required start with a K_p value of 0.5. If class C harmonics compliance is not required then use a K_p value of 1.1. Odd input current harmonics and total harmonics distortion (THD) are automatically calculated in the spreadsheet as shown in Figure 9.

Reflected Output Voltage, V_{OR} (V)

This parameter is the secondary winding voltage during diode conduction, reflected back to the primary through the turns ratio of the transformer. Effectively V_{OR} is the parameter that sets the turns ratio of the transformer. The default value is 80 V; however the target range for V_{OR} is between 65 V and 135 V, provided that no warnings in the spreadsheet are triggered. For design optimization purposes, the following trade-offs should be considered:

1. Higher values of V_{OR} (with low values of K_p) typically requires a larger core size due to the increased primary inductance and number of primary turns.

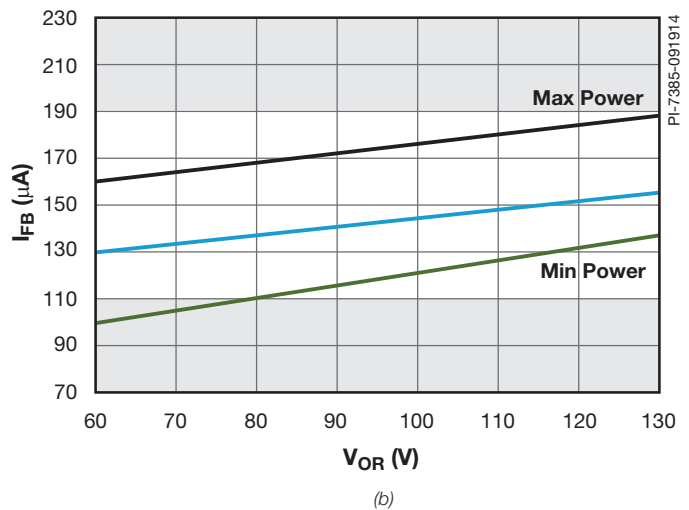
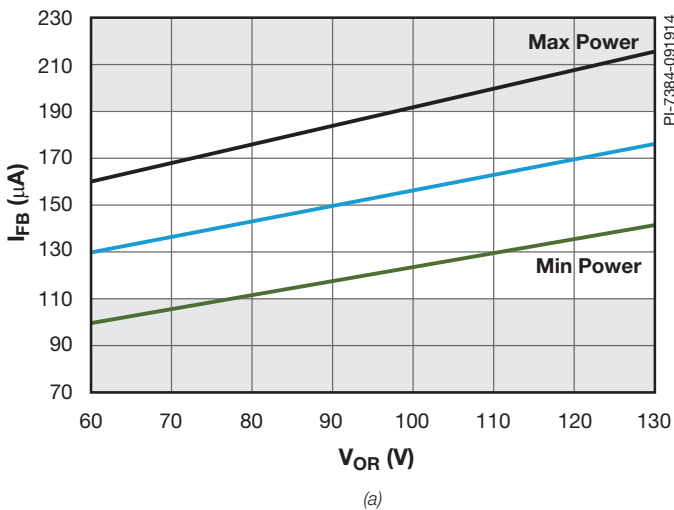

Figure 11. V_{OR} Selection Curves for Designs using a 2 MΩ (100/115 VAC) (a) and 4 MΩ (230 VAC) (b) VOLTAGE MONITOR Pin Resistor Values.

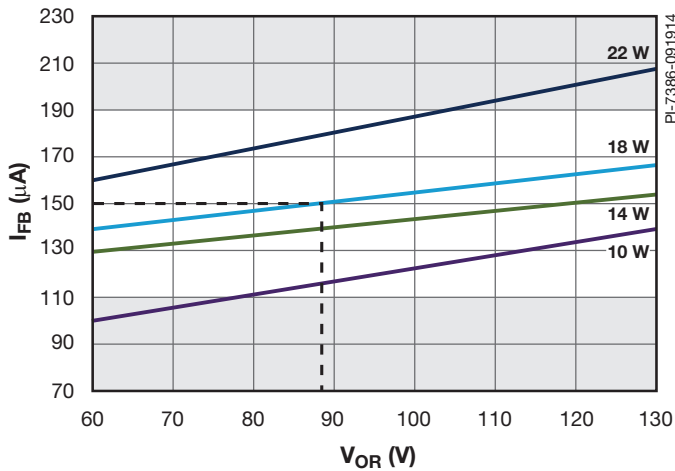

Figure 12. Example of Selecting V_{OR} for a Low Line Input, 14 W Design using LYT4324.

- Higher values of V_{OR} reduces the output diode voltage stress. For $V_{O(MAX)}$ values below ~18 V this allows a Schottky output diode to be selected for lower losses and higher efficiency.
- Higher values of V_{OR} reduces the maximum power capability of a given LYTSwitch-4 device.

the upper and lower lines with the minimum and maximum power levels from the device data sheet power table. For the LYT4324E the maximum power table value in a high-line only design is 22 W. The minimum is 10 W. Therefore the middle line can be calculated as 16 W. Draw a parallel line between the existing lines on the chart representing the output power required, 17.5 W in this case. Then find the intersection between the 18 W power line and desired value of I_{FB} , with a value of 150 μ A being ideal. In this example the intersection indicated a value for V_{OR} of 88 V.

Primary Inductance, L_p (μ H)

This is the calculated nominal value of primary inductance for the transformer. Designs using LYTSwitch-4 are insensitive to variations in the value of L_p in terms of output current and power delivery with the limitation being that the design maintains operation in continuous conduction mode. A tolerance of $\pm 10\%$ is typical when specifying the design to a transformer vendor.

Expected Average Output Current, Expected $I_{O(AVERAGE)}$ (A)

The calculated average output current, for a valid design this should match specified output current I_o .

Ripple to Peak Current Ratio at $V_{AC(MAX)}$, ($K_{P_{VAC(MAX)}}$)

This is the calculated value of K_p at the peak of the maximum

ENTER TRANSFORMER CORE/CONSTRUCTION VARIABLES				
Core Type	RM8/I		RM8/I	Core Size
Custom Core				Enter custom core part number
AE		0.63	cm^2	Core Effective Cross Sectional Area
LE		3.84	cm	Core Effective Path Length
AL		3000	nH/T^2	Ungapped Core Effective Inductance
BW		8.6	mm	Bobbin Physical Winding Width
M		0.00	mm	Safety Margin Width (Half the Primary to Secondary Creepage Distance)
L	2			Number of Primary Layers
NS	16			Number of Secondary Turns

Figure 13. Transformer Variables Section of the Design Spreadsheet.

Optimal selection of the V_{OR} value depends on the specific application and is based on a compromise between the factors mentioned above. Figure 11 (a) & (b) may be used as a guide and provides an initial value based on the value of the VOLTAGE MONITOR pin resistor and the output power. The upper line represents the maximum and lower line the minimum output power from the selected LYTSwitch-4 device as shown in the data sheet power table. The middle line is the mid point between these two power levels. The unshaded region is the recommended range for the feedback current I_{FB} .

An example of using these selection curves for a 18 W, low-line, LYT4324E design is shown in Figure 12. Start by labeling

input voltage ($V_{AC(MAX)}$). This value should remain below 1.12 to ensure a PF of <0.9 at nominal AC input.

Minimum On Time at $V_{AC(MAX)}$, $t_{ON(MIN)}$ (μ s)

This is the calculated minimum on time of the internal MOSFET at the peak of $V_{AC(MAX)}$. This value is should be greater than the minimum device on time of 1.5 μ s.

Clamp Dissipation, P_{CLAMP} (W)

This is the calculated dissipation in the primary clamp. The calculation includes the effect of the variation in instantaneous dissipation over each AC half-cycle.

Step 4 – Select Transformer Core and Bobbin Based on Output Power and Enter A_E , L_E , A_L , BW , M , L , N_S

Core effective cross-sectional area, A_E (cm²)
 Core effective path length, L_E (cm)
 Core ungapped effective inductance, A_L (nH/turn²),
 Bobbin width, BW (mm)
 Tape margin width equal to half the total margin, M (mm)
 Primary Layers, L
 Secondary Turns, N_S

Core Type

If the core type cell is left as the default of Auto, the spreadsheet will default to the smallest commonly available core suitable for the output power specified. The entire list of cores available can be selected from the drop down list in the tool bar of the PIXIs design software.

The grey override cells can be used to enter the core and bobbin parameters directly. This is useful if a core is selected that is not on the list, or the specified core or bobbin information differs from that referenced by the spreadsheet.

Note some core and bobbin types may not meet safety spacing requirements (e.g. RM or smaller EE sizes). In these cases it is common to use a triple insulated secondary winding terminated as flying leads (rather than to the bobbin pins). This allows safety creepage and clearance distances to be met and saves PCB board area by eliminating the need for a bobbin with increased spacing.

Safety Margin, M (mm)

For designs that require safety isolation between primary and secondary but do not use triple-insulated wire, the width of the safety margin to be used on each side of the bobbin should be entered here. For universal input designs, a total margin of 6.4 mm would be required, and a value of 3.2 mm would be entered into the spreadsheet. For low-line only input designs (100/115/127 VAC) a total margin of 4 mm would be required and 2 mm entered into the spreadsheet. For vertical bobbins

the margin may not be symmetrical. However, if a total margin of 6.2 mm were required, then 3.1 mm would still be entered even if the physical margin were only on one side of the bobbin.

For designs using triple insulated wire, it may still be necessary to enter a small margin in order to meet the required safety creepage distances.

Many bobbins exist for any core size and each will have different mechanical spacing. Refer to the bobbin data sheet or seek guidance from your safety expert or transformer vendor to determine what specific margin is required.

As the margin reduces the available area for the windings, the margin format described above may not be suitable for small core sizes. If after entering the margin, more than 3 primary layers (L) are required, it is suggested that either a larger core be selected or switch to a zero margin design approach using triple insulated wire.

Primary Layers, L

Primary layers should be in the range of $1 < L < 3$, with a default value of 3. This provides a good compromise between winding losses and leakage inductance for a transformer core size appropriate for the output power. Three layers also results in lower capacitance hence improving efficiency, especially at higher input voltages. The lower limit on the value for L is set by the primary winding current density limits (circular mils per amp or CMA). CMA has a strong influence on the winding losses and therefore transformer temperature rise and efficiency. CMA values as low as 200 for designs <10 W scaling linearly to 600 at >75 W are good design targets for convection cooled designs. For designs where the driver will be encapsulated for thermal management a lower value of CMA may be acceptable. Whether or not an encapsulate is used verification of the winding temperatures (using non-ferrous T type thermocouples) is recommended. This is achieved by embedding a thermocouple into the transformer between two of the insulation tape layers that are present between the primary and secondary windings during construction. Most designs will fall into

TRANSFORMER PRIMARY DESIGN PARAMETERS				
LP		373	uH	Primary Inductance
LP_TOL		10		Tolerance of primary inductance
NP		45		Primary Winding Number of Turns
NB		11		Bias Winding Number of Turns
ALG		187	nH/T^2	Gapped Core Effective Inductance
BM		2013	Gauss	Maximum Flux Density at PO, VMIN (BM<3100)
BP		3619	Gauss	Peak Flux Density (BP<3700)
BAC		876	Gauss	AC Flux Density for Core Loss Curves (0.5 X Peak to Peak)
ur		1455		Relative Permeability of Ungapped Core
LG		0.40	mm	Gap Length (Lg > 0.1 mm)
BWE		17.2	mm	Effective Bobbin Width
OD		0.38	mm	Maximum Primary Wire Diameter including insulation
INS		0.06	mm	Estimated Total Insulation Thickness (= 2 * film thickness)
DIA		0.33	mm	Bare conductor diameter
AWG		28	AWG	Primary Wire Gauge (Rounded to next smaller standard AWG value)
CM		161	Cmils	Bare conductor effective area in circular mils
CMA		331	Cmils/Amp	Primary Winding Current Capacity (200 < CMA < 600)

Figure 14. Transformer Primary Design Parameters Section of the Design Spreadsheet

TRANSFORMER SECONDARY DESIGN PARAMETERS (SINGLE OUTPUT EQUIVALENT)				
Lumped parameters				
ISP		4.24	A	Peak Secondary Current
ISRMS		1.32	A	Secondary RMS Current
IRIPPLE		1.12	A	Output Capacitor RMS Ripple Current
CMS		264	Cmils	Secondary Bare Conductor minimum circular mils
AWGS		25	AWG	Secondary Wire Gauge (Rounded up to next larger standard AWG value)
DIAS		0.46	mm	Secondary Minimum Bare Conductor Diameter
ODS		0.54	mm	Secondary Maximum Outside Diameter for Triple Insulated Wire

Figure 15. Transformer Secondary Design Parameters Section on

VOLTAGE STRESS PARAMETERS				
VDRAIN		397	V	Estimated Maximum Drain Voltage assuming maximum LED string voltage (Includes Effect of Leakage Inductance)
PVVS		110	V	Output Rectifier Maximum Peak Inverse Voltage (calculated at VOVP, excludes leakage inductance spike)
PVVB		77	V	Bias Rectifier Maximum Peak Inverse Voltage (calculated at VOVP, excludes leakage inductance spike)

Figure 16. Voltage Stress Parameters Section of the Design Spreadsheet

insulation class A or class B limiting maximum winding temperatures (at maximum external ambient) to 105 °C and 130 °C respectively.

Designs with more than 3 layers are possible, but the increased leakage inductance and issues associated with the physical fit of the windings should be considered. A split primary construction may be helpful for designs where leakage inductance clamp dissipation is too high and providing there is sufficient winding window. In a sandwich construction half of the primary winding is placed on either side of the secondary (and bias) windings. Sandwich construction is recommended for all design >20 W.

Secondary Turns, N_s

If the grey override cell is left blank, the minimum number of secondary turns is calculated such that the maximum operating flux density B_M is kept below the recommended maximum of 3100 Gauss (310 mT). In general, it is not necessary to enter a number in the override cell except in designs where a lower operating flux density is desired (see the explanation of B_M limits).

Step 5 – Iterate Transformer Design / Generate Prototype

Iterate the design making sure that no warnings are displayed. Any parameters outside the recommended range of values can be corrected by following the guidance given in the right hand column. Once all warning and errors have been addressed click on the Transformer Parameter and Transformer Construction tabs to obtain detailed transformer specification and construction details. These can be used to either construct the transformer in house or send to an external magnetic vendor.

The key transformer electrical parameters are:

Primary Inductance, L_p (μH)

This is the target nominal primary inductance of the transformer.

Number of Primary Turns, N_p

This is the number of turns for the main primary winding.

Gapped Core Effective Inductance, A_{LG} (nH/T²)

Used by the transformer vendor to specify the core center leg air gap. This is the value of inductance obtained (in nH) for the number of turns placed around the core squared.

Maximum Operating Flux Density, B_M (Gauss)

A maximum value of 3100 Gauss during normal operation is recommended. This prevents core saturation during start-up or output short-circuit

Peak Flux Density, B_p (Gauss)

A maximum value of 3700 Gauss is recommended to limit the maximum flux density under start-up and output short-circuit conditions. In these cases the output voltage is low and little reset of the transformer core occurs during the MOSFET off-time. This can allow the transformer flux density to increase during the next and subsequent cycles (stair casing) until the core saturates. A value of 3700 Gauss, calculated at the maximum device current limit, together with the built-in protection features of LYTSwitch-4 devices, provides sufficient margin to prevent core saturation under start-up or output short-circuit conditions.

This calculation assumes worst-case current limit and nominal inductance values and accounts for high ambient temperatures as this reduces the saturation flux density of ferrite materials. It is important to verify that core saturation does not occur at maximum ambient temperature under start-up and overload conditions just prior to loss of regulation.

Maximum Primary Wire Diameter, OD (mm)

This is the calculated maximum wire size diameter that will allow the number of primary turns (N_p) to fit into the specified bobbin width (BW) with the specified number of layers (L).

The other factors automatically calculated by the spreadsheet include:

- Estimated total insulation thickness, INS (mm)
- Primary wire size, DIA: (mm)
- Primary wire gauge, AWG

Number of primary layers, L
 Estimated core center leg gap length: L_g : (mm)
 Number of secondary turns, N_s
 Secondary wire size, DIA_s : (mm)
 Secondary wire gauge, AWG

Step 6 – Selection of LYTSwitch-4 External Components

The schematic shown in Figure 1 shows the external components for a typical LYTSwitch-4 power supply design. Each of these is dealt with in the relevant section below.

BYPASS Pin Capacitor (C8)

The BYPASS pin is both the supply rail for the IC and sets the operating mode between reduced and full power. For reduced power mode a 47 μF capacitor should be selected and for full power a 4.7 μF capacitor based on the selection entered into the design spreadsheet. Either ceramic or electrolytic types may be used with a voltage rating of 10 V or above and tolerance plus temperature variation of less than $\pm 50\%$. Larger variation may cause the 47 μF capacitor to be incorrectly detected as a 4.7 μF value.

REFERENCE (R) Pin Resistor (R14)

This pin determines the operating mode between dimming and non-dimming operation. LYTSwitch-4 low-line family for dimming operation at 49.9 k Ω 1% part and for non-dimming operation a 24.9 k Ω 1% part should be used. While LYTSwitch-4 high-line family only 24.9 k Ω 1% part should be used be it dimming and non-dimming operation. Resistors with 1% tolerance (or better) should be used as variations in the resistor value directly impacts the supply output current and VOLTAGE MONITOR pin thresholds for line OV.

VOLTAGE MONITOR (V) Pin Resistor(s) (R_{V1} and R_{V2})

The initial value of the total resistance connected from the VOLTAGE MONITOR pin to the DC bus is provided in the design spreadsheet as parameter R_{V1} . Resistor R_{V2} is connected from the VOLTAGE MONITOR pin to SOURCE, typically only present in non-dimming designs to provide constant output current vs. line voltage. Both resistors should have 1% tolerance (or better) to provide unit to unit matching of dimming characteristics. A value for R_{V2} of $>10\text{ M}\Omega$ indicates that it is not required as its effect will be negligible. In Figure 1 R_{V1} is R10 while R_{V2} is not shown as it was not required for this design.

External Bias Current (R17, D5)

Resistor R5 provides the operating current for U1 during normal operation. The inclusion of external bias is recommended even though, with the exception of the LYT-4XX1 smallest device, LYTSwitch-4 devices can operate without any external bias. Providing an external bias reduces the device dissipation and allows operation to smaller conduction angles when used with phase angle dimmers. The design goal is to provide a current into the BP equal to $I_{CD1(MAX)}$ under worst-case conditions. Worst-case usually occurs at $V_{O(MIN)}$ and lowest output current (due to dimming).

As an initial starting value or dimming designs the value of R17 should be selected to provide approximately 5 mA into the BYPASS pin at the nominal output voltage (V_o) according to the expression,

$$R5 = \frac{V_B - V_{BP}}{3 \times I_{CD1(MAX)}}$$

where V_B is the bias voltage from the design spreadsheet and V_{BP} is the BYPASS pin voltage ($5.9 V_{TYP}$) and $I_{CD1(MAX)}$ is the IC supply current from the device data sheet. The factor of 3 provides adequate margin due to variations in the bias voltage due to LED string (output) voltage, especially the reduction in the value of V_B that occurs during dimming.

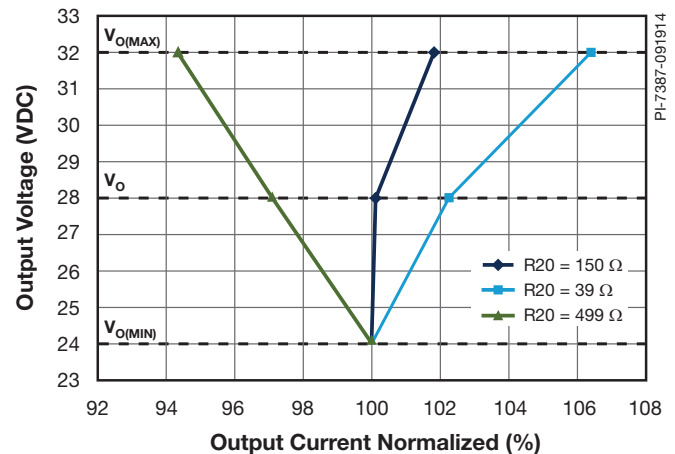

Figure 17. Effect of R20 (Bias Winding Filter Resistor) on Output Current Regulation vs LED String Voltage ($\pm 15\%$).

For non dimming designs the factor of 3 can be omitted. Dissipation in R20 is $<50\text{ mW}$ and tolerance is not critical (5% is acceptable).

Diode D5 can be any small signal diode with a voltage rating above 10 V (e.g. 1N4148, BAV16 etc). It is included to isolate the BYPASS pin from the bias winding capacitor (C9) to prevent increased start-up delay and misdetection of the value of the bypass capacitor.

Bias Diode (D6)

The primary referenced auxiliary winding on the transformer is rectified and filtered to create a bias supply that provides both the operating current into the BYPASS pin and feedback information into the FEEDBACK pin. The rectifier diode (D6) can be any fast or ultrafast recovery type with a voltage rating above the value given in the design spreadsheet (PIVB), typically $>200\text{ V}$, and current rating $>200\text{ mA}$. The 1N4936 and UF4004 or SMD equivalents are good examples.

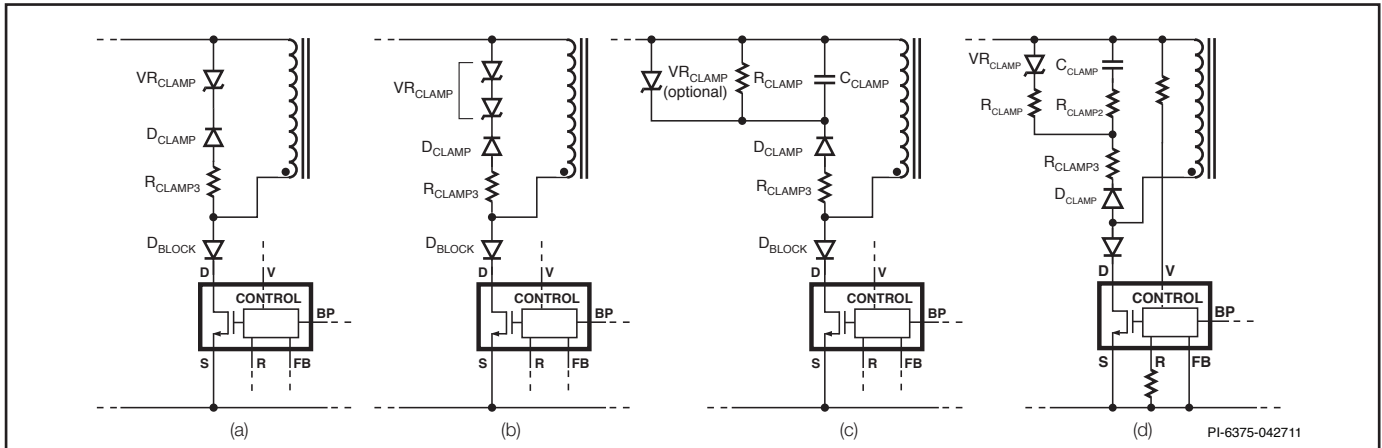

Figure 18. Recommended Clamp Configurations for LYTSwitch-4 Designs. (a) Zener Clamp, (b) Zener Clamp with Series Connected Zeners for Higher Power, (c) RCD / RCD+Z Clamp, (d) Zener Bleed Clamp.

P _o (W)	Reference Document	Configuration	D _{BLOCK}	VR _{CLAMP} (V)	D _{CLAMP}	R _{CLAMP} (kΩ)	R _{CLAMP2} (Ω)	R _{CLAMP3} (Ω)	C _{CLAMP} (pF)
7	RDR-193	A	ES1D	P6KE200	UF4007	-	-	-	-
6.9	DER-269	C	US1D	-	RS1J	100	-	100	1000
8	DER-264	C	US1D	-	RS1J	50	-	100	1000
14	RDR-195	A	UF4006	P6KE200	UF4007	-	-	-	-
15	DER-256	C	MUR120	-	FR107	82	-	100	1000
15	DER-278	A	UF4004	P6KE200	UF4007	-	-	-	-

Table 5. Example Clamp Component Values for LinkSwitch-PH Designs (applicable to LYTSwitch designs).

Filter Resistor (R20) and Capacitor (C9)

These two components form a low pass filter (pole). The corner frequency ($1/2 \times \pi \times R20 \times C9$) should be where f_L is the minimum line frequency to prevent line frequency ripple modulating the FEEDBACK pin. A corner frequency of 50 Hz results in a power factor above 0.9 at 230 VAC input. If lower power factor is acceptable the corner frequency can be increased to allow the use of a lower value capacitor. The value of R20 should be in the range of 47 Ω to 200 Ω (5% tolerance). Making the value too high results in a reduction in the bias voltage which can reduce the minimum conduction angle at which the supply will operate. Making the value too small results in the value of C9 increasing which is undesirable due to board space constraints. Capacitor C9 should have a voltage rating above the value of $V_B \times (V_{O(MAX)} / V_O)$ and can be either an electrolytic or ceramic type.

Resistor R20 also optimizes output current regulation with changes in output voltage. Figure 17 shows the effect of changing R20 over a 10:1 range. It can be seen that a value of 150 Ω in this case gave the best output current regulation as the output voltage was varied ±15%.

Bleed Resistor (R19)

This resistor provides an addition load on the bias supply to prevent the voltage from peak charging due to the effects of

transformer leaking inductance. Select the value (5% tolerance) to generate a current of ~2 mA at the bias voltage (V_B).

Feedback Resistor (R18)

For the first prototype use the value provided in the design spreadsheet (R_{FB1}). As this resistor directly impacts the output regulation it should have a 1% tolerance.

Peak Detector (D2, R9 and C6)

This network is used to provide a DC voltage from which a current is fed into the V pin of the LYTSwitch-4 device.

Diode D2 allows C6 to charge to the peak of the incoming rectified AC. Resistor R9 provides a discharge path to allow the voltage across C6 to track changes in the incoming AC. The value of C6 should be ≥ 100 nF for a PF of >0.9. Larger values (up to 1 μF) further increase the achievable PF up to 0.99. Values above 1 μF provide only incremental improvement but do provide additional filtering during differential line surges, reducing the peak drain voltage. A voltage rating of $>1.41 \times VAC_{MAX}$ is required and both film, ceramic or electrolytic types may be used. Resistor R9 should be selected such that $R9 \times C6 > 80$ ms so that the voltage across C6 is essentially constant over one AC half cycle. A voltage rating of $>1.41 \times VAC_{MAX}$ is recommended. A standard 1N4007 plastic rectifier is recommended for D1.

Step 7 – Selection of Primary Clamp Components (R15, C7 and D3)

Several different clamp configurations are shown in Figure 18. Diode D_{BLOCK} (D3 in Figure 1) prevents current flow occurring from source to drain during the period of each AC half-cycle where the rectified AC voltage is below the reflected output voltage (V_{OR}) of the design. The diode should be an ultrafast type and have a current rating above the average drain current (I_{AVG}) and voltage rating of $>1.2 \times V_{OR} \times (V_{O(MAX)} / V_O)$. Good choices for this components include the US1J (1 A) and UF5402 (3 A).

When the internal power MOSFET turns off, leakage inductance induces a voltage spike on the drain. To limit this voltage to below the 725 V BV_{DSS} rating of the internal MOSFET a clamp is required across the primary of the transformer. The clamp both limits the drain voltage and dissipates the leakage inductance energy. Clamp selection and design is similar to that of a standard flyback converter however the absence of bulk storage capacitance after the rectifier (to give high power factor) requires additional consideration.

The peak voltage on the drain is a function of the value of the input voltage, V_{OR} and the clamp voltage.

During each AC half-cycle, the primary peak current varies to provide an envelope that follows the AC voltage (giving high power factor). As the leakage energy is a function of the peak primary current this also varies during each AC half-cycle ($E_{LEAK} = 0.5 \times L_{LEAK} \times I_P^2$). Peak leakage energy occurs at the peak of the rectified input AC corresponding to the design spreadsheet value of I_P and it is at this point where the maximum peak drain voltage occurs.

The clamp must therefore be designed to provide sufficient drain voltage margin at the peak of the maximum AC input voltage ($1.41 \times VAC_{MAX}$) and the maximum output voltage. In addition the clamp voltage must also remain significantly above the value of V_{OR} to minimize the amount of magnetizing energy (the energy that is stored in the transformer during the switch on time) being dissipated in the clamp.

The Zener or Zener Bleed configurations are preferred for high efficiency because the clamp voltage does not reduce below a fixed value (defined by the voltage of the Zener) irrespective of the value of E_{LEAK} . In comparison an RCD clamp used in this design, least expensive clamp has a clamping voltage that varies with the value of E_{LEAK} , reducing with the value of E_{LEAK} . As the clamp voltage reduces, towards the value of V_{OR} , proportionally more energy is dissipated in the clamp and less is delivered to the output thereby reducing efficiency.

The Zener configuration (Figure 18a) is the simplest to design, gives the highest efficiency across variations in output voltage and requires the fewest components but may have higher EMI generation due to higher dv/dt and di/dt .

The Zener Bleed configuration provides the lower EMI generation of an RCD clamp but has a defined minimum clamp voltage. The operation is similar to the RCD clamp. When the primary

switch turns off, the leakage inductance energy charges C_{CLAMP} to above the voltage rating of VR_{CLAMP} . For the remainder of the switching period C_{CLAMP} is discharged via R_{CLAMP} and VR_{CLAMP} ready for the next turn-off event. The addition of VR_{CLAMP} in series with R_{CLAMP} ensures that the voltage across C_{CLAMP} cannot discharge to below the voltage rating of VR_{CLAMP} . Dissipation is shared between VR_{CLAMP} and R_{CLAMP} with the recommended voltage rating of VR_{CLAMP} being $\sim 10\%$ higher than the V_{OR} of the design.

The RCD configuration (Figure 18c with VR_{CLAMP} omitted) is attractive because of low EMI generation, low-cost and scalability for higher power designs. The higher dissipation may be accommodated by sizing the power rating of R_{CLAMP} or using multiple resistors in parallel. However the RCD clamp requires more careful design as the clamping voltage varies with output voltage and peak drain current. This requires that the maximum clamp voltage is set at $V_{O(MAX)}$ and therefore results in lower efficiency at the nominal output voltage (V_O).

By adding a Zener to the RCD configuration (Figure 18c with VR_{CLAMP} present) to form the RCD+Z provides a good compromise between the fixed clamping voltage of a Zener and high power capability of the RCD. The Zener provides a fixed voltage clamp during transients (start-up or output short-circuit) but during normal operation the RC network clamps the peak drain voltage.

Zener diode peak current for configuration 16a and 16b is typically 0.6 to $0.8 \times I_p$ and therefore transient suppressor diodes (TVS) are recommended. The P4KExxxA (1 W), P6KExxxA (5 W) and 1.5KExxxA (6.5 W) are good examples (where xxx represents the voltage rating and A indicates uni-directional).

For the RCD+Z and Zener Bleed configurations (Figures 16c and 16d) the peak Zener currents are significantly lower and standard 1-2 W Zener diode may be selected such as the BZY97Cxxx.

For high-power capability multiple Zener diodes may be placed in series (as shown in Figure 18b) with the overall voltage being equal to the desired clamping voltage. This is typically only required in output powers above 50 W based on Zener temperature rise.

For Figure 18 configurations (a), (b) and (c) a voltage rating of 200 V is recommended for VR_{CLAMP} but this can be lowered to provide additional drain voltage margin providing the value of VR_{CLAMP} is $>1.4 \times V_{OR(MAX)}$, where $V_{OR(MAX)}$ is equal to $V_{OR} \times (V_{O(MAX)} / V_O)$.

Select the power rating of the clamp Zener(s) and/or resistor(s) based on the value for P_{CLAMP} given in the Key Design Parameters section of the design spreadsheet. This value represents the average energy dissipated in the clamp over one AC line cycle. Table 4 provides a good starting point for component selection based on output power.

Once a prototype is constructed verify the clamp component temperature to ensure that there is sufficient design margin

when operated inside the final product enclosure (including LED) and highest ambient temperature.

D_{CLAMP} should be a fast or ultrafast type with a reverse recovery time <500 ns. Under no circumstances should a standard recovery rectifier diode be used. The high dissipation that may result during start-up or an output short-circuit can cause failure of the diode.

Step 8 – Output Overvoltage (Disconnected Load Protection – Optional) (D8, C15, R22, R27, VR4, C14 and Q2 in Figure 1)

The purpose of this optional functional block is to limit the output voltage should the load (LED string) be disconnected. Without this protection the output voltage will rise to a high value that can cause failure of the output capacitors, the clamp components and the LYTSwitch-4 device. Even in LED retro-fit lamp applications, where disconnection of the LED load is a fault condition and represents product failure, output OVP may still be desirable to protect the supply during the manufacturing process and maintain the output voltage within SELV (safety extra low voltage) safety limits.

During unloaded operation the output voltage will rise, resulting in a proportional rise in the bias winding voltage. Once VR4 conducts and Q2 is biased on the FEEDBACK pin of U1 is pulled to source, initiating auto-restart mode. Once in auto-restart the 300 ms (600 ms – High-Line Family) off-time allows the output voltage to discharge via R23.

As soon as the load is reconnected normal operation resumes after the completion of the auto-restart off period. The bias voltage is separately rectified and filtered by D8 and C15 to allow a faster response time than using the voltage across C9. Diode D8 can be any small signal diode with a voltage rating greater than the value given in the design spreadsheet (PIV_B) and a current rating >150 mA. The value of C15 is not critical, use a 100 nF - 1 μ F value and voltage rating above the bias voltage if no better data is available. Resistor R22 provides some load across C14 preventing peak charging. Start with a value of 1 k Ω , 5%.

Select the initial voltage rating of VR4 to be $V_{OVP} \times N_B/N_S + 5$ V where the value of V_{OVP} is given in the Applications Variables section of the design spreadsheet. The 5 V figure compensates for the effects of peak charging and prevents false triggering under normal operation. Parts with power ratings ≤ 0.5 W and a tolerance of 5% are recommended.

Capacitor C14 provides noise filtering. Select any generic 100 nF, 50 V ceramic capacitor. Resistor R22 defines the current before Q2 is biased on, improving accuracy by operating the Zener closer to its data sheet test current. A value of 330 Ω to 1 k Ω , 5% is recommended, giving a Zener current of 0.5 mA to 2 mA. Transistor Q2 can be any small signal NPN transistor (collector voltage is <10 V and currents <1 mA). Once a prototype is constructed adjust the voltage of VR4 to be 5 – 10 V above the measured voltage across C15 at $V_{O(MAX)}$ (the maximum LED string voltage). This ensures that Q2 remains

completely off during normal operation, preventing changing the output current.

Step 9 – Output Diode, Capacitors and Pre-load

(D7, C11, C12 and R23)

Select an output diode with a current rating of $\geq I_O$ and a voltage rating $V_{RRM} > PIV_S$ where I_O and PIV_S are values from the design spreadsheet. A current rating of $\geq 2 \times I_O$ results in higher efficiency and should be considered where necessary.

Ultrafast ($t_{RR} < 150$ ns) or Schottky types should be selected. Schottky types will give higher efficiency, especially in lower output voltage designs where the diode forward voltage is a larger proportion of the secondary winding voltage.

Low or very low ESR capacitors should be used. Select the values based on allowable output (LED) current ripple with an initial value = ~ 1.5 μ F per mA of output current for $\pm 50\%$ output current ripple. The capacitance value may be split across several capacitors for space reasons. When using low ESR types the ripple current rating of the capacitors is typically much higher than actual ripple current so typically this rating doesn't need to be considered.

Larger values of output capacitance reduces the output ripple and improves dimming range by maintaining feedback into the LYTSwitch-4 device even at very small TRIAC conduction angles.

Output LED ripple currents of $\leq 50\%$ vs. DC have little performance impact, with negligible change in LED efficiency or color temperature.

Either electrolytic or ceramic capacitors may be used. Ceramic capacitors offer longer lifetime than electrolytic types however when used as output capacitors there is less benefit. This is due to the effect on LED operation at end life. Here the reduction in capacitance and increase in ESR results in higher LED ripple current but not outright failure of the driver. Lifetime of electrolytic capacitors is directly affected by operating temperature. However when using low ESR types with sufficient capacitance to limit output current ripple to $\leq 50\%$ then capacitor self-heating is negligible and the operating temperature is equal to the ambient temperature.

Select the value of the output discharge and pre-load resistor to provide a current of 1.5 mA at the output voltage ($R15 = V_O / 1.5$ mA).

This resistor causes the output to discharge below the LED string voltage when the AC is removed and therefore ensures the LED extinguish rather than there being a slight glow for several seconds after AC is removed.

Step 10 – TRIAC Leading Edge Dimmer Compatibility Components

Working with TRIAC Dimmers

The requirement to provide output dimming with low-cost, TRIAC based, leading edge phase dimmers introduces a number of trade-offs in the design.

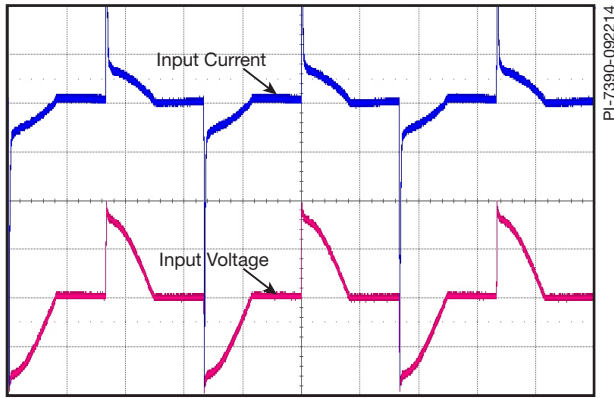

Figure 19. Typical Input Voltage and Current Waveforms for a Leading Edge TRIAC Dimmer Connected to a Driver at 90° Conduction Angle. Upper: AC Current (200 mA / div.), Lower: AC Voltage (200 V / div.)

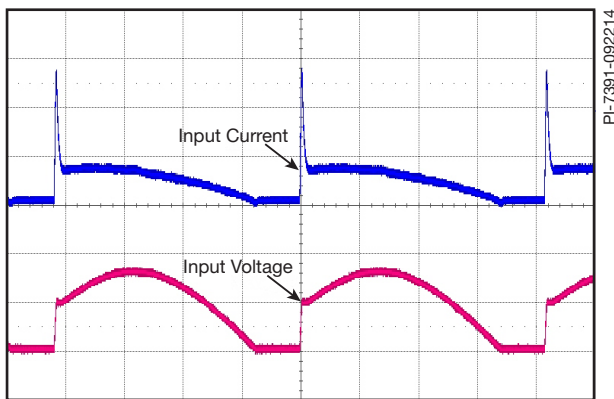

Figure 20. Resultant Waveforms Following Rectification of Typical TRIAC Dimmer Output. Upper: Rectified AC Current (200 mA / div.), Lower: Rectified AC Voltage (200 V / div.)

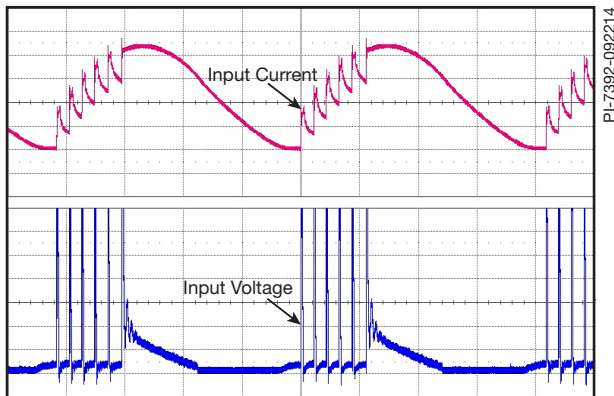

Figure 21. Example of Phase Angle Dimmer Showing Erratic Firing Following Rectification of Typical TRIAC Dimmer Output. Upper: Rectified AC Voltage (100 V / div.), Lower: Rectified AC Current (0.3 A / div.)

For correct operation incandescent phase angle dimmers typically have a specified minimum load, typically ~40 W for a 230 VAC rated unit. This is to ensure that the current through the internal TRIAC stays above its specified holding current threshold.

Due to the much lower power consumed by LED lighting the input current drawn by the lamp is below the holding current of the TRIAC within the dimmer. The input capacitance of the

driver allows large inrush currents to flow when the TRIAC fires. This then generates input current ringing with the input stage and line inductance which may cause the current to fall below the TRIAC holding current. Both of these mechanisms cause undesirable behavior such as limited dimming range and/or flickering.

To overcome these issues two circuit blocks, damper and bleeder, are incorporated in dimming applications. The drawback of these circuits is increased dissipation and therefore reduced efficiency of the supply.

Figure 19 shows the line voltage and current at the input of a leading edge TRIAC dimmer. In this example, the TRIAC conducts at 90 degrees.

Figure 20 shows the desired rectified bus voltage and current. Figure 21 shows undesired rectified bus voltage and current with the TRIAC turning off prematurely and restarting. This is due to the input current ringing below the holding current of the TRIAC, excited by the initial inrush current.

If the TRIAC is turning off before the end of the half cycle or rapidly turning on and off then a bleeder and damper circuit are required.

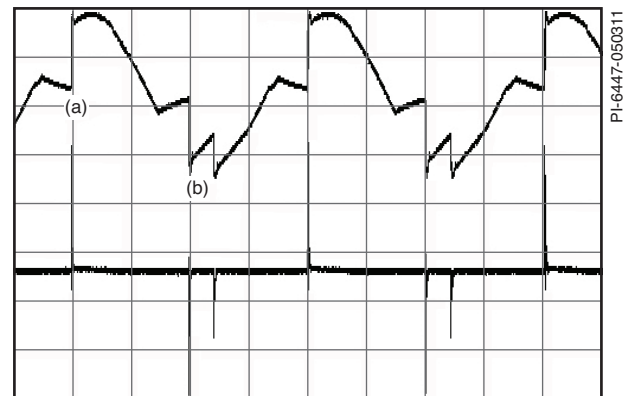

Figure 22. Example of TRIAC Dimmer Output Voltage and Current Showing Half-Cycle Dissymmetry Upper: AC Voltage (200 V / div.), Lower: AC Current (1 A / div.)

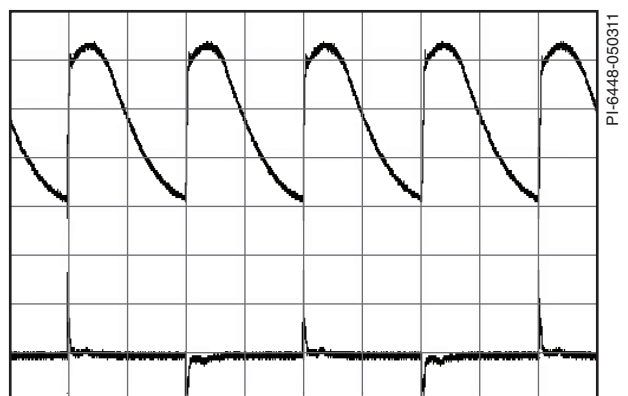

Figure 23. Example Waveforms Showing Correct TRIAC Operation at Minimum Conduction Angle. Upper: Rectified AC Voltage (100 V / div.), Lower: AC Current (1 A / div.)

In general as power dissipated in the bleeder and damper circuits increases, so does dimmer compatibility.

Initially install a bleeder network across the rectified power bus (R1 and C1 in Figure 1) with initial values of 0.22 μ F and a total resistance of 510 Ω and power rating of 2 W.

Reduce the capacitance value to find the minimum acceptable value. Reducing the capacitance value reduces power dissipation and therefore increases efficiency.

If the bleeder circuit does not maintain conduction in the TRIAC on both AC half-cycles, then add a damper. Figure 22 shows a typical waveform where the bleeder circuit alone is not sufficient to maintain correct TRIAC conduction on both AC half-cycles. On positive half-cycles (a) the TRIAC conducts for the full conduction angle but on the negative half-cycle (b) the TRIAC fires twice. In this case a damper is required. The purpose of the damper is to limit the inrush current that flows through the input stage and line inductances as the input capacitance charges. Without limiting this current the input capacitor (C2 in Figure 1) voltage can reach significantly above the peak of the incoming AC voltage which causes the TRIAC current to fall to zero and therefore turn off. This cycle then repeats causing flicker.

For designs with an output power of less than 6 W, a passive damper may be used. Here a simple resistor in series with the AC input. Values in the range of 10 Ω – 150 Ω are typical with the upper range being limited by the allowed dissipation / temperature rise and reduction in efficiency. Values below 10 Ω may also be used but are less effective especially in high AC line input designs.

For higher power designs or if the passive damper is insufficient to prevent incorrect TRIAC operation then an active damper is required. This is typical in high-line applications due to the much larger inrush current that flows when the TRIAC turns on. A low-cost active damper circuit is formed by R6, R29, R28, R8, D10, C3, VR5, Q3 and Q1 in Figure 1. Resistor R8 limits the inrush current and can be a much higher value for better damping than the passive case as they are in circuit for only a fraction of the line cycle. MOSFET Q1 shorts R8 after a delay defined by R16, R29 and C3. The delay is adjusted to give the shortest time that provides acceptable dimmer performance to minimize the dissipation in R8. Figure 23 shows the effect of adding the damper compared to the waveform in Figure 22. Here the TRIAC correctly conducts once each half-cycle. The MOSFET required is a low current, low-cost device available with very low gate current requirements. Maximum dissipation in the resistors of the damper and bleeder occurs at 90 degree TRIAC conduction and therefore thermal testing should be performed under this condition to verify component temperatures. For high-line designs it may be necessary to use a wire wound construction for the active damper resistor to prevent failure. This is due to the high instantaneous power dissipated when AC is first applied. In this case a single resistor is acceptable, for example the CRF series from Vitrohm.

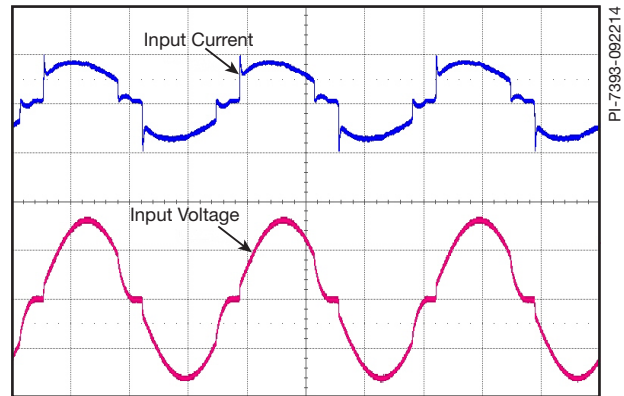

Figure 24. Typical Dimmer Output Voltage and Current Waveforms for a Trailing Edge Dimmer at Full Conduction Angle. Upper: AC Current (200 mA / div.), Lower: AC Voltage (200 V / div.)

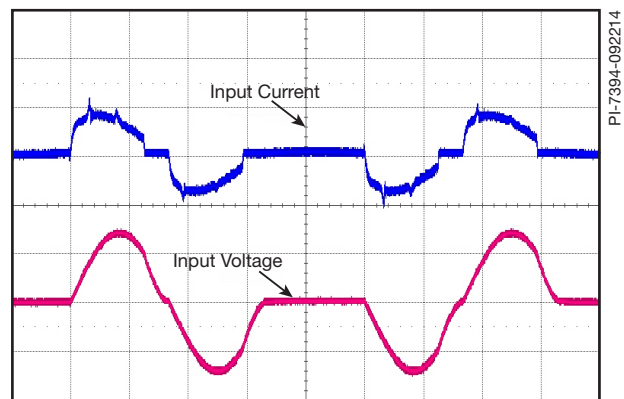

Figure 25. Trailing Edge Dimmer Example of Phase Angle Dimmer Showing Misfiring at Maximum Conduction Angle. Upper: AC Current (200 mA / div.), Lower: AC Voltage (200 V / div.)

Part Number	Supplier	Specification	LED Drive Power
STQ2NK60ZR	ST	0.4 A, 600 V, 8 Ω , TO-92	<14 W
IRFU320	VISHAY	3 A, 400 V, 1.8 Ω , TO-251	>15 W

Table 6. Example of MOSFETs Suitable for use in an Active Damper.

It's common for different dimmers to behave differently across manufacturers and power ratings. For example a 300 W dimmer requires less dampening and requires less power loss in the bleeder than a 600 W or 1000 W dimmer due to the use of a lower current rating TRIAC which typically have lower holding currents. Line impedance differences can also cause variation in behavior so during development the use of an AC source is recommended for consistency however testing using AC building power should also be performed.

Electronic Trailing Edge Dimmers

Figure 24 shows the line voltage and current at the input of the power supply with a trailing edge electronic dimmer. In this

example, the dimmer conducts at 90 degrees. This type of dimmer typically uses a power MOSFET or IGBT to provide the switching function and therefore no holding current is necessary. Also since the conduction begins at the zero crossing, high current surges and line ringing are not an issue. Use of these types of dimmers typically does not require damper circuit but bleeder circuit is necessary to provide supply path for internal control of the dimmer. Figure 25 shows the line voltage and current at the input of the power supply with a trailing edge electronic dimmer misfiring one half-cycle due to lack of bleeder current.

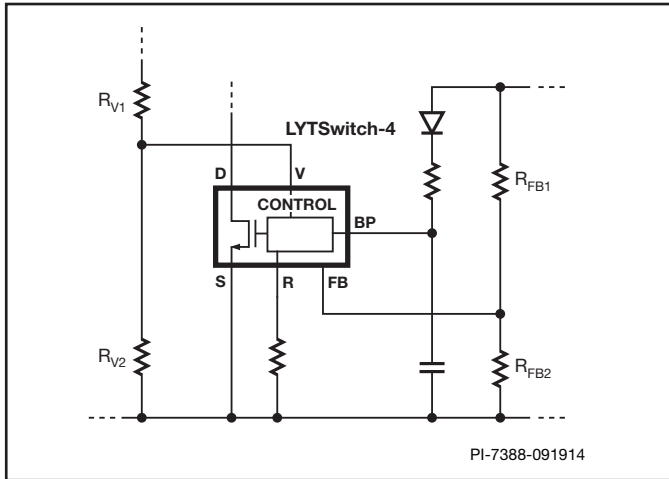

Figure 26. Partial Schematic Defining the Location of Resistors R_{V1} , R_{V2} , R_{FB1} and R_{FB2} used during Output Fine Tuning.

Step 11 – Fine Tuning

Once a prototype has been built it may be necessary to adjust the values of the VOLTAGE MONITOR and FEEDBACK pin resistors. This adjustment compensates for the actual bias voltage in operation (tracking between bias winding and secondary) the actual nominal output voltage (LED string voltage) and any voltage drops in the input stage. A two-step procedure is required as both the VOLTAGE MONITOR pin and feedback resistors change the output current. The VOLTAGE MONITOR pin resistors optimize line voltage regulation whereas the FEEDBACK pin resistors primarily center the output current. Typically two or three iterations are required.

Start by adjusting the VOLTAGE MONITOR pin resistor values before moving onto the FEEDBACK pin resistors. Figure 26 shows the location of both the VOLTAGE MONITOR pin and FEEDBACK pin resistors.

Enter the actual values of R_{V1} and R_{V2} (if fitted) into the VOLTAGE MONITOR pin Resistor Fine Tuning section of the design spreadsheet. If left blank then the original spreadsheet values are assumed. For non-dimming designs measure the output current at the nominal line voltages of the input specification e.g. 115 VAC or 230 VAC for a single input specification. For designs that will operate with phase angle TRIAC dimmers measure at the minimum and maximum input voltage of the specified single line input voltage range e.g. for 115 VAC nominal measure at 90 VAC and 132 VAC, for 230 VAC nominal measure at 195 VAC and 265 VAC.

FINE TUNING (Enter measured values from prototype)					
V pin Resistor Fine Tuning					
RV1		2.00	M-ohms		Upper V Pin Resistor Value
RV2		1.E+12	M-ohms		Lower V Pin Resistor Value
VAC1		115	V		Test Input Voltage Condition1
VAC2		230	V		Test Input Voltage Condition2
IO_VAC1		0.700	A		Measured Output Current at VAC1
IO_VAC2		0.700	A		Measured Output Current at VAC2
RV1 (new)		2.00	M-ohms		New RV1
RV2 (new)		10455.82	M-ohms		New RV2
V_OV		161.1	V		Typical AC input voltage at which OV shutdown will be triggered
V_UV		34.5	V		Typical AC input voltage beyond which power supply can startup
FB pin resistor Fine Tuning					
RFB1		133.33	k-ohms		Upper FB Pin Resistor Value
RFB2		1.E+12	k-ohms		Lower FB Pin Resistor Value
VB1		22.47	V		Test Bias Voltage Condition1
VB2		27.53	V		Test Bias Voltage Condition2
IO1		0.700	A		Measured Output Current at Vb1
IO2		0.700	A		Measured Output Current at Vb2
RFB1 (new)		133.3	k-ohms		New RFB1
RFB2(new)		1.E+12	k-ohms		New RFB2

Figure 27. Fine Tuning Section of the Design Spreadsheet.

Once entered the spreadsheet will provide new values ($R_{V1(NEW)}$, $R_{V2(NEW)}$). Values for $R_{V2(NEW)}$ above 10 M Ω can be ignored and $R_{V2(NEW)}$ omitted. As the new values will also modify the line overvoltage values these are shown for reference. Change the resistor values on the prototype and re-measure the output current and move to FEEDBACK pin resistor adjustment.

Enter the actual values of R_{FB1} and R_{FB2} (if fitted) into the FEEDBACK pin resistor Fine Tuning section of the design spreadsheet. If left blank then the original spreadsheet values are assumed.

For non-dimming designs measure the bias voltage and output current at the nominal line voltages of the input specification. For example for a single input voltage specification measure the bias voltage and output current at 115 VAC (V_{B1} , I_{O1}) for low-line or 230 VAC (V_{B2} , I_{O2}) for high-line. For designs that will operate with phase angle TRIAC dimmers measure at the minimum and maximum input voltage of the specified single line input range. For example a design with a nominal input voltage of 115 VAC should be measured at 85 VAC (V_{B1} , I_{O1}) and 132 VAC (V_{B2} , I_{O2}). Once these values have been entered the spreadsheet will calculate new values for the FEEDBACK pin resistors ($R_{FB1(NEW)}$, $R_{FB2(NEW)}$). Values for $R_{FB2} > 4$ M Ω can be ignored and R_{FB2} omitted.

Replace the existing resistors in the prototype with new values and measure the output current. If the output current is centered and line voltage regulation acceptable then no further adjustment is required. However if further improvement is desired complete an additional iteration, entering the updated values for R_{FB1} , R_{FB2} , R_{V1} and R_{V2} into the relevant cells in the Fine Tuning section of the spreadsheet.

Tips and Tricks

Accurately Measuring Output Power

When measuring the efficiency of a LYTSwitch-4 design it is critical to accurately measure the output power. The normal practice of using a digital multimeter to measure the output current and voltage can cause significant errors if the line frequency output ripple is significant. For example a design with 100% output ripple compared to a design of the same output power but 10% ripple measured with DVMs will result in an efficiency measurement error of -3%. To avoid the error in design with output current ripple $> \sim 30\%$ either use a power meter to directly measure the output power (for example the Yokogawa WT2xx series measures accurately to DC) or temporarily connect a large additional output capacitance during measurement (2200 μ F). Once the output current and voltage are close to a DC level the measurement error when using DVMs becomes negligible.

PWM Dimming

Figure 29 shows a circuit configuration for implementing PWM dimming which converts the digital signal into an analog current which adjusts the FEEDBACK (FB) pin current and therefore the output current. The dimming range achievable is 16:1.

The PWM signal is injected via Q1. This may be either a small signal NPN transistor or for isolation the transistor side of an optocoupler. With no PWM signal the value of I_{FB} (the current into the FEEDBACK pin) is unchanged and the output is regulated as normal. As the PWM signal duty cycle increases the current into the FEEDBACK pin is lowered, lowering output current. At 100% duty cycle the FEEDBACK pin current is at a minimum giving the lowest output current.

With the value as shown R4 provides a bias from the BYPASS pin into the FEEDBACK pin which prevents the FEEDBACK pin current falling below the auto-restart threshold current of 20 μ A when Q1 is fed with a 100% duty cycle signal. This will also disable auto-restart during a fault condition such as output short-circuits. This can be avoided if the maximum PWM duty cycle is limited or the value of R2 is adjusted to limit the maximum current through the optocoupler such that I_{FB} is always > 10 μ A.

The value for R_{FB} provided by the PIXIs design spreadsheet is split between R1 and R3 but must be increased to account for the 10 μ A provided via R4. The expression for R1 is shown in the Figure. The value of R3 is not critical but should be a 1% type to give output current matching unit to unit.

The calculation for R2 is designed to limit the minimum voltage at the output of the resistor divider formed by R2 and R3 to be equal to 2.5 V when the PWM signal duty cycle is 100% duty cycle. For this example R2 would be 11 k.

The value of C1 is selected such that the time constant formed by C1 and R2 is > 5 times the period of the PWM signal.

PWM frequencies above the eye's response (> 100 Hz) are recommended to greatly reduce the likelihood of perceiving shimmer in the output.

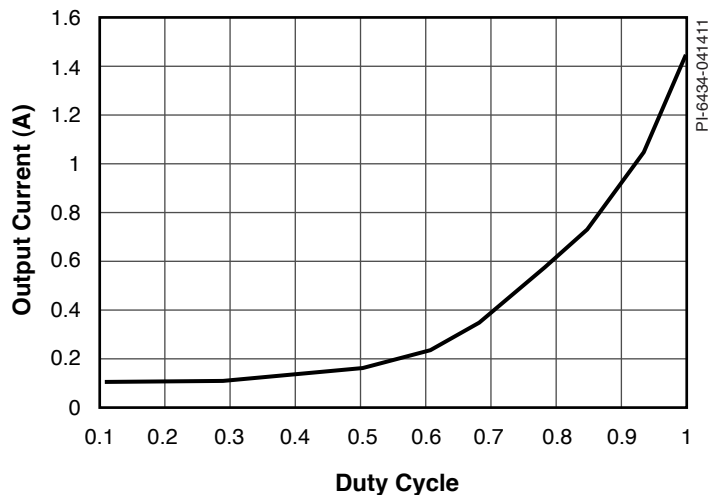

Figure 28. Duty Cycle to Output Current Characteristic for the PWM Dimming Circuit Shown in Figure 29.

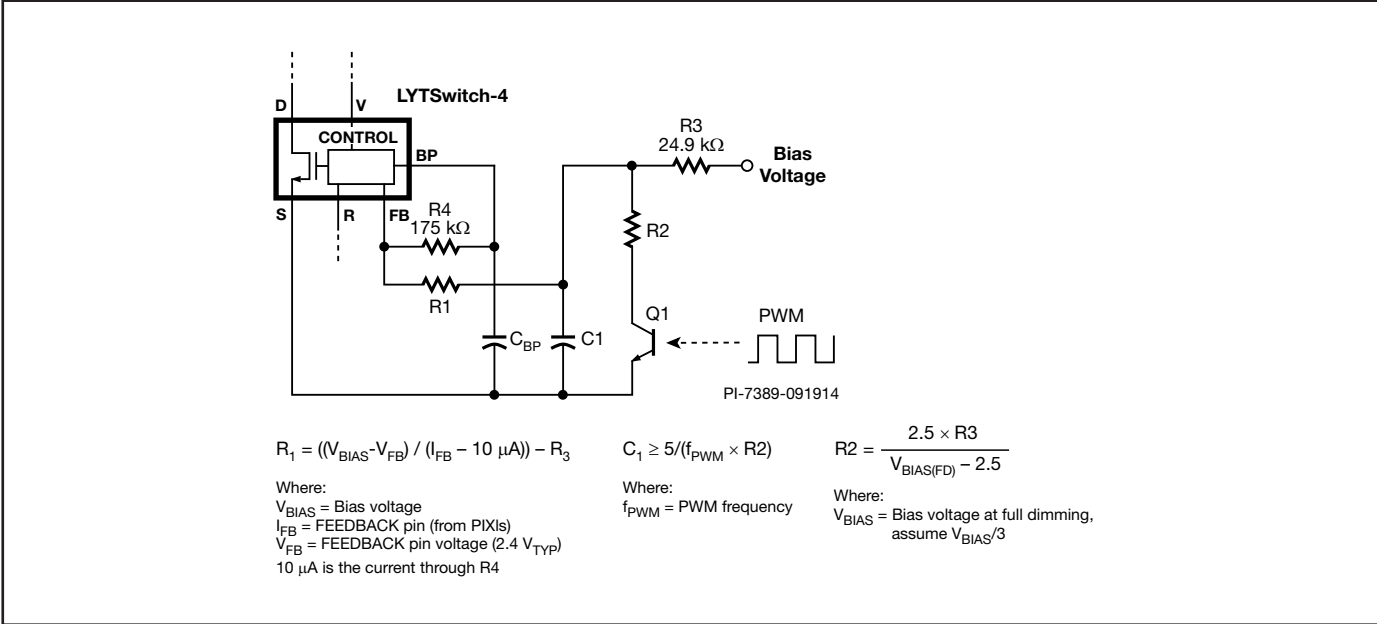

Figure 29. Circuit Configuration for PWM Dimming.

Revision	Notes	Date
A	Initial Release	12/14

For the latest updates, visit our website: www.power.com

Power Integrations reserves the right to make changes to its products at any time to improve reliability or manufacturability. Power Integrations does not assume any liability arising from the use of any device or circuit described herein. POWER INTEGRATIONS MAKES NO WARRANTY HEREIN AND SPECIFICALLY DISCLAIMS ALL WARRANTIES INCLUDING, WITHOUT LIMITATION, THE IMPLIED WARRANTIES OF MERCHANTABILITY, FITNESS FOR A PARTICULAR PURPOSE, AND NON-INFRINGEMENT OF THIRD PARTY RIGHTS.

Patent Information

The products and applications illustrated herein (including transformer construction and circuits external to the products) may be covered by one or more U.S. and foreign patents, or potentially by pending U.S. and foreign patent applications assigned to Power Integrations. A complete list of Power Integrations patents may be found at www.power.com. Power Integrations grants its customers a license under certain patent rights as set forth at <http://www.power.com/ip.htm>.

Life Support Policy

POWER INTEGRATIONS PRODUCTS ARE NOT AUTHORIZED FOR USE AS CRITICAL COMPONENTS IN LIFE SUPPORT DEVICES OR SYSTEMS WITHOUT THE EXPRESS WRITTEN APPROVAL OF THE PRESIDENT OF POWER INTEGRATIONS. As used herein:

1. A Life support device or system is one which, (i) is intended for surgical implant into the body, or (ii) supports or sustains life, and (iii) whose failure to perform, when properly used in accordance with instructions for use, can be reasonably expected to result in significant injury or death to the user.
2. A critical component is any component of a life support device or system whose failure to perform can be reasonably expected to cause the failure of the life support device or system, or to affect its safety or effectiveness.

The PI logo, TOPSwitch, TinySwitch, LinkSwitch, LYTSwitch, InnoSwitch, DPA-Switch, PeakSwitch, CAPZero, SENZero, LinkZero, HiperPFS, HiperTFS, HiperLCS, Qspeed, EcoSmart, Clampless, E-Shield, Filterfuse, FluxLink, StakFET, PI Expert and PI FACTS are trademarks of Power Integrations, Inc. Other trademarks are property of their respective companies. ©2014, Power Integrations, Inc.

Power Integrations Worldwide Sales Support Locations

World Headquarters

5245 Hellyer Avenue
San Jose, CA 95138, USA.
Main: +1-408-414-9200
Customer Service:
Phone: +1-408-414-9665
Fax: +1-408-414-9765
e-mail: usasales@powerint.com

China (Shanghai)

Rm 2410, Charity Plaza, No. 88
North Caoxi Road
Shanghai, PRC 200030
Phone: +86-21-6354-6323
Fax: +86-21-6354-6325
e-mail: chinasales@powerint.com

China (Shenzhen)

17/F, Hivac Building, No. 2, Keji
Nan 8th Road, Nanshan District,
Shenzhen, China, 518057
Phone: +86-755-8672-8689
Fax: +86-755-8672-8690
e-mail: chinasales@powerint.com

Germany

Lindwurmstrasse 114
80337 Munich
Germany
Phone: +49-895-527-39110
Fax: +49-895-527-39200
e-mail: eurosales@powerint.com

India

#1, 14th Main Road
Vasanthanagar
Bangalore-560052 India
Phone: +91-80-4113-8020
Fax: +91-80-4113-8023
e-mail: indiasales@powerint.com

Italy

Via Milanese 20, 3rd. Fl.
20099 Sesto San Giovanni (MI)
Italy
Phone: +39-024-550-8701
Fax: +39-028-928-6009
e-mail: eurosales@powerint.com

Japan

Kosei Dai-3 Bldg.
2-12-11, Shin-Yokohama,
Kohoku-ku
Yokohama-shi Kanagawan
222-0033 Japan
Phone: +81-45-471-1021
Fax: +81-45-471-3717
e-mail: japansales@powerint.com

Korea

RM 602, 6FL
Korea City Air Terminal B/D, 159-6
Samsung-Dong, Kangnam-Gu,
Seoul, 135-728, Korea
Phone: +82-2-2016-6610
Fax: +82-2-2016-6630
e-mail: koreasales@powerint.com

Singapore

51 Newton Road
#19-01/05 Goldhill Plaza
Singapore, 308900
Phone: +65-6358-2160
Fax: +65-6358-2015
e-mail: singaporesales@powerint.com

Taiwan

5F, No. 318, Nei Hu Rd., Sec. 1
Nei Hu Dist.
Taipei 11493, Taiwan R.O.C.
Phone: +886-2-2659-4570
Fax: +886-2-2659-4550
e-mail: taiwansales@powerint.com

UK

First Floor, Unit 15, Meadway
Court, Rutherford Close,
Stevenage, Herts. SG1 2EF
United Kingdom
Phone: +44 (0) 1252-730-141
Fax: +44 (0) 1252-727-689
e-mail: eurosales@powerint.com

Applications Hotline

World Wide +1-408-414-9660

Applications Fax

World Wide +1-408-414-9760