

▼ Electrical Diagram

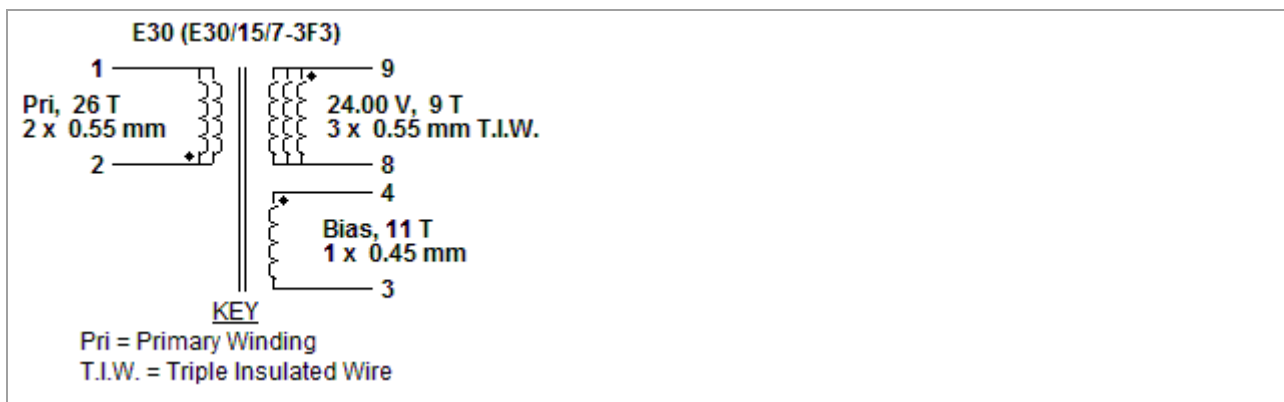

▼ Mechanical Diagram

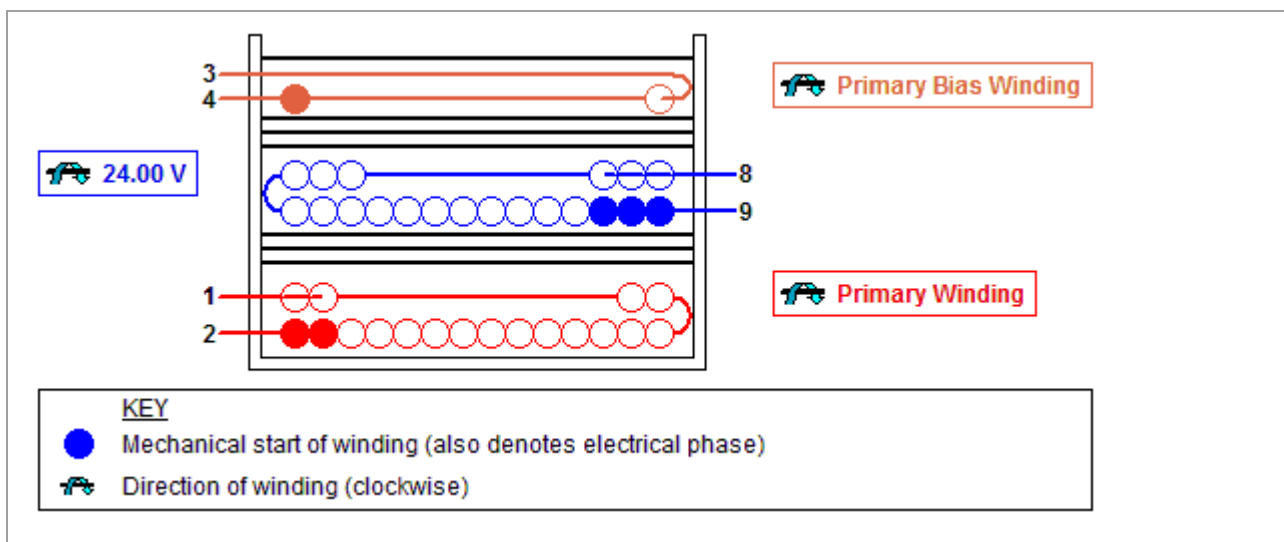

▼ Winding Instruction

Primary Winding

Start on pin(s) 2 and wind 26 turns (x 2 filar) of item [5], in 2 layer(s) from left to right. Winding direction is clockwise. At the end of 1st layer, continue to wind the next layer from right to left. On the final layer, spread the winding evenly across entire bobbin. Finish this winding on pin(s) 1.

Add 3 layers of tape, item [3], for insulation.

Secondary Winding

Start on pin(s) 9 and wind 9 turns (x 3 filar) of item [6]. Spread the winding evenly across entire bobbin. Winding direction is clockwise. Finish this winding on pin(s) 8.

Add 3 layers of tape, item [3], for insulation.

Primary Bias Winding

Start on pin(s) 4 and wind 11 turns (x 1 filar) of item [7]. Winding direction is clockwise. Spread the winding evenly across entire bobbin. Finish this winding on pin(s) 3.

Add 1 layer of tape, item [3], for insulation.
Core Assembly
Assemble and secure core halves. Item [1].
Varnish
Dip varnish uniformly in item [4]. Do not vacuum impregnate.

▼ Comments

1. For non margin wound transformers use triple insulated wire for all secondary windings.
--

▼ Materials

Item	Description
[1]	Core: E30 (E30/15/7-3F3), 3F3, gapped for ALG of 129 nH/T ²
[2]	Bobbin: Generic, 7 pri. + 7 sec.
[3]	Barrier Tape: Polyester film [1 mil (25 µm) base thickness], 17.50 mm wide
[4]	Varnish
[5]	Magnet Wire: 0.55 mm, Solderable Double Coated
[6]	Triple Insulated Wire: 0.55 mm
[7]	Magnet Wire: 0.45 mm, Solderable Double Coated

▼ Electrical Test Specifications

Parameter	Condition	Spec
Electrical Strength, VAC	60 Hz 1 second, from pins 1,2,3,4 to pins 8,9.	3000
Nominal Primary Inductance, µH	Measured at 1 V pk-pk, typical switching frequency, between pin 1 to pin 2, with all other Windings open.	90
Tolerance, ±%	Tolerance of Primary Inductance	10.0
Maximum Primary Leakage, µH	Measured between Pin 1 to Pin 2, with all other Windings shorted.	2.70

Although the design of the software considered safety guidelines, it is the user's responsibility to ensure that the user's power supply design meets all applicable safety requirements of user's product.