

SCALE™-2+ IGBT Gate Driver Core 2SD300C17

- Switching frequency up to 60 kHz
- ±30 A peak output gate current
- ±15 V gate voltage
- 15 V logic level interface
- 2 x 4 W output power
- Direct and half-bridge modes
- IGBT short-circuit protection

Dual-Channel Gate Driver Core for Blocking Voltages up to 1700 V

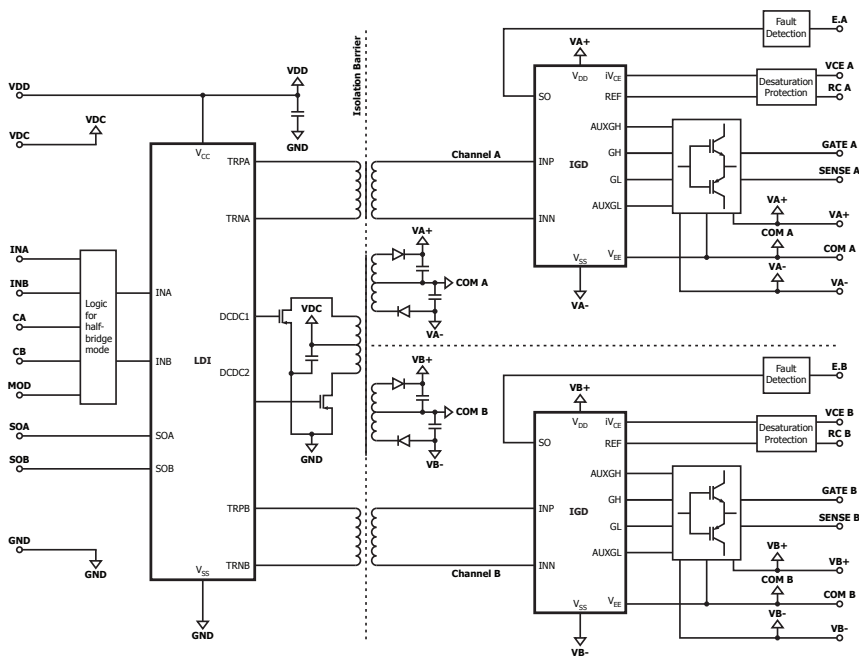

PI-8682-041218

Applications

- Railway main and auxiliary inverters
- Photovoltaic inverters
- Wind power inverters
- Medium-voltage drives
- Industrial motor drives

Certifications

- Reinforced isolation according to IEC 60664-1

Product Details

Parameter	Min	Typical	Max	Unit
Nominal supply voltage		15		V
Supply current @ $f_{IN} = 0$ Hz		79		mA
Supply current @ $f_{IN} = 60$ Hz			540	mA
Output power			3	W
Gate voltage		+15 / -15		V
Peak output current (gate current)	-30		+30	A
Switching frequency (f_s) ¹			60	kHz
Duty cycle	0		100	%
Turn-on delay		620		ns
Turn-off delay		480		ns
Operating temperature	-40		+85	°C

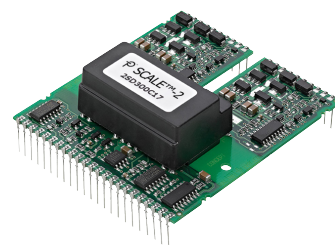

¹ Maximum switching frequency depends on the IGBT gate charge. See data sheet for actual value of specific driver.

Design Support

Available Products 2SD300C17 Products list (www.power.com/2SD300C17)